

EMPFÄNGER- SCHALTUNGEN

DER
RADIO-INDUSTRIE

BAND VIII

Siemens · Star · Staßfurt

Staudigl · Südfunk

TAK · Tefag · Tefi · TEKADE

EMPFÄNGER-SCHALTUNGEN DER RADIO-INDUSTRIE
BAND VIII



BÜCHER FÜR DEN RUNDFUNKTECHNIKER

EMPFÄNGER-
SCHALTUNGEN
DER
RADIO-INDUSTRIE

BAND VIII

Zusammengestellt von Ing. Heinz Lange
und Ing. Heinz K. Nowisch

Vierte Auflage



FACHBUCHVERLAG LEIPZIG 1957

S. 69

S. 97

S.05

621.396.62



8836/8



126438

Redaktionsschluß 31. 7. 56

Alle Rechte vorbehalten · Fachbuchverlag Leipzig

Satz und Druck: (IV/26/14) Tribüne, Verlag und Druckereien des FDGB

Druckerei II, Naumburg (Saale)

Veröffentlicht unter der Lizenznummer 114-210/340/56 des Ministeriums für Kultur

der Deutschen Demokratischen Republik, Hauptverwaltung Verlagswesen

D 126438

VORWORT

Dieses Buch setzt als VIII. Band die Schaltbildersammlung fort, in der 30 Jahre rastloser Arbeit deutscher Fachleute ihren Niederschlag finden. Es ist gelungen, ein Standardwerk zusammenzustellen, das für die gesamte Radiotechnik von unschätzbarem Wert ist.

Angefangen vom Audionempfänger aus dem Jahre 1924 bis zu den höchstentwickelten Spitzengeräten, deren Produktion durch den zweiten Weltkrieg unterbrochen wurde, und wieder beginnend mit den ersten primitiven Nachkriegsgeräten bis zu den letzten Konstruktionen sind die Schaltungen, nach Firmen und Typen geordnet, in dem Gesamtwerk zu finden.

Mit dieser Schaltungssammlung wollen wir dazu beitragen, die Instandsetzung von Rundfunkgeräten wesentlich zu erleichtern und damit einem dringenden Bedürfnis der Reparaturwerkstätten entsprechen — das alles mit dem Ziel, für recht viele schaffende Menschen den Empfang unserer Rundfunksendungen zu vervollkommen. Darüber hinaus gibt diese Sammlung unserem Nachwuchs in der Werkstatt, den Studierenden der Elektrotechnik und den Entwicklungsingenieuren einen umfassenden Überblick über die Vielfalt und den Ideenreichtum der Schalttechnik.

Eine Bitte richten wir an alle, in deren Hände diese Sammlung gelangt: Sollten Sie noch im Besitz von Schaltungsunterlagen sein, die in dieser Sammlung nicht enthalten sind, so überlassen Sie uns diese für eine kurze Zeit. Damit würden Sie zum Nutzen der gesamten Radiotechnik zur Vervollständigung der Sammlung beitragen.

Allen Industriebetrieben, durch deren Mitarbeit dieses Werk entstehen konnte, sprechen wir hiermit unseren Dank aus.

Verfasser und Verlag

Leipzig, im Sommer 1956

INHALTSVERZEICHNIS

Siemens (Produktion nach 1945)

SH 1115 W Spitzensuper 52 . . .	14
SH 906 W Spitzensuper 51 . . .	16
SH 816 W Phonosuper 52 . . .	18
SH 814 W Großsuper 52 . . .	19
SH 813 W Qualitätssuper 52 . . .	20
SH 712 W Exportsuper 52 . . .	21
SB 780 W Schatulle . . .	22
SH 705 W Großsuper 51 . . .	24
SB 700 W siehe SB 780 W	
SK 699 W Hansa III . . .	25
SH 696 W u. GW Qualitätssuper 50	26
SH 607 W Qualitätssuper 51 . . .	27
SH 607 GW Qualitätssuper 51 . . .	28
SB 603 AB Autosuper 52 . . .	29
SB 601 AB Autosuper 51 . . .	30
SH 598 W Symphonie . . .	31
SH 597 AB Autosuper . . .	32
SK 576 W Hansa . . .	33
S 522 siehe S 52 WR	
S 521 WR . . .	34
SH 511 W Spezialsuper 52 . . .	35
SH 511 GW u. GW/M Spezialsup. 52	36
SB 502 W Spezialsuper 51 . . .	37
SB 502 GW Spezialsuper 51 . . .	38
SK 495 GW Hansa II . . .	39
SB 490 GW siehe SB 481 GW	
SB 481 GW . . .	40
SB 480 GW . . .	41
SH 479W Melodie II siehe SH 598W	
SH 478 WF Melodie . . .	42
SH 477 GW Melodie . . .	43
SK 475 W Standard-Super . . .	44
SB 470 GW . . .	45
SK 468 W . . .	46
SH 467 W . . .	47
SB 460 GW . . .	48
SB 392 GWK . . .	49
SB 392 GWL . . .	50

SB 391 GWL . . .	51
SB 390 GWK . . .	52
SB 380 GW . . .	53
SB 380 GWL . . .	54
SH 287 GW Novalette . . .	55
SB 260 GW . . .	56
S 231 GW . . .	57
S 52 WR . . .	58
U 4 Wt u. U 4 GWt (UKW-Einsatz) . . .	59
U 2 W u. U 2 GW (UKW-Einsatz)	60
RM 1 Musiktisch . . .	61
TM 1 Musiktische siehe SH 598 W	
Kleinempfänger . . .	62
Kleinempfänger SKEK . . .	63
Marlofstein . . .	64
Marlofstein 3 . . .	65
Standard-Super . . .	66
UKW-Antennenumsatzer SAV 306 W . . .	67

Siemens (Produktion vor 1945)

Kammermusikgerät I . . .	71
Kammermusikgerät II . . .	72
Kammermusikgerät III . . .	73
Kammermusikgerät IV (Serie A)	74
Kammermusikgerät IV (Serie B)	76
Standard 3 Röhren GW . . .	78
Standard 3 Röhren W . . .	79
823 W siehe 73 W	
813 B . . .	80
640 W . . .	81
640 GW . . .	82
545 W siehe Kammermusikgerät I	
540 WL (Großsuper-Schatulle) . . .	83
540 CW (Großsuper-Schatulle) . . .	84
520 WL . . .	85
520 GWL . . .	86

P 141 W/604	87	54 W	130
120 GW	88	54 WLK Schatulle	131
95 W	89	54 GLK Schatulle	132
94 W	90	53 WL Schatulle	133
94 GW	91	53 GWL Schatulle	134
93 WK	92	52 WLK Luxus	135
93 GWK	93	52 W/134 siehe 50 W/134	
92 WK	94	52 GLK Luxus	136
92 GWK	95	51 W/134 siehe 50 W/134	
91 WLK	96	51 aG	137
91 GWK	97	51 bG	138
85 w	98	50 W/134	139
84 W Saturn	99	50 W/604	140
84 GW Saturn	100	48 WL	141
83 W Jupiter	101	48 WLK	142
83 GW Jupiter	102	48 GL	143
82 W Mars	103	48 GLK	144
82 GW Mars	104	47 W/WL/1234	145
81 W Merkur	105	47 aWL	146
81 GW Merkur	106	47 GL	147
76 W Kammermusik-Schatulle	107	46 W/WL	148
75 W Standard	108	46 G/GL	149
75 GW Standard	109	45 W	150
74 W Standard	110	41 W/604	151
74 GW Standard	111	41 W/134	152
73 W Standard	112	40 W 134/604	153
73 B	113	40 W	154
72 W Standard	114	DF 40 Drahtfunk	155
72 GW Standard	115	Rfe 39 siehe 50 W/134	
64 W Standard	116	Rfe 38 siehe 30 G	
64 GW Standard	117	37 WL	156
63 W Standard	118	37 WLK	157
63 GW Standard	119	37 GL/GLK	158
62 W Standard	120	36 WL	159
62 GW Standard	121	36 WLK und 36a WLK	160
57 WLK	122	36 GL	161
57 GLK	123	36 GLK	162
56 WL	124	35 W	163
56 WLK	125	Rfe 35	164
56 GL	126	34 G siehe 30 G	
56 GLK	127	Rfe 34 siehe 30 G	
55 WL	128	33 WL	165
55 GL	129	Rfe 33 siehe 40 W 134/604	

32 W	166
K 32 GWB	167
Rfe 32 siehe 40 W 134/604	
31 aW und bW	168
31 C/sG	169
31 aG und bG	170
Rfe 31 a/b siehe 50 W/604	
30 W	171
30 GW	172
30 G	173
Rfe 30 siehe 50 W/134	
Rfe 29	174
26 WLK	175
26 GLK	176
25 WL	177
25 WLK	178
25 GL	179
25 GLK	180
Rfe 24	181
23 W	182
23 G	183
23 GW	184
Rfe 23	185
22 W/aW	186
22 bW	187
22 G	188
22 GW	189
22 B siehe 20 B	
Rfe 22	190
21 W	191
21 G	192
Rfe 21 Protos	193
20 GW	194
20 B und 22 B	195
15 W	196
16 GW	198
14 W	199
14 GW	200
13 W	201
13 GW	202
12 GW	203
11 GW	204
5/4 Super-Schatulle W	205

Siemens italienische Produktion
siehe Telefunken unter gleicher
Geräte-Nummer

Siemens-Wechselrichter

SWR 1	208
SWR 2	209
SWR 3	210

Siemens-Verstärker

SMV 1 (Mikrofonvorverstärker)	213
SMV 1a (Mikrofonvorverstärker)	214
SV 1 W (Steuerverstärker)	215
SV 1/1 (Steuerverstärker)	216
Elaphon 1 und 2	217
Elaphon 1d	218
KV 2 W	219
SV 2aW (2-Watt-Verstärker)	220
Elaphon 2b	221
E verst 2b/1u.2b/2(25-Watt-Verst.)	222
Elaphon 3b	223
E verst 4a/1 (Mikrofonvorverst.)	224
KV 8 W	225
SV 8 aW (7,5-Watt-Verstärker)	226
SV 10 W	227
KV 10 G	228
Rfv 12 (Netzendstufe)	229
Rfv 12b (Netzendstufe)	230
KV 20 W (20-Watt-Verstärker)	231
SEV 20 W/2	232
SV 20/9 W (20-Watt-Verstärker)	233
SV 20/10 W (20-Watt-Verstärker)	234
SV 20 aW (20-Watt-Verstärker)	235
SV 20 bW (20-Watt-Verstärker)	236
SV 70 W (70-Watt-Verstärker)	237
SV 70/1 W (70-Watt-Verstärker)	238
Elv 82	239
Elv 83	240
Elv 84	241
Elv 89	242
SV 150 aW	243
SEV 201 W (20-Watt-Endstufe)	244
Elv 812 siehe Elv 82	

Elv 813 siehe Elv 83	
Elv 814	245
Elv 816	246
Elv 818	247
Elv 820	248
Elv 821	249
Elv 824	250
Elv 825	251
Elv 826	252
Elv 830	253
Elv 832 siehe Elv 824	
Elv 840	254
Elv 841	255
Elv 842	256
Elv 843	257
Elv 844	258
Elv 845	259
Elv 846 siehe Elv 844	
Elv 847	260

Star (Backnang)

Jupiter 50	263
Levante B	264
Lavente W	265
Merkur 50 GW 214	266
Merkur Luxus 50	267
Meteor	268
Meteor S	269
Neptun 50 UGW 561	270
Neptun 51 S	271
Neptun 51 U	272
Orient	273
Trabant B	274
UGW 213	275

Stafifurt

Imperial 800 WK	279
Imperial 600 WK s. Imp. 800 WK	
Imperial 400 WK	280
Imperial 400 GWK	281
Imperial 98 W	282
Imperial 65 W	283
Imperial 64 W	284

Imperial 60 WK siehe Imp. 800 WK	
Imperial 60 GWK	285
Imperial 55 W	286
Imperial 53 W	287
Imperial 53 W (mit Oktode)	288
Imperial 50 WK siehe Imp. 400 WK	
Imperial 50 GWK s. Imp. 400 GWK	
Imperial 49 W	289
Imperial 49 GW	290
Imperial 48 W	291
Imperial 48 GW	292
Imperial 47 W	293
Imperial 47 GW	294
Imperial 46 W	295
Imperial 46 GWL	296
Imperial 46 GW	297
Imperial 46 Sp. W	298
Imperial 45 W siehe Imperial 44 W	
Imperial 44 W	299
Imperial 44 G (220 V)	300
Imperial 44 G (110 V)	301
W 43	302
G 43	303
W 42	304
G 42	305
W 41 siehe W 42	
Imperial 40 W	306
Imperial 40 GW	307
LW 37	308
GWL 37	309
LW 36	310
Imperial 35 W	311
LW 35	312
GWL 35	313
Imperial 34 G	314
Imperial 34 W	315
LW 34	316
W 32	317
GL 32	318
W 31	319
LW 28	320
GWL 28	321
LW 27	322

GWL 27	323	30 A und 30/II A	362
Imperial 6 W	324	30 B siehe BT 410	
KW 5	325	8 W 35 siehe Tefadyn 340 W	
Imperial 5 A	326	6 W 16 (Ausführung I und II)	363
Imperial 5 AW	327	6 A 16 (Ausführung I und II)	364
Imperial 5 W	328	5 A	365
Imperial 5 G	329	K 5 A	366
Imperial 4 W	330	4 A 12	367
Imperial 4 BW siehe Imperial 40 W		Bandfilter-Drei	368
Imperial 4 BGW siehe Imp. 40 GW		Bandfilter 3 G	369
Imperial 3 W siehe Imperial 34 W		Bandfilter 3 W	370
Imperial 3 G siehe Imperial 34 G		Lotse GW	371
Imperial Junior	331	Lotse W	372
<i>Staudigl</i>		Lotse KG und K 134 G	373
Interpret 569 W	335	Lotse KW und K 134 W	374
Mentor II	336	Superior 35 KG	375
Studio I siehe Interpret 569 W		Superior 35 KW	376
Studio II siehe Mentor II		Superior 42 KG	377
Standard	337	Superior 42 KW	378
Tonfilmanlage K II Universal- verstärker	338	Supertefadyn GW	379
<i>Südfunk</i>		Supertefadyn W	380
Ultra	341	Tefadyn 22 W	381
<i>TAK</i>		Tefadyn 32 GW	382
1-48 H	345	Tefadyn 32 W	383
147 GW	346	Tefadyn 100 GW	384
<i>Tefag</i>		Tefadyn 100 W	385
KT 500	349	Tefadyn 150 A (Ausführung I u. II)	386
BT 410	350	Tefadyn 150 W (Ausführung I-IV)	387
T 50 A	351	Tefadyn 162 W	388
BT 400	352	Tefadyn 200 GW	389
300 W	354	Tefadyn 200 W	390
133 W	356	Tefadyn 200/38 GW	391
133 G	357	Tefadyn 200/38 W	392
K 133 W	358	Tefadyn 268 GW	393
K 133 G	359	Tefadyn 268 W	394
40 A	360	Tefadyn 308 W	395
K 33 W siehe K 133 W		Tefadyn 338 GW	396
K 33 G siehe K 133 G		Tefadyn 338 W	398
30 W und 30 II W	361	Tefadyn 340 W	400
		Zielsicher IG	402
		Zielsicher IW	403
		Zielsicher II LG	404
		Zielsicher III LW	405

<i>Tefi</i>		W 39 KW	429
GWZ 131	409	GW 39	430
Superzwerg	410	Diplomat GW	431
Super-Ultra TSR 46 GW	411	Diplomat G	432
		Diplomat W	433
<i>TEKADE (Produktion nach 1945)</i>		Franken	434
GWK 482	415	Herzog W I	435
GWK 481	416	Herzog W II	436
GWB 167	417	KES 41 GWK	437
WK 50 Edelklang	418	KES 41 WK	438
GWK 50 Edelklang	419	Konsul W	439
GWK 48	420	LES 41 GW	440
WK 47	421	LES 41 GWK	441
WK 45	422	LES 43 KML	442
WK 065 und WKZ 065	423	MES 41 WK	443
UKW-Einbaugerät	424	Oberon W	444
		Orlando GW	445
<i>TEKADE (Produktion vor 1945)</i>		Orlando W	446
WK 40	427	Sirius W	447
W 39	428	WA 22 (20-Watt-Vollverstärker)	448

SIEMENS

(Produktion nach 1945)

Siemens SH III5 W Spitzensuper 52

(linke Seite des Schaltbildes)

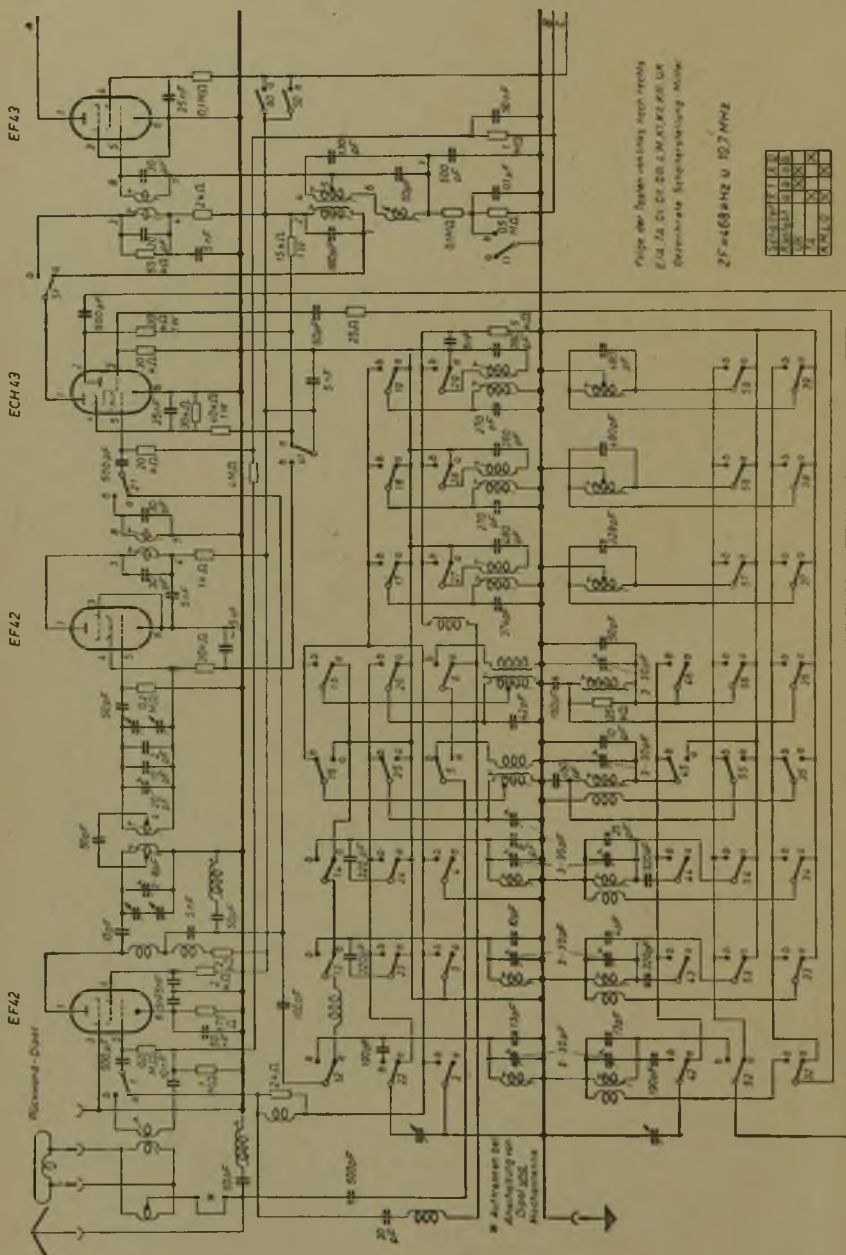

Siemens SH III5 W Spitzensuper 52

(rechte Seite des Schaltbildes)

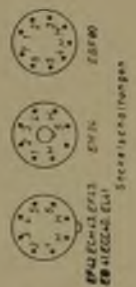
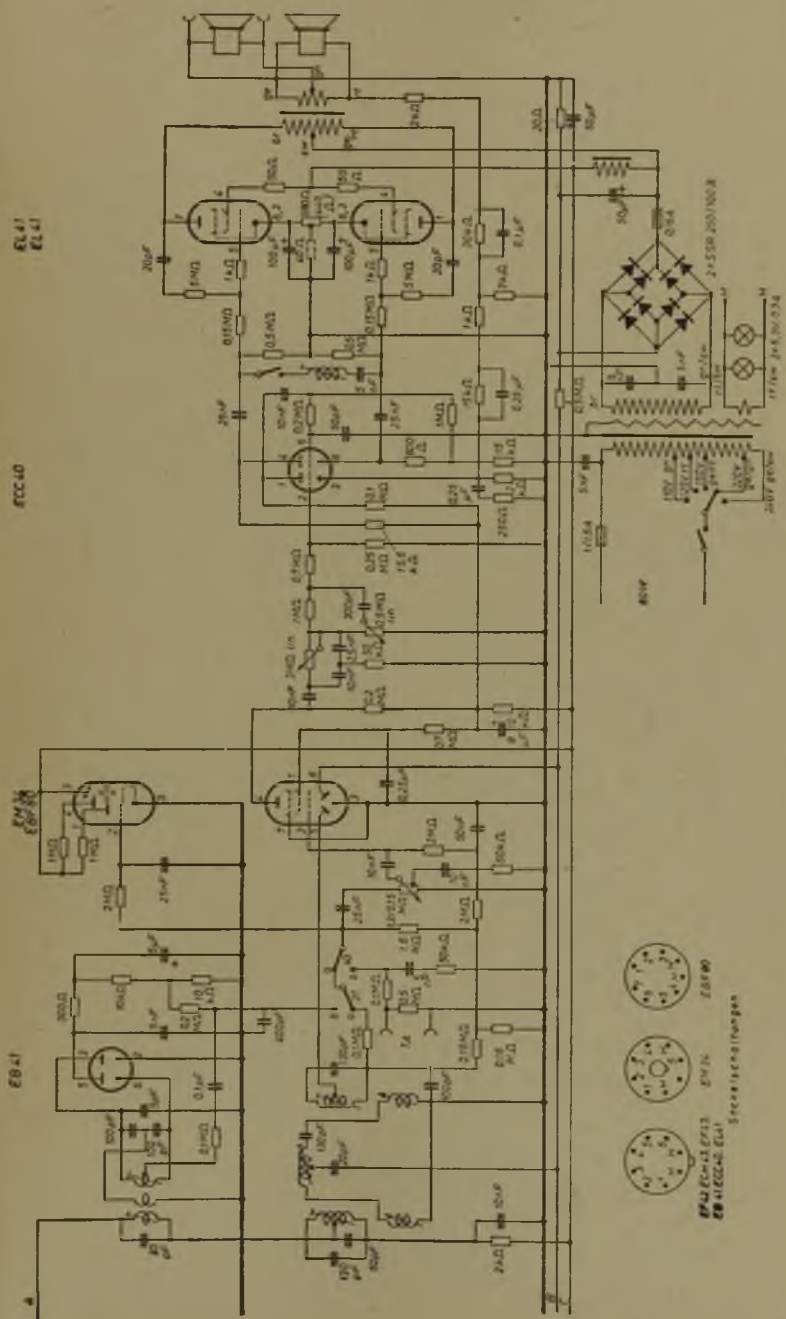

Siemens SH 906 W Spitzensuper 51

(linke Seite des Schaltbildes)

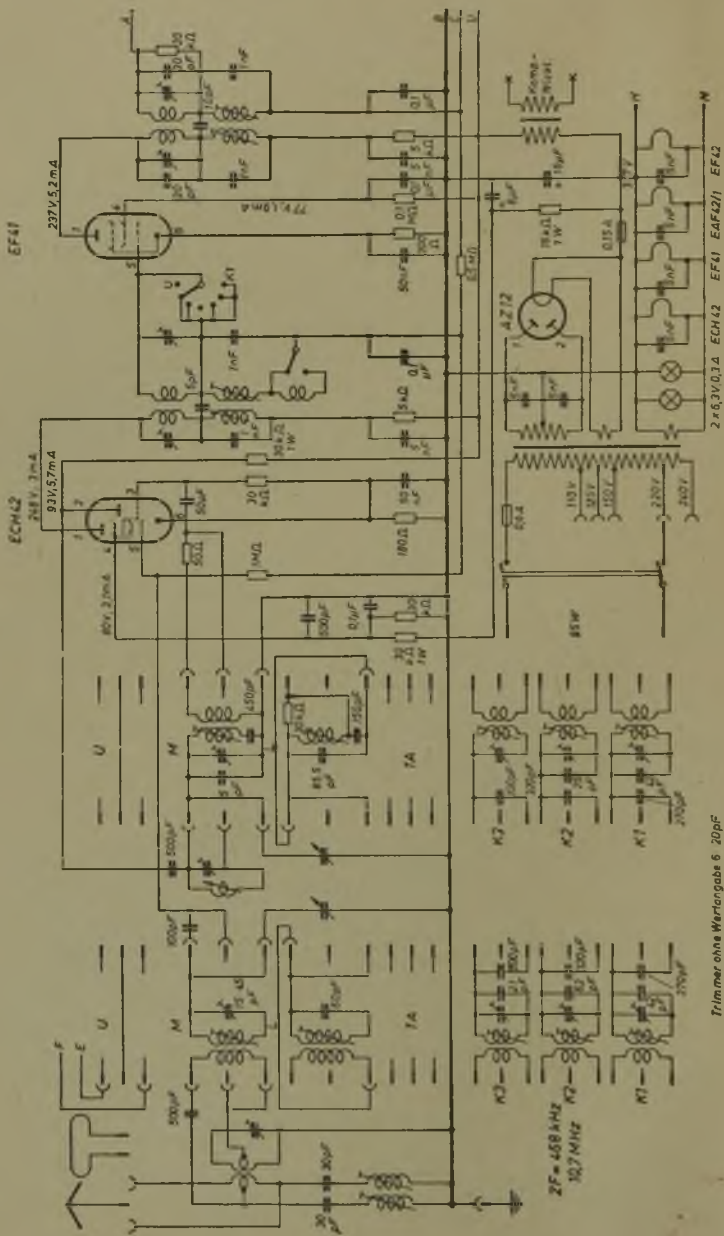

Trimmer ohne Wertangabe 6 · 20pF

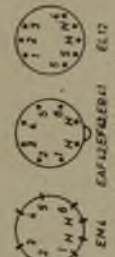
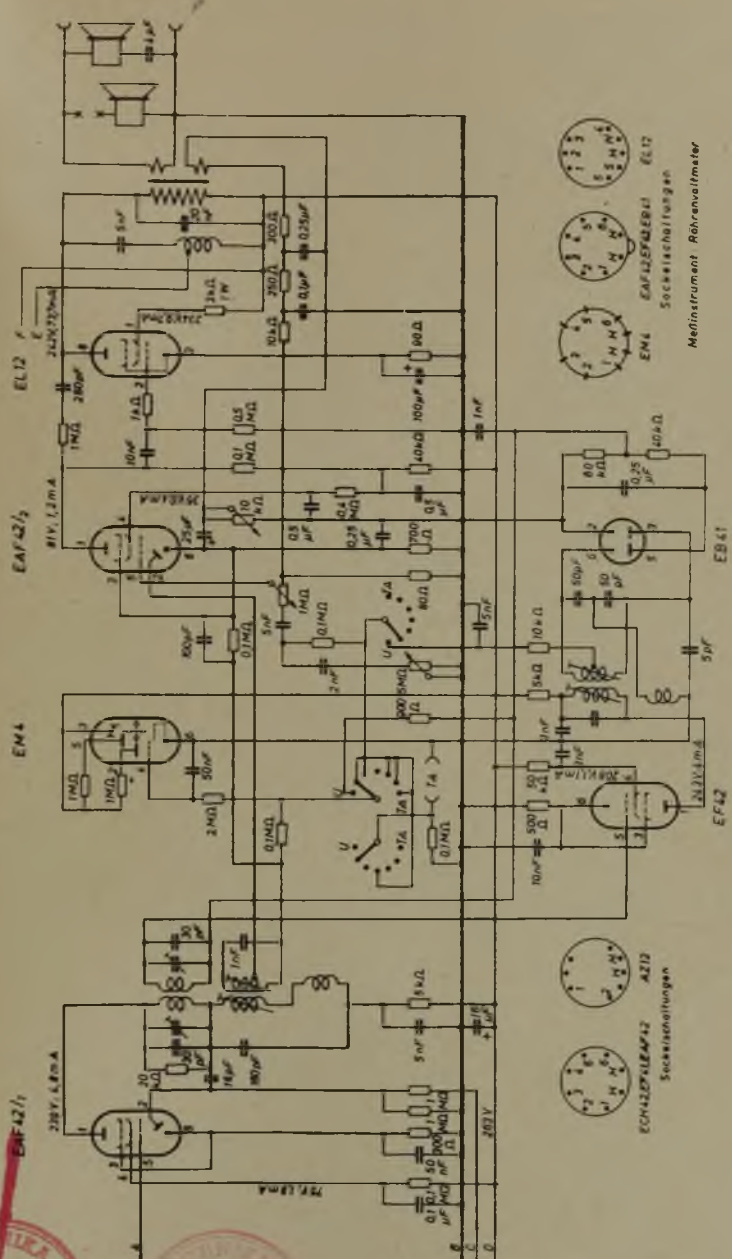

Maßstab 1:1
Mehrfachrohr
Socketanschaltungen

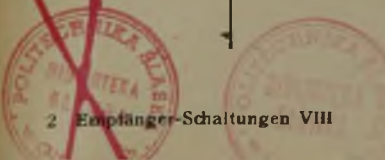

Siemens SH 816 W Phonosuper 52

EM34
EL 01

EB 47
EAF 42

EAF 42

EF80
ECH 42

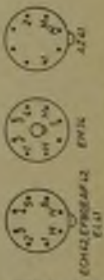
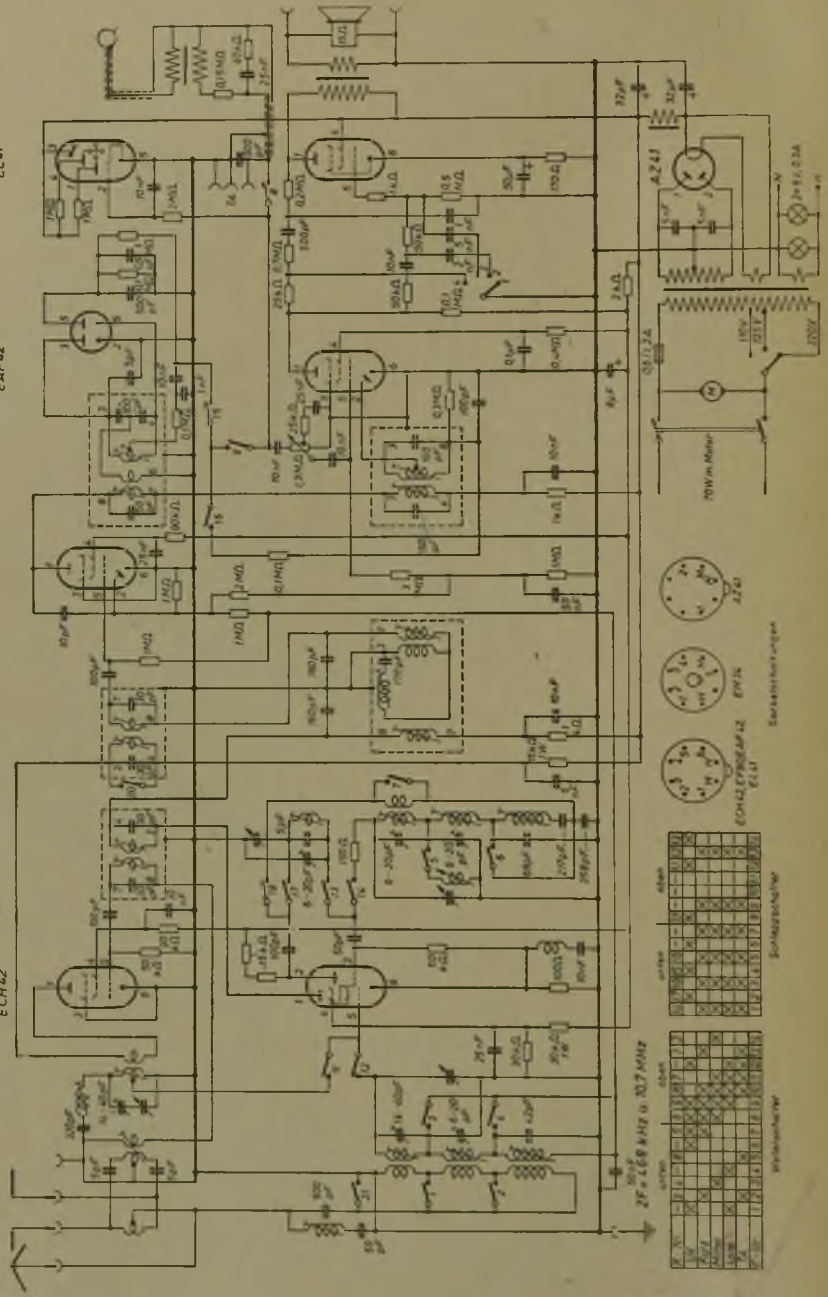

EM34 EL 01

1	2	3	4	5	6	7	8	9	10
1	2	3	4	5	6	7	8	9	10
1	2	3	4	5	6	7	8	9	10
1	2	3	4	5	6	7	8	9	10

EB 47 EAF 42

1	2	3	4	5	6	7	8	9	10
1	2	3	4	5	6	7	8	9	10
1	2	3	4	5	6	7	8	9	10
1	2	3	4	5	6	7	8	9	10

EF80 ECH 42

1	2	3	4	5	6	7	8	9	10
1	2	3	4	5	6	7	8	9	10
1	2	3	4	5	6	7	8	9	10
1	2	3	4	5	6	7	8	9	10

EM 34 EL 01

EB 47 EAF 42

EF 80 ECH 42

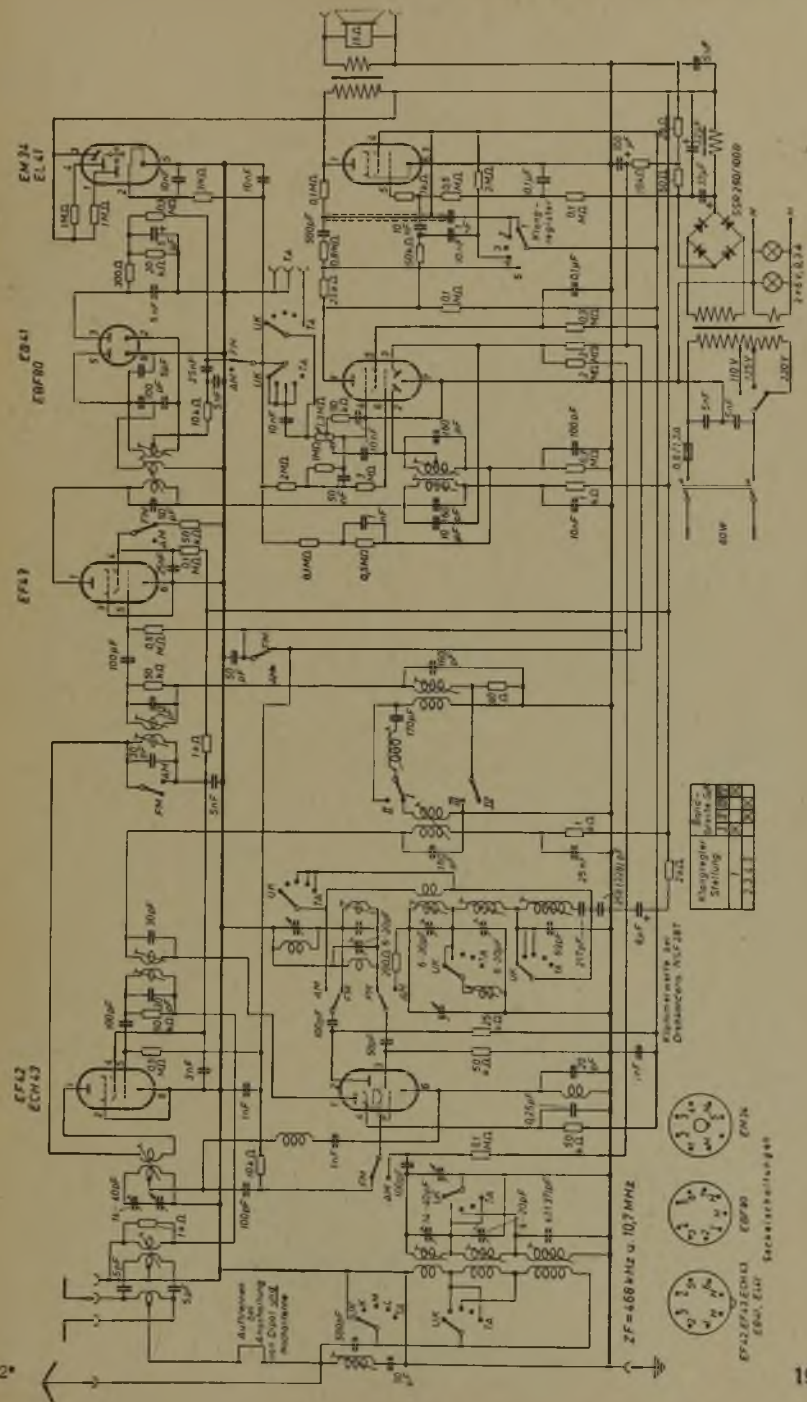

Bezeichnung	Wert	Einheit
Widerstand	100	Ω
Widerstand	1000	Ω
Widerstand	10000	Ω
Widerstand	100000	Ω
Widerstand	1000000	Ω
Widerstand	10000000	Ω
Widerstand	100000000	Ω
Widerstand	1000000000	Ω
Kapazität	10	pF
Kapazität	100	pF
Kapazität	1000	pF
Kapazität	10000	pF
Kapazität	100000	pF
Kapazität	1000000	pF
Kapazität	10000000	pF
Kapazität	100000000	pF
Kapazität	1000000000	pF

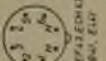
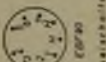
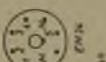

EF43 6X4
 EF41 6X4
 EM31 6X4
 250V AC
 500µF
 1000000000 pF
 100000000 pF
 10000000 pF
 1000000 pF
 100000 pF
 10000 pF
 1000 pF
 100 pF
 10 pF
 1 pF
 100 Ω
 1000 Ω
 10000 Ω
 100000 Ω
 1000000 Ω
 10000000 Ω
 100000000 Ω
 1000000000 Ω
 10000000000 Ω
 100000000000 Ω
 1000000000000 Ω

ZF = 468 kHz u. 10,7 MHz

Siemens SH 813 W Qualitätssuper 52

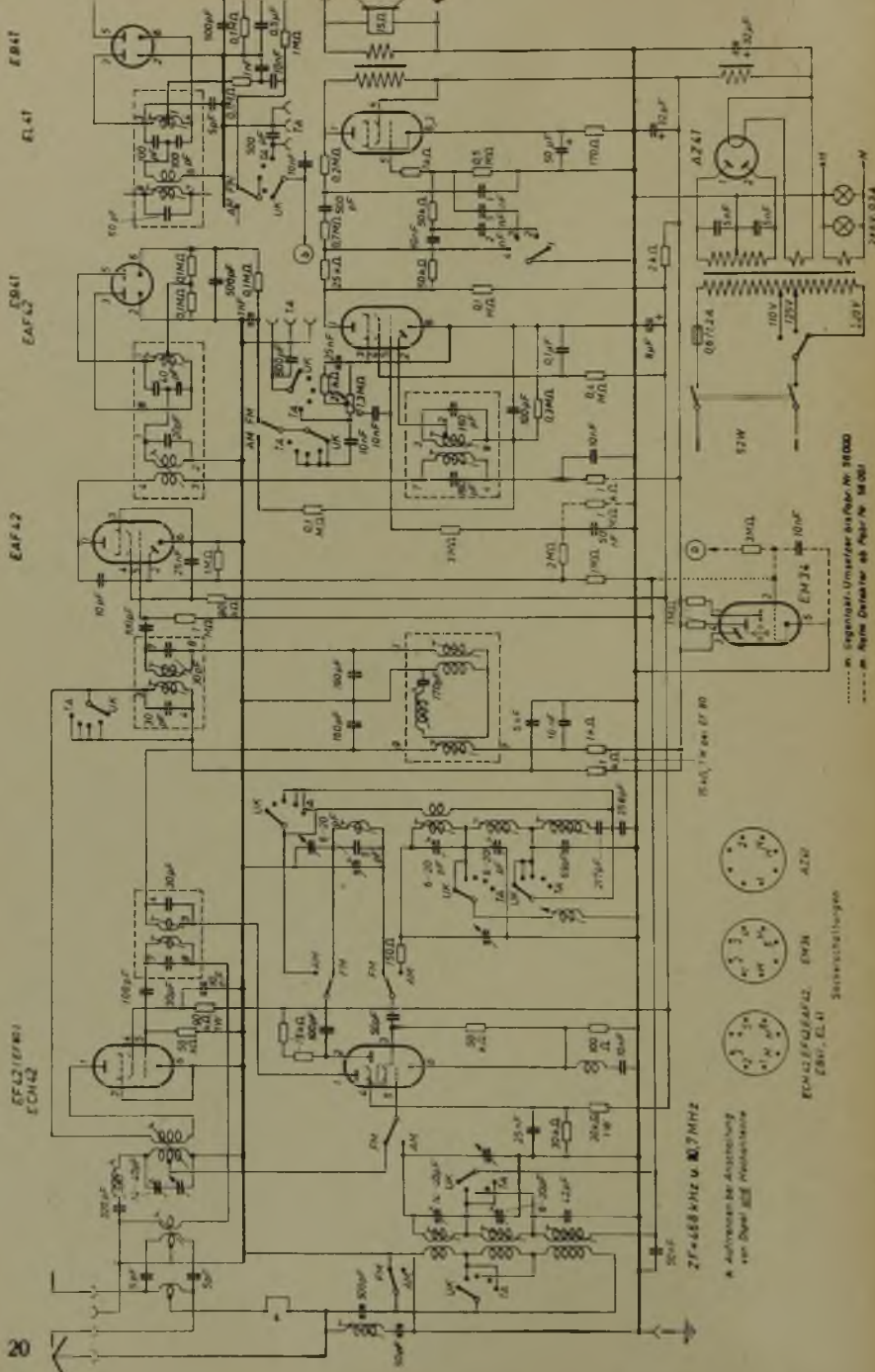

... m. Original-Umschalter auf Fol. Nr. 38000
 ... m. Neig. Detektor ab Fol. Nr. 14000

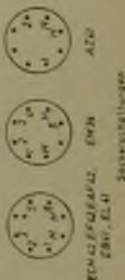

ECH2 (EFA2) EFA1 (EFA1) A247 (A247)
 SEITE 15/16

ZF 455 kHz u. 7 MHz
 * Aufdrucke für Abgleichung
 von Digital-ELF-Produktions

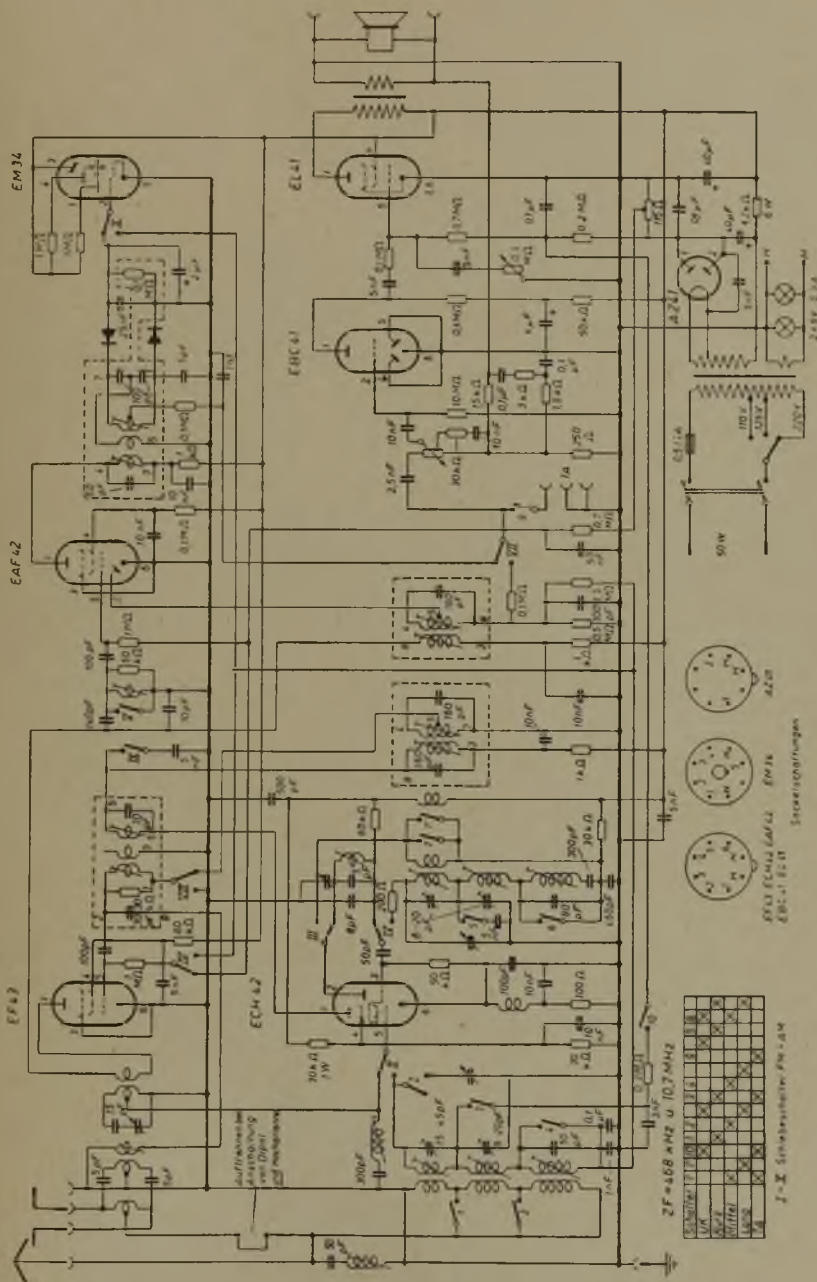

Siemens **SB 780 W** Schatulle und **SB 700 W**
 (rechte Seite des Schaltbildes)

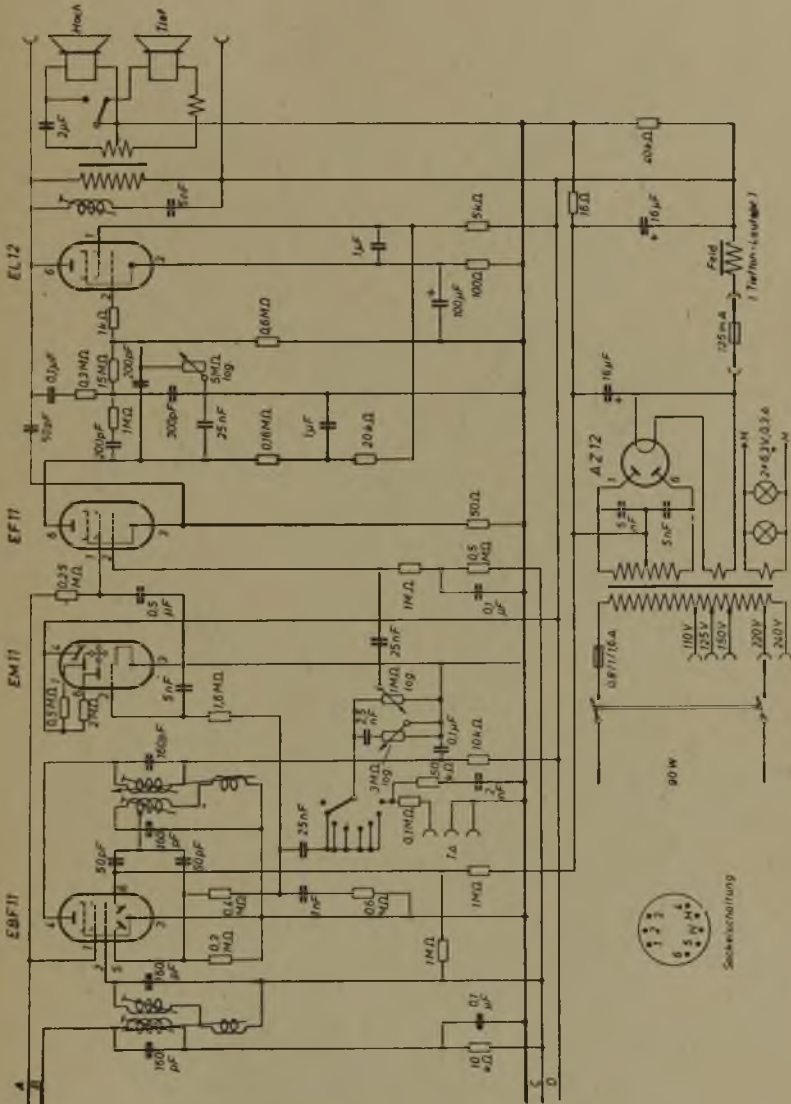

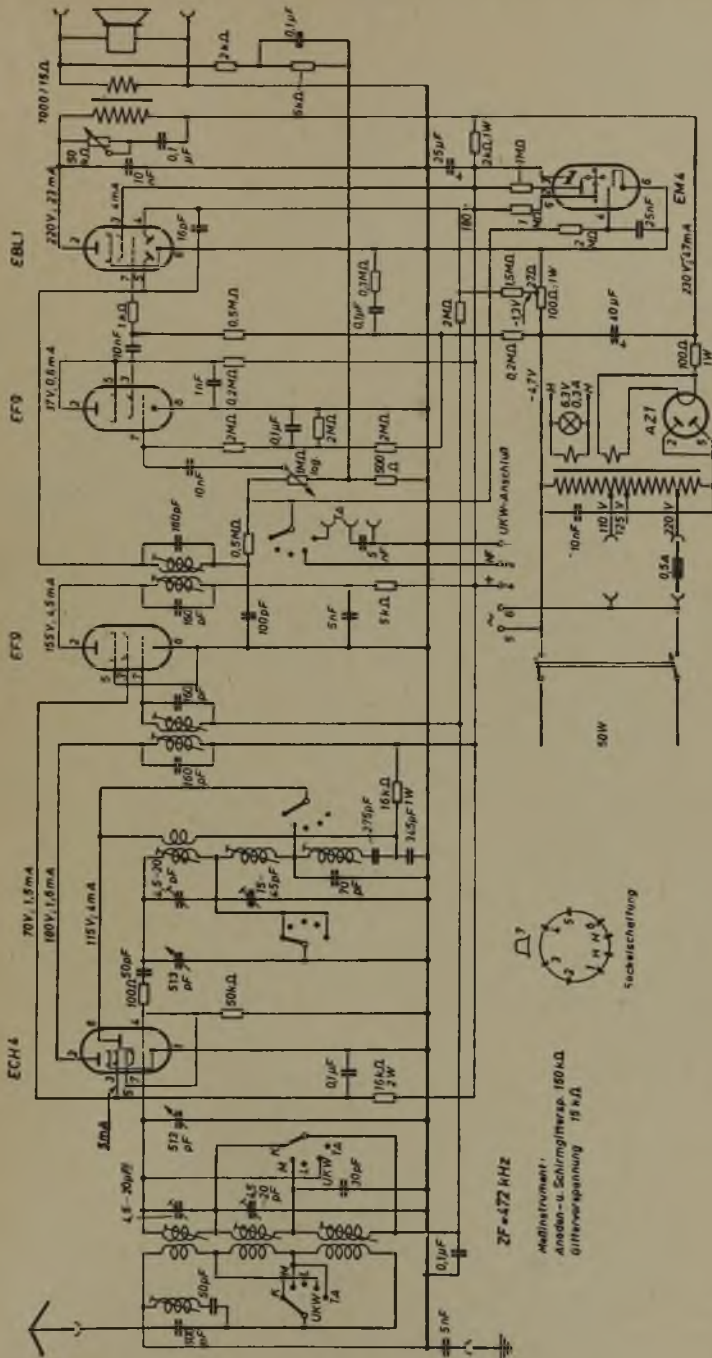

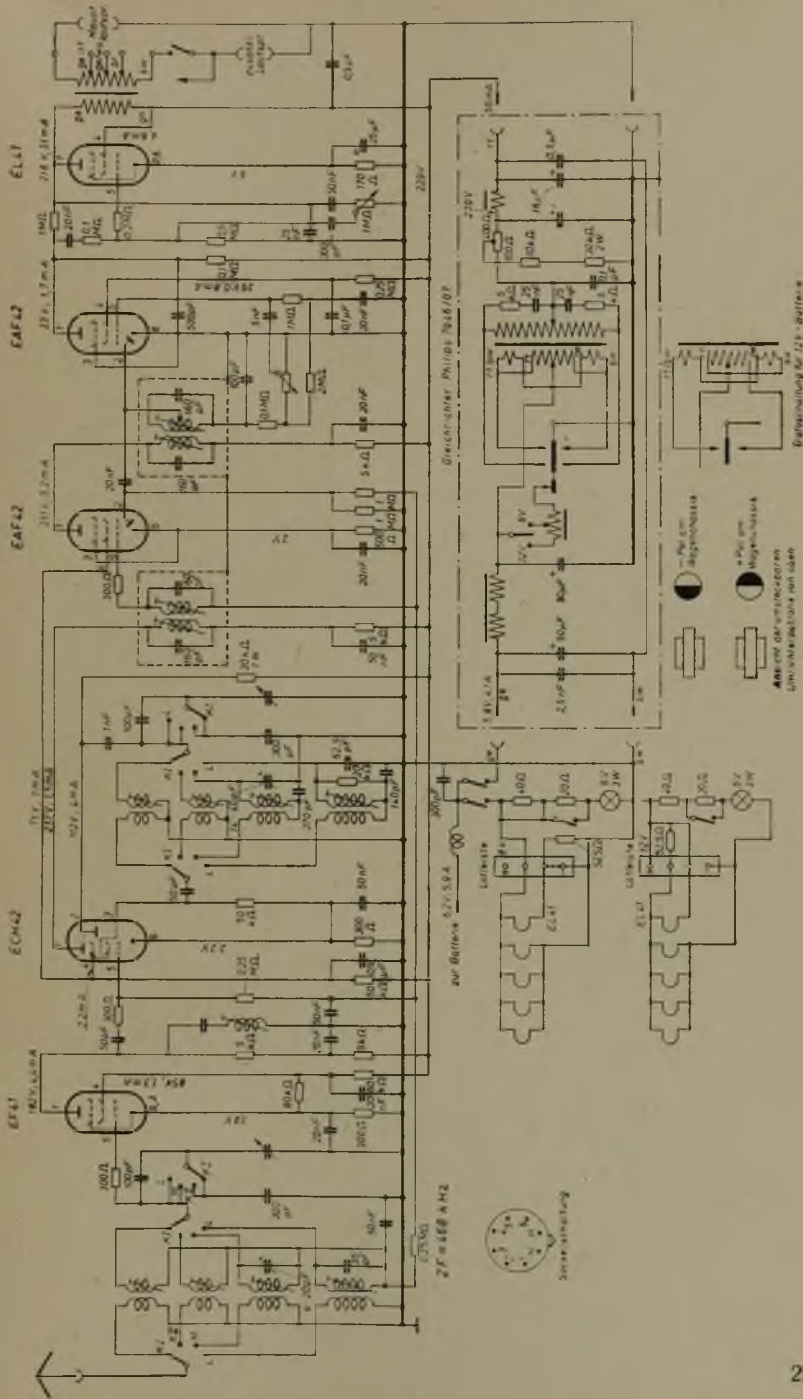

Siemens SH 598 W Symphonie
SH 479 W Melodie II und TM 1 Musiktube

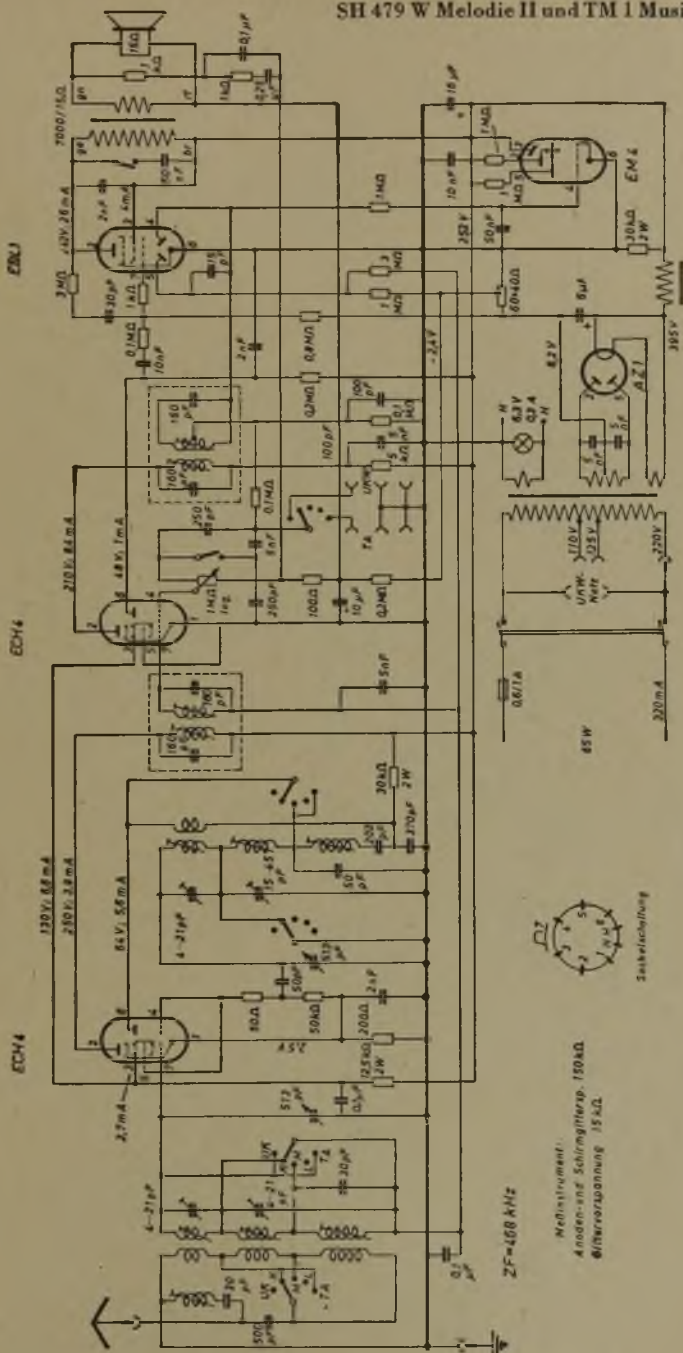

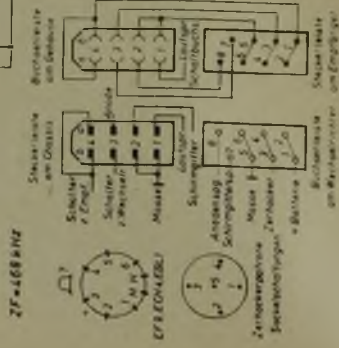
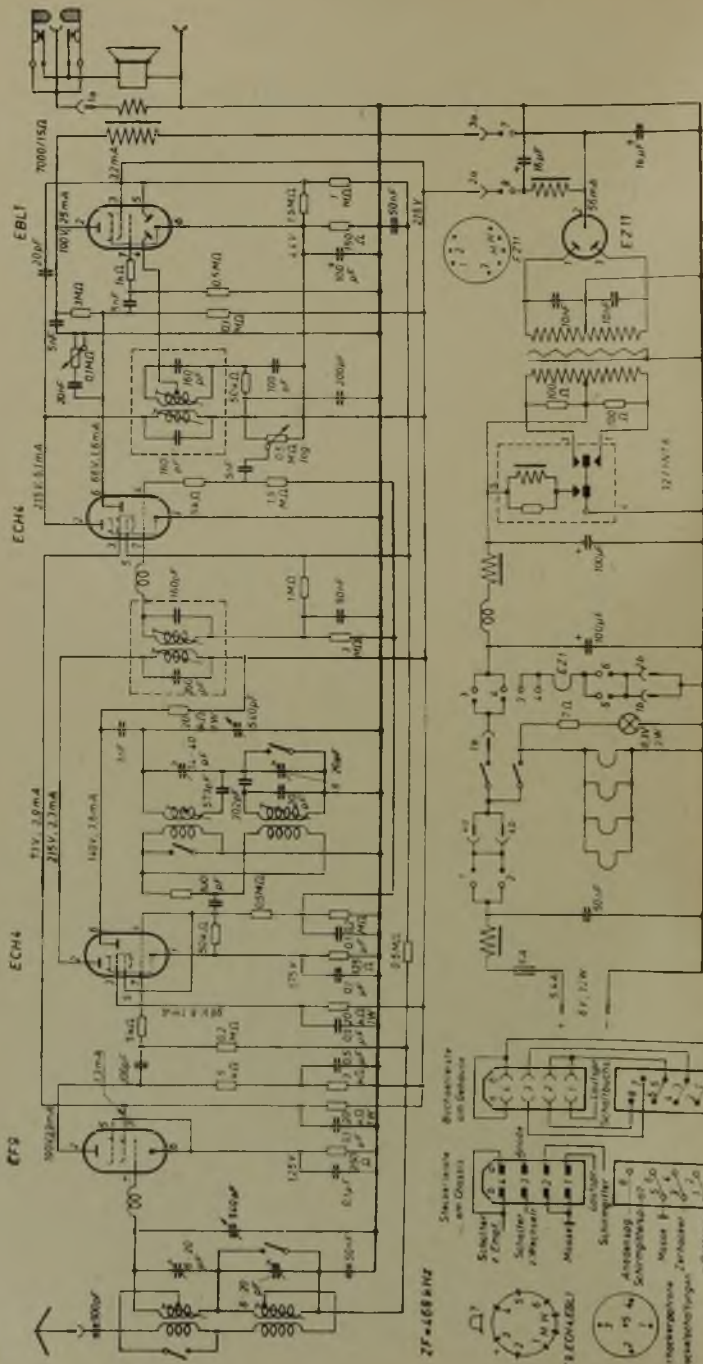

Multi-Element-Gruppe in Schirmgitter 100kΩ
Wähltrieb
111.5

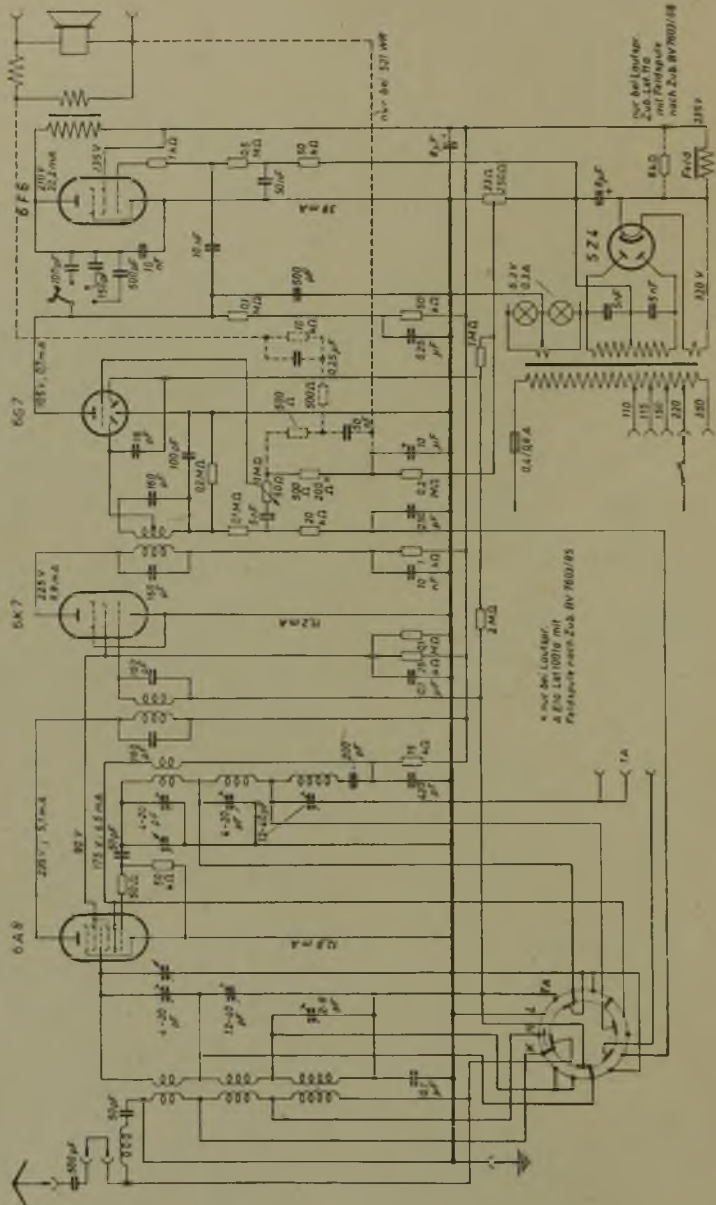

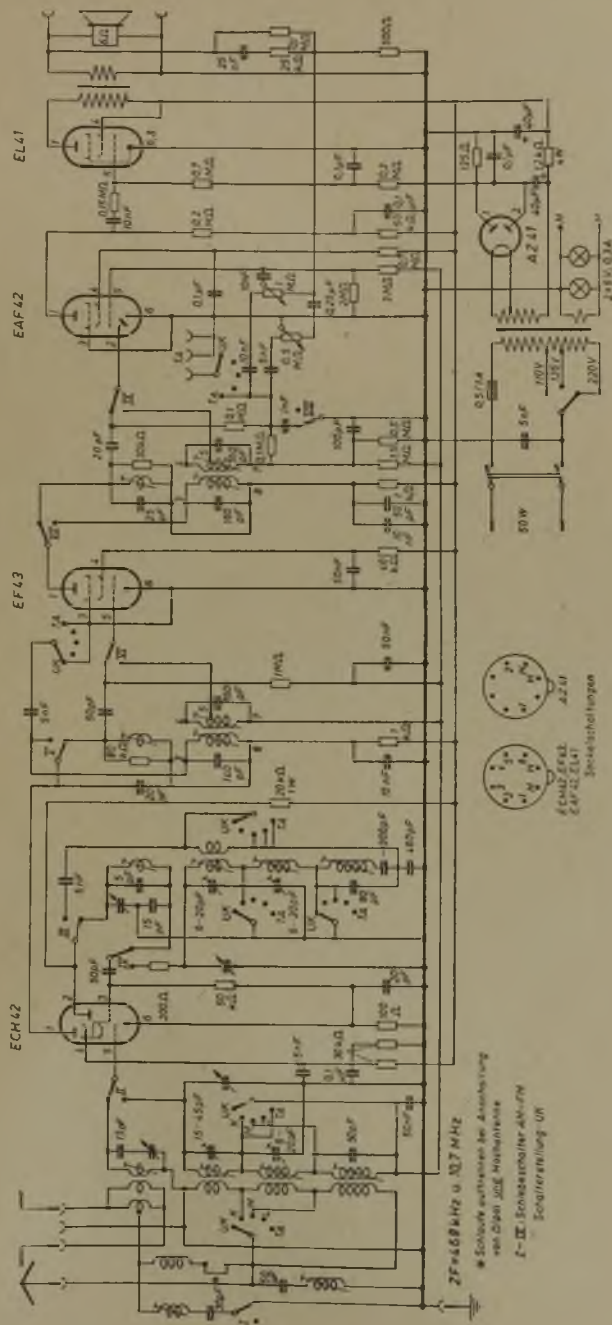

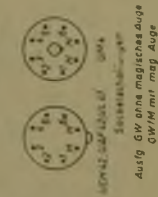
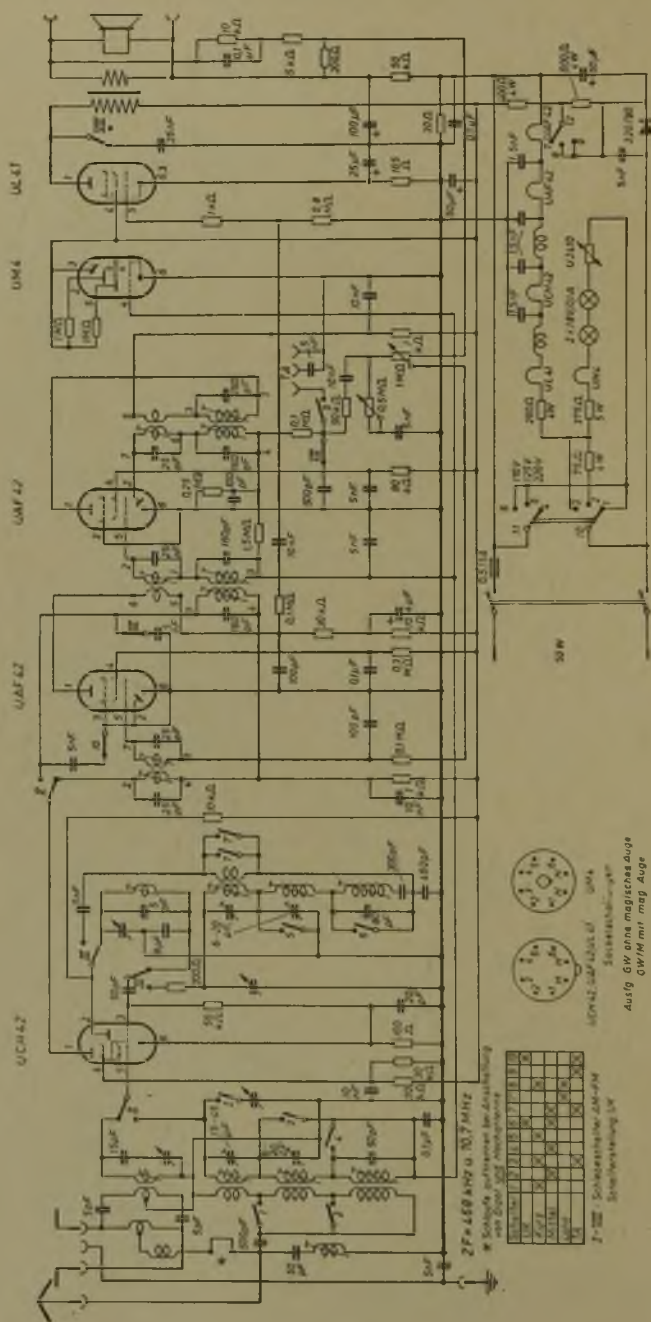

Ausg. GW ohne magisches Auge
 GW/M mit mag. Auge

Siemens SB 502 W Spezialsuper 51

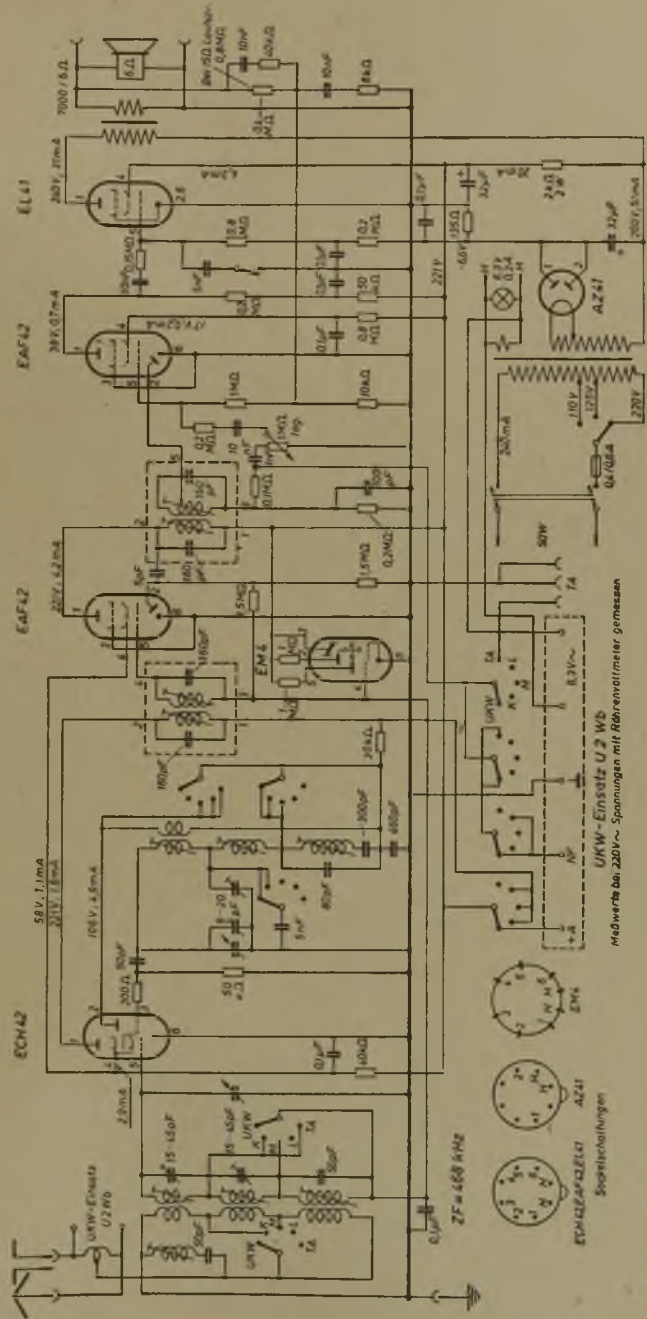

Siemens SB 502 GW Spezialsuper 51

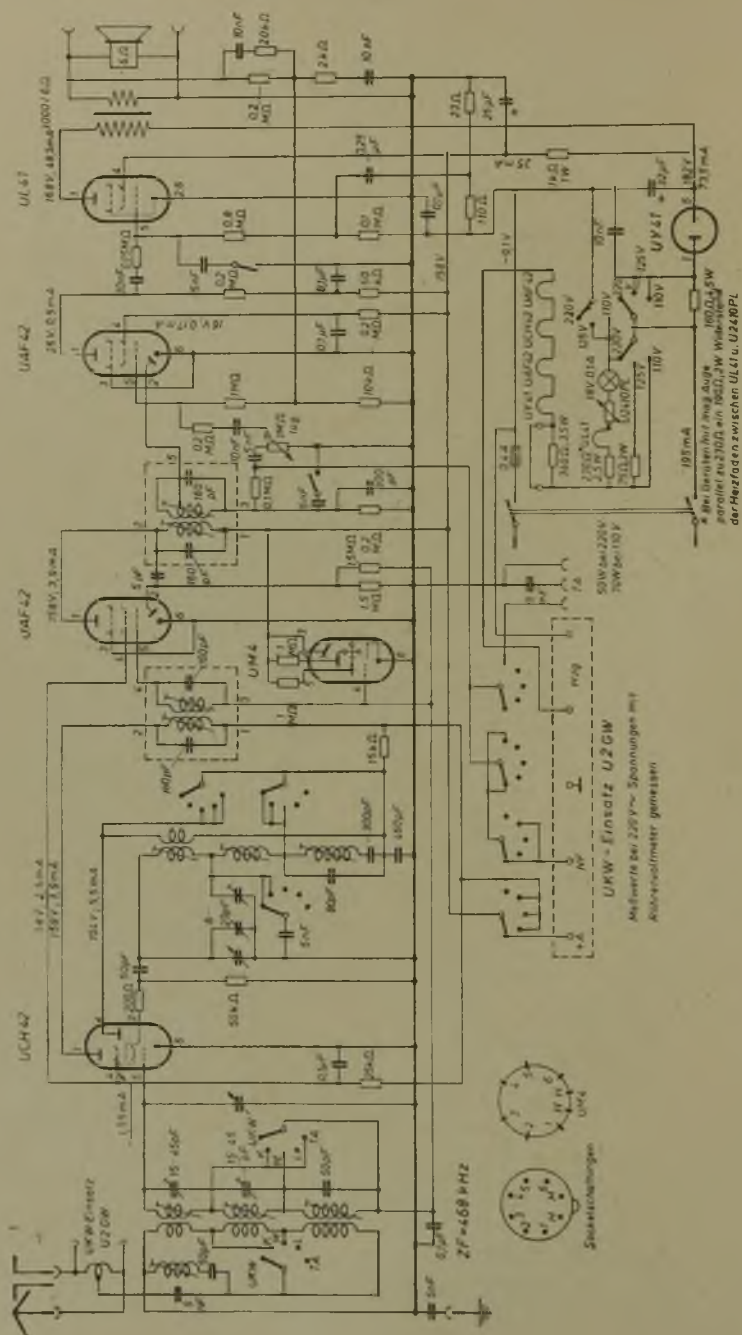

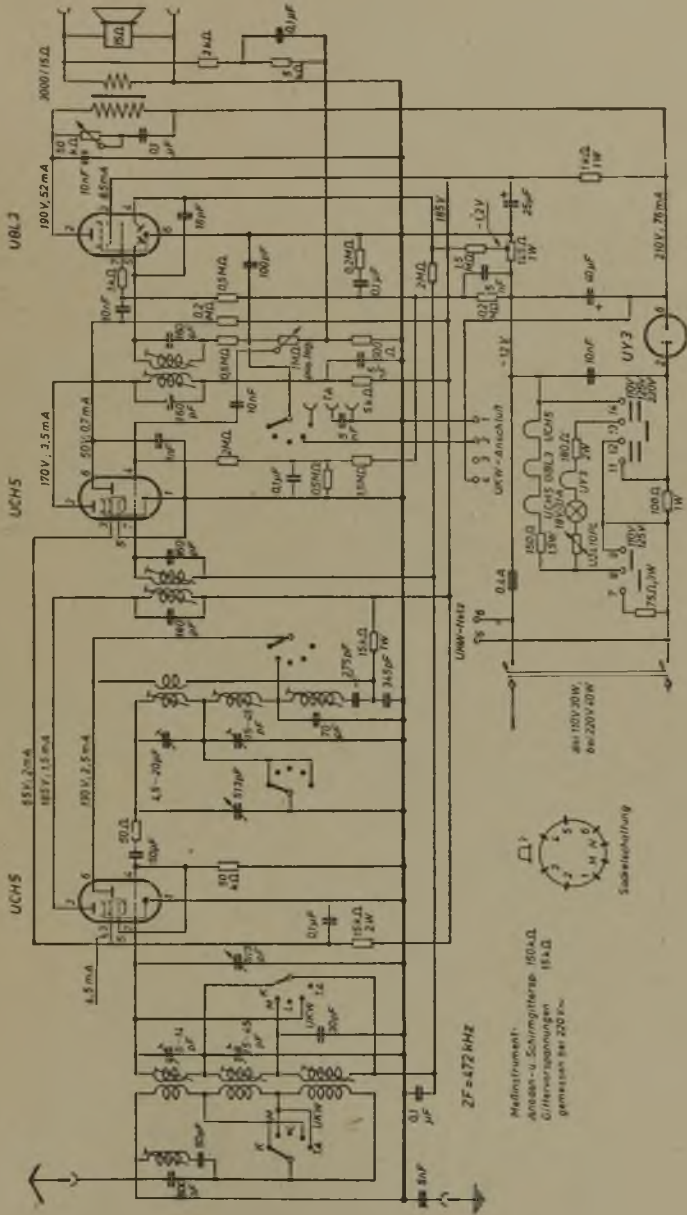

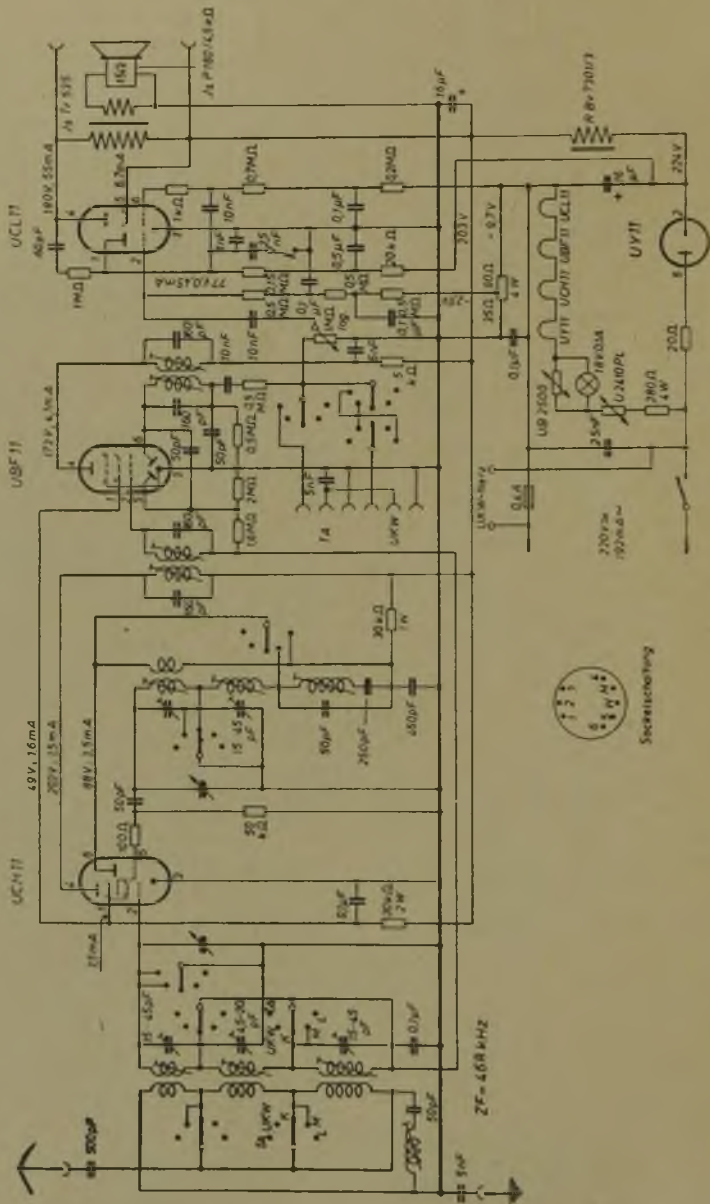

Sockelanschl.

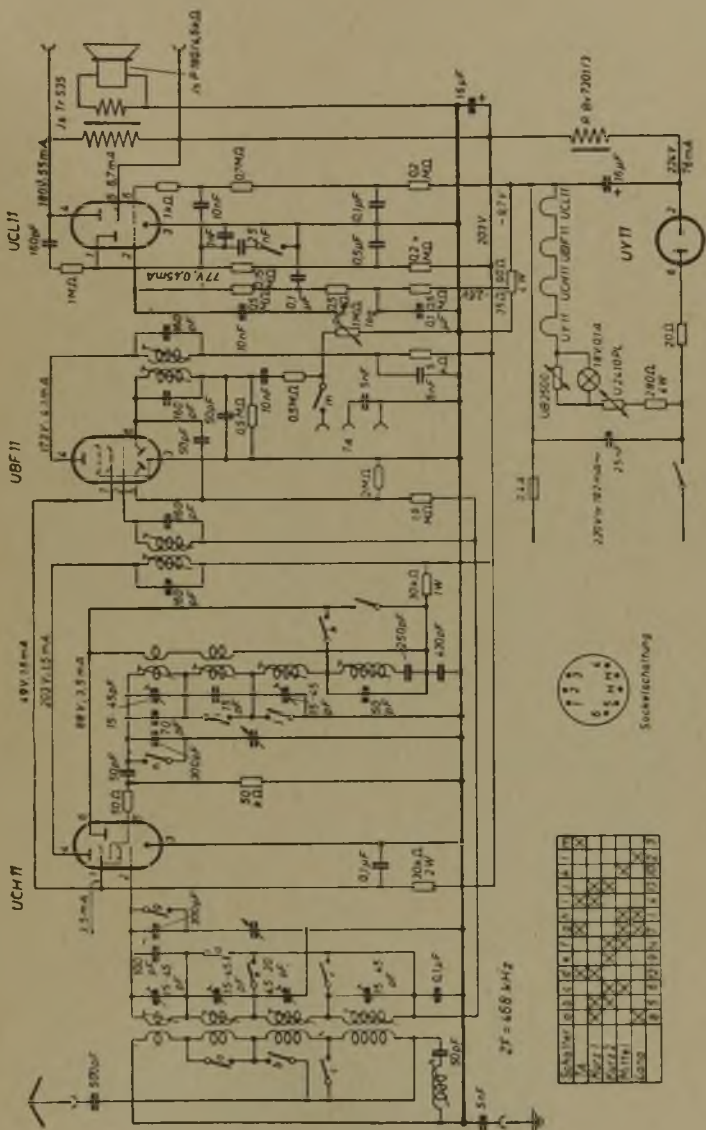

1	2	3	4	5	6	7	8	9	10	11	12
13	14	15	16	17	18	19	20	21	22	23	24
25	26	27	28	29	30	31	32	33	34	35	36
37	38	39	40	41	42	43	44	45	46	47	48
49	50	51	52	53	54	55	56	57	58	59	60
61	62	63	64	65	66	67	68	69	70	71	72
73	74	75	76	77	78	79	80	81	82	83	84
85	86	87	88	89	90	91	92	93	94	95	96
97	98	99	100	101	102	103	104	105	106	107	108
109	110	111	112	113	114	115	116	117	118	119	120

Suchschaltung



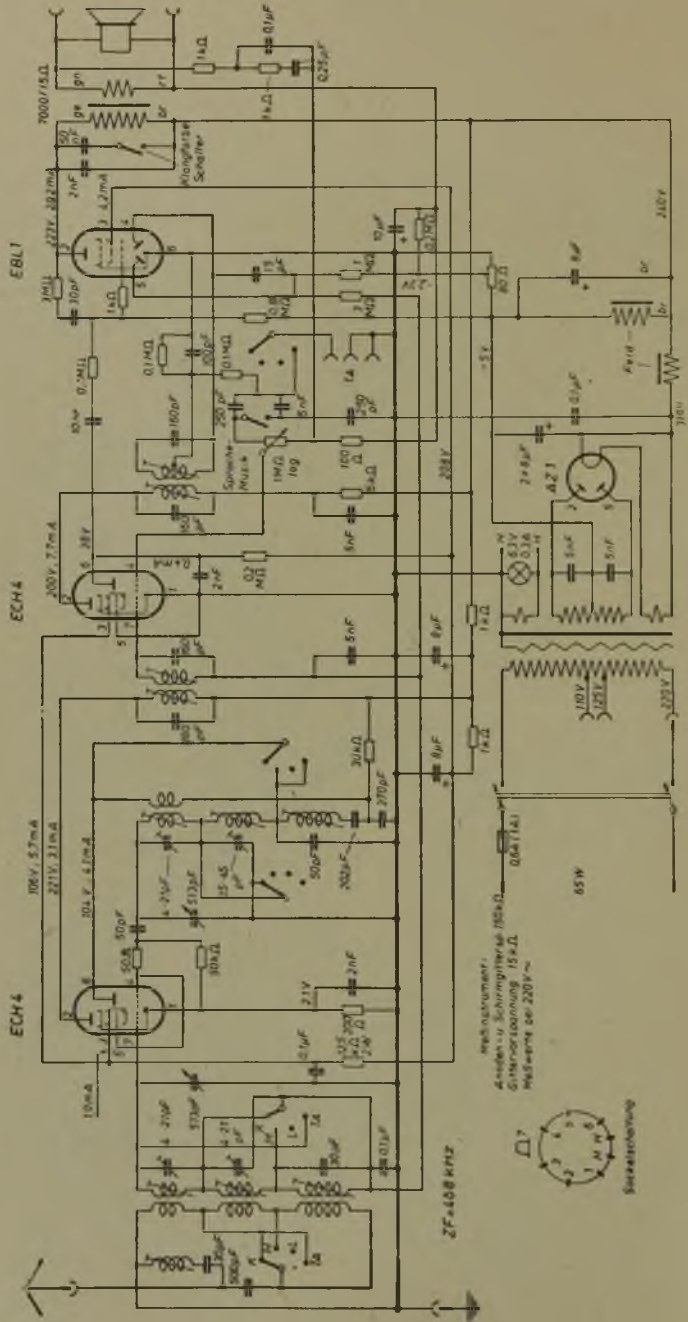

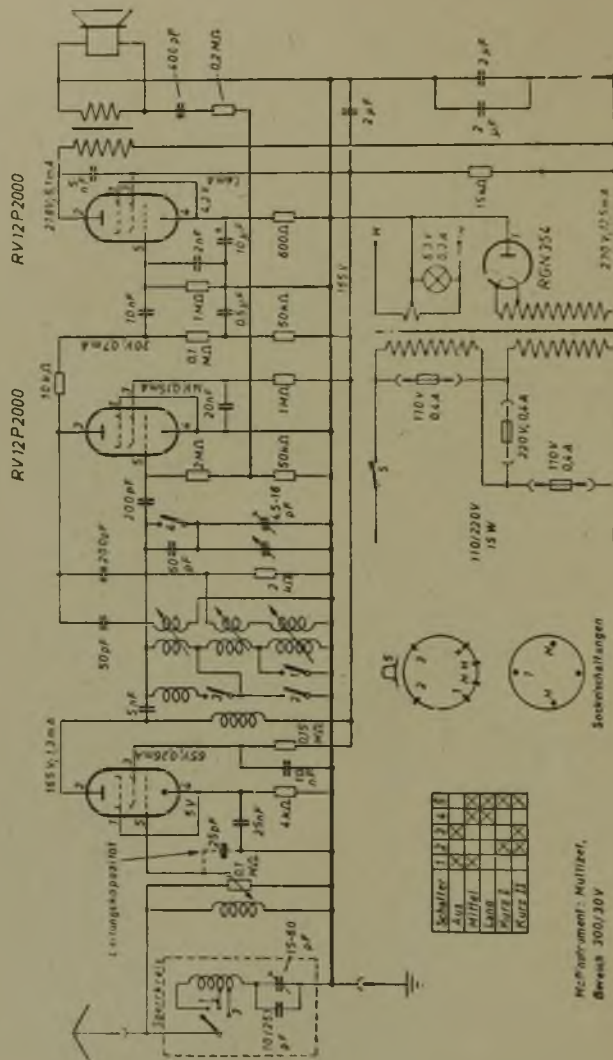

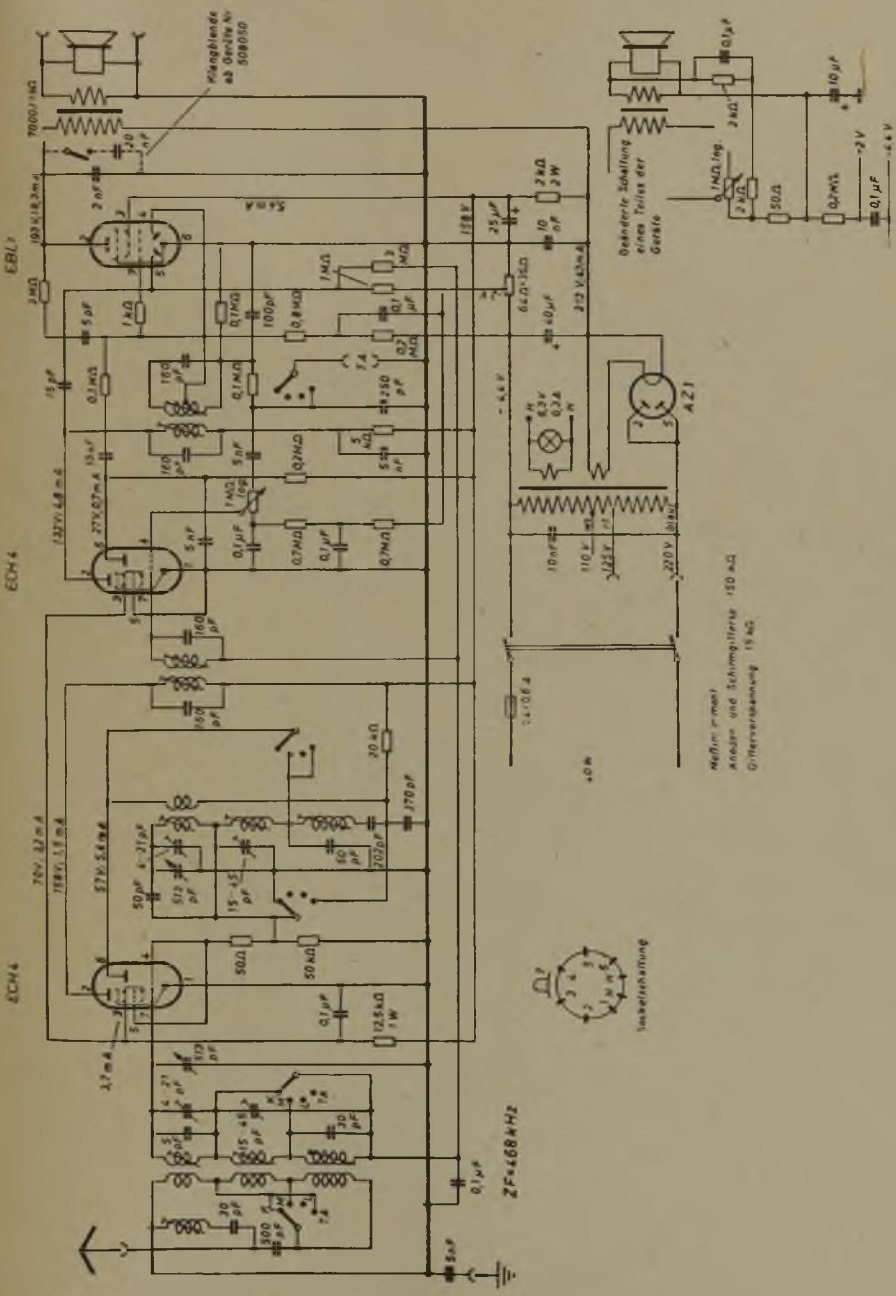

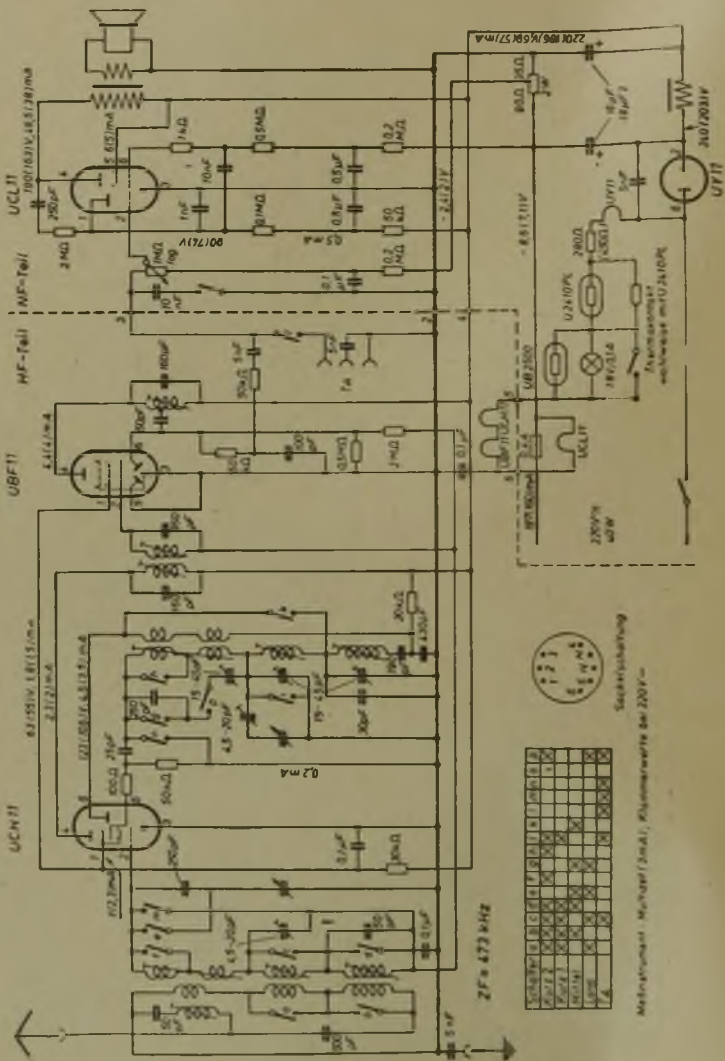

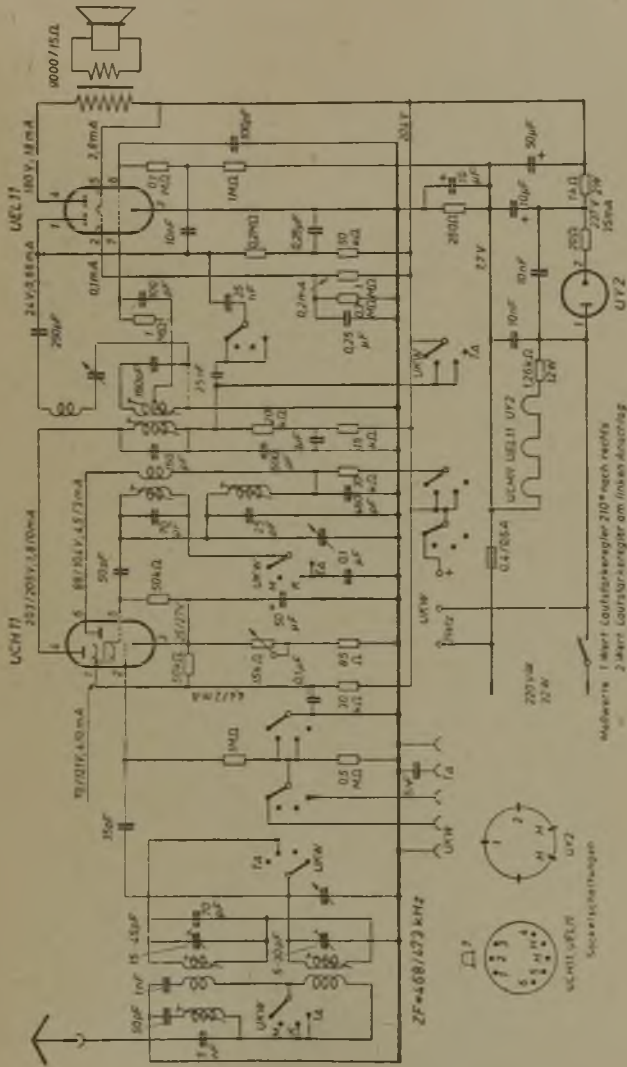

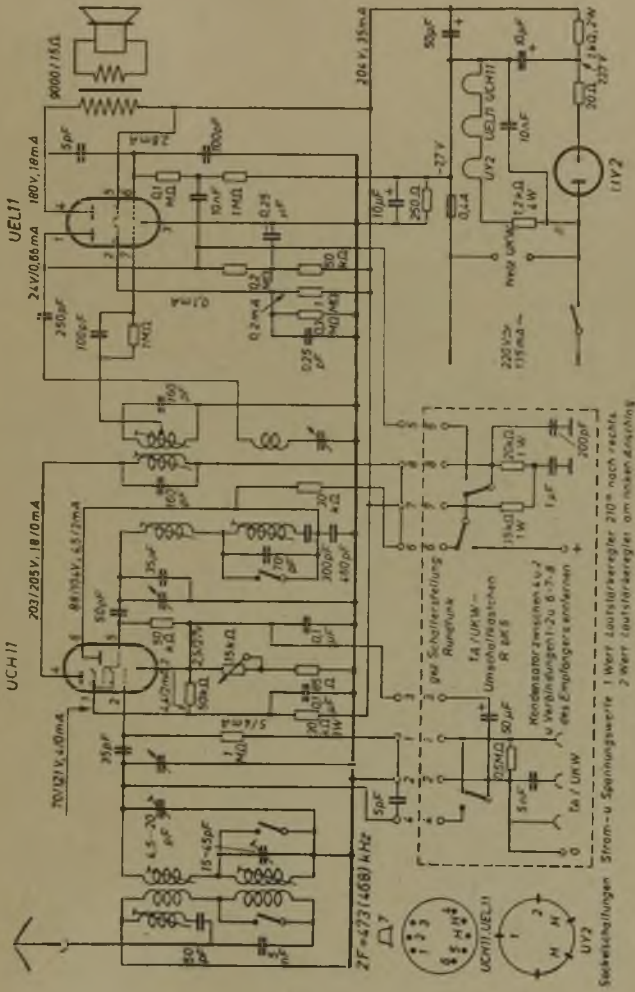

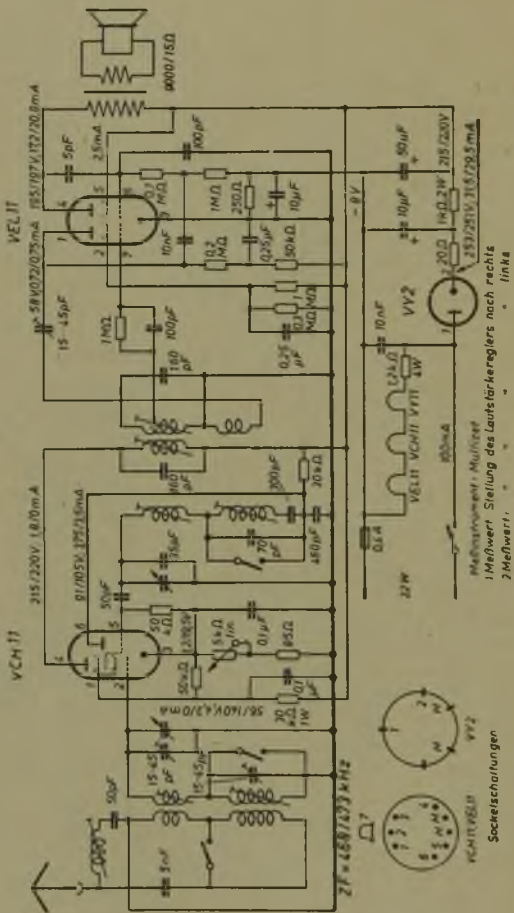

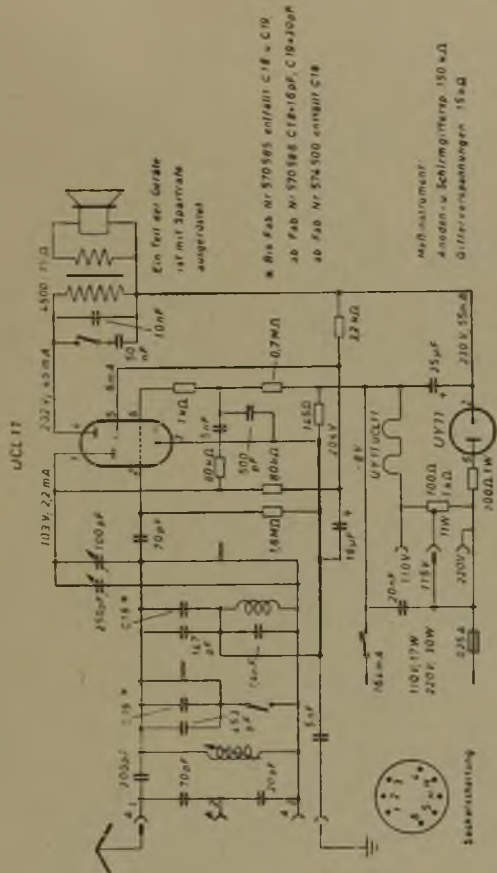

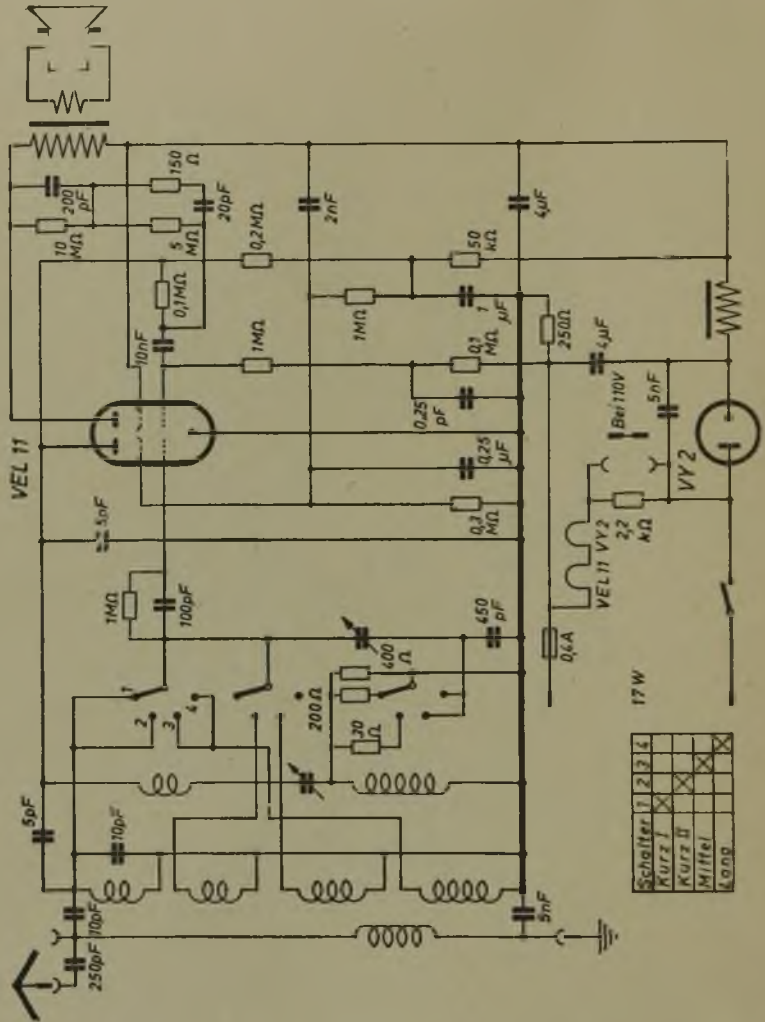

Schalter	1	2	3	4
Kurz I		X		
Kurz II			X	
Mittel				X
Long				

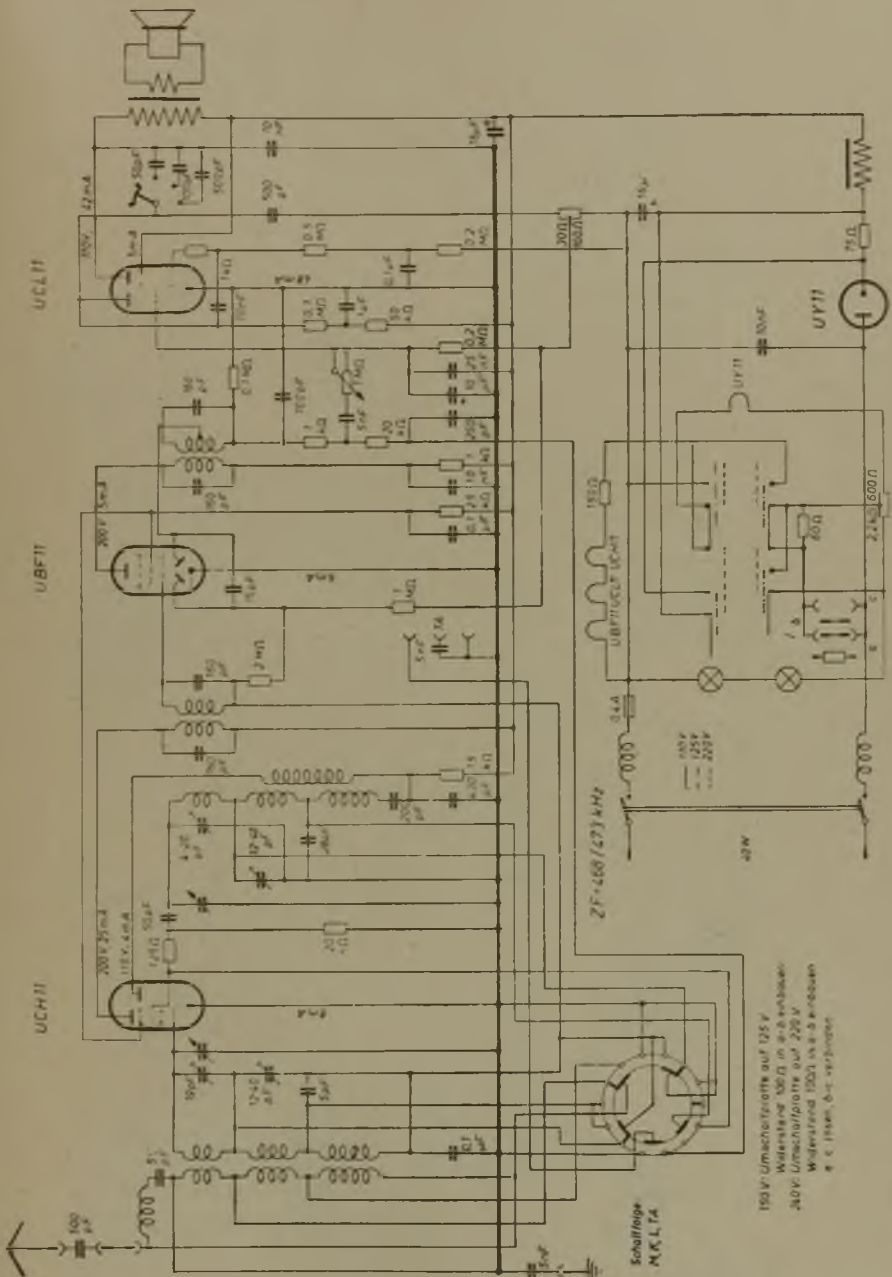

Siemens U4 Wt und U4 GWt (UKW-Einsatz)

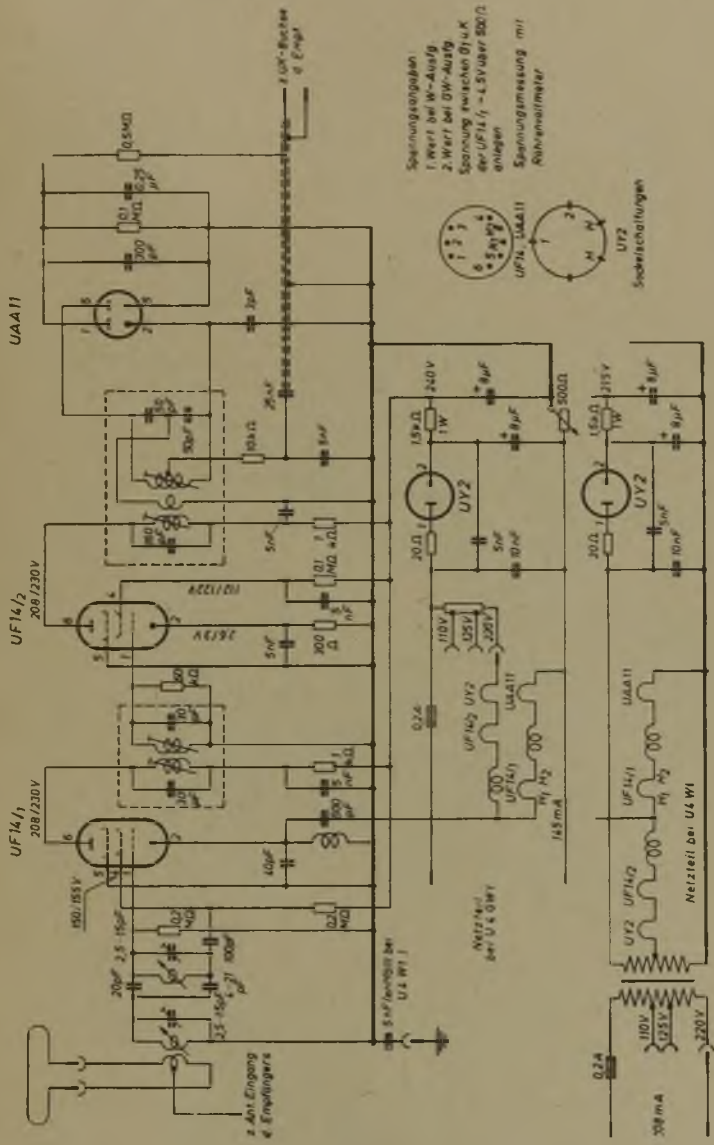

- Spannungsgaben:**
- 1 Wert bei W-Ausg.
 - 2 Wert bei GW-Ausg.
- Spannung weichen 8% u. K
bei UF14₁ -LS-Varier 800Ω
einlegen
- Spannungsmessung mit
Röhrenvoltmeter



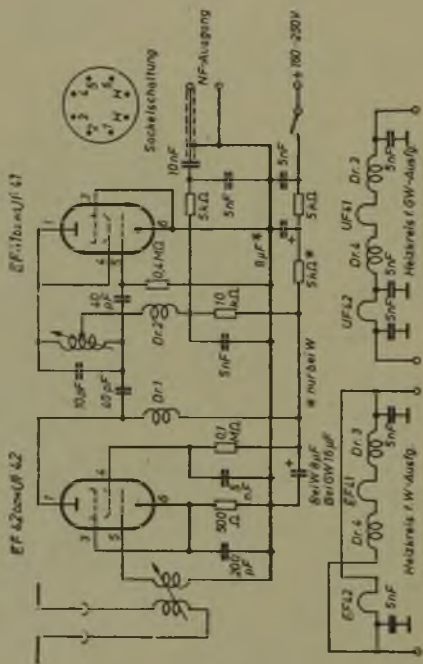

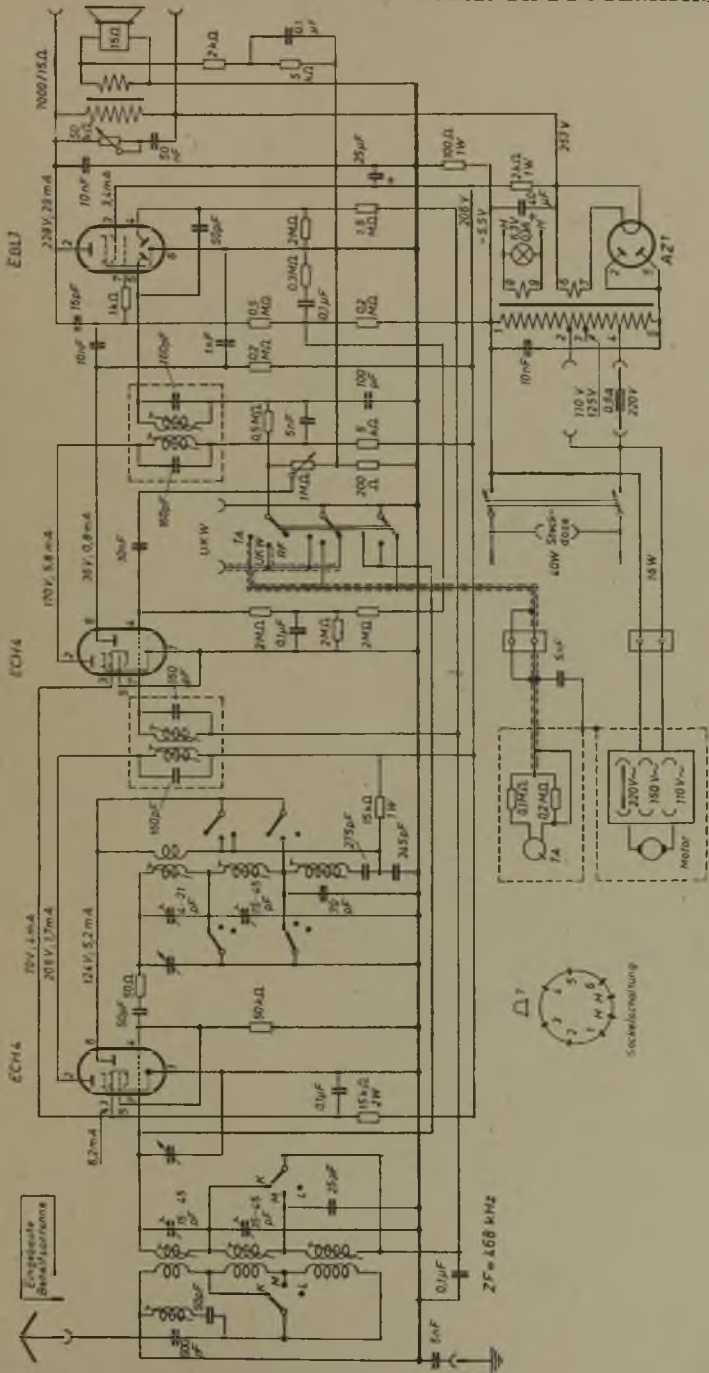

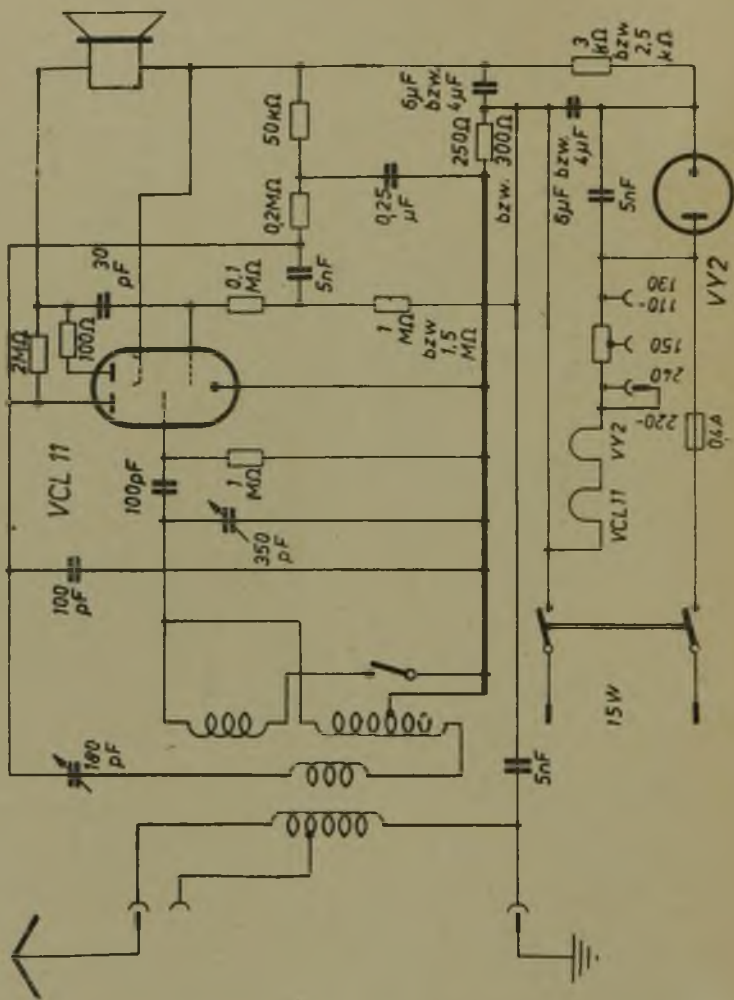

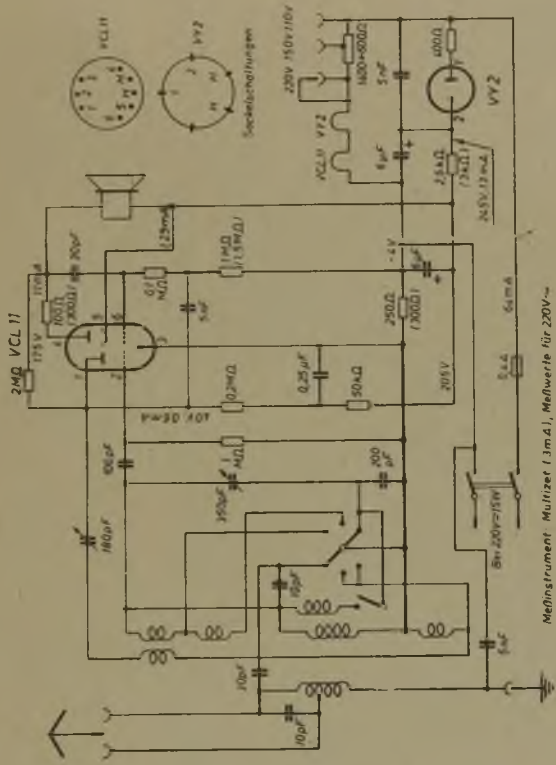

Meßinstrument Multizer (10mA), Meßwerte für 220V~

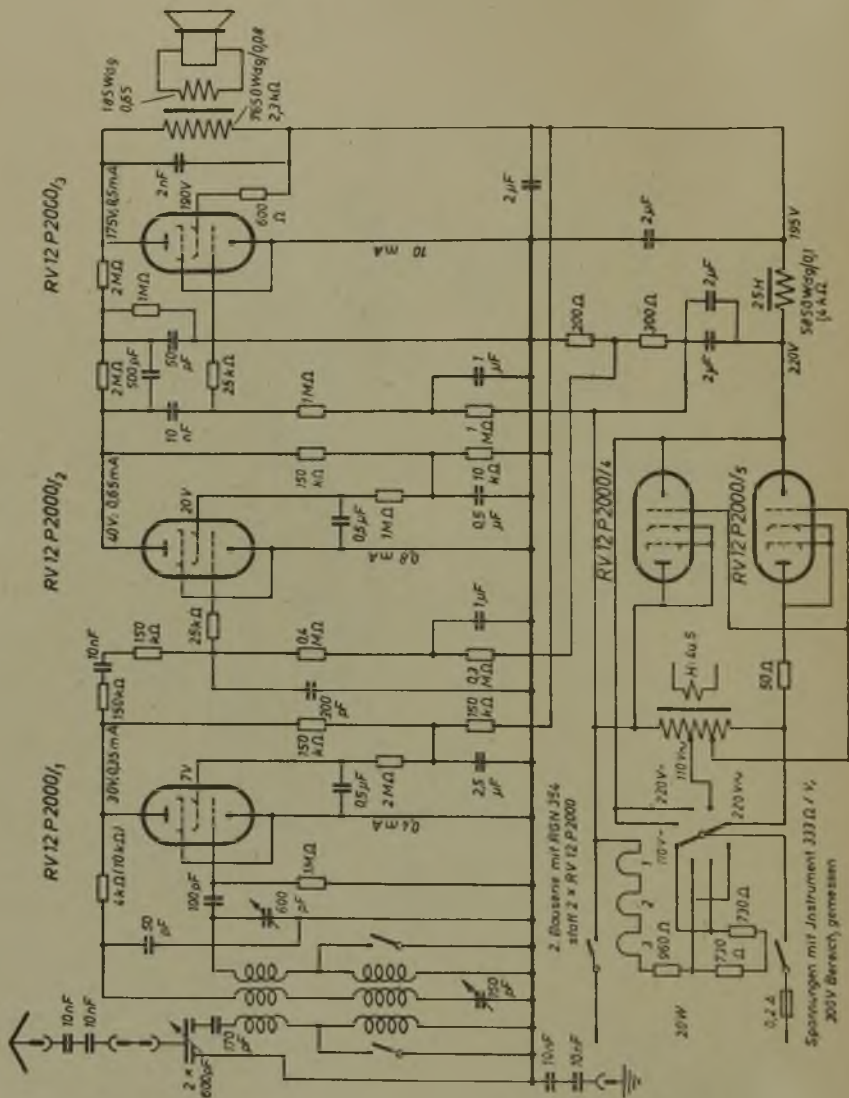

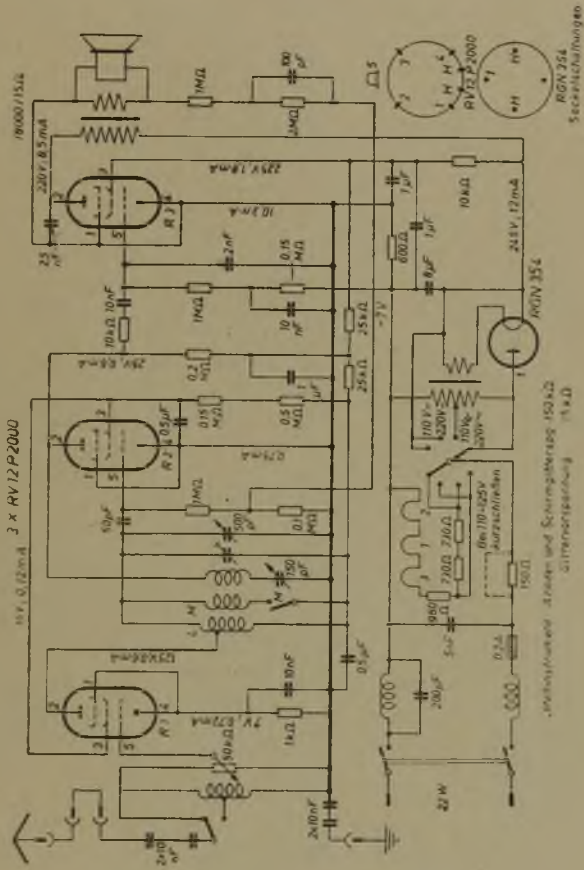

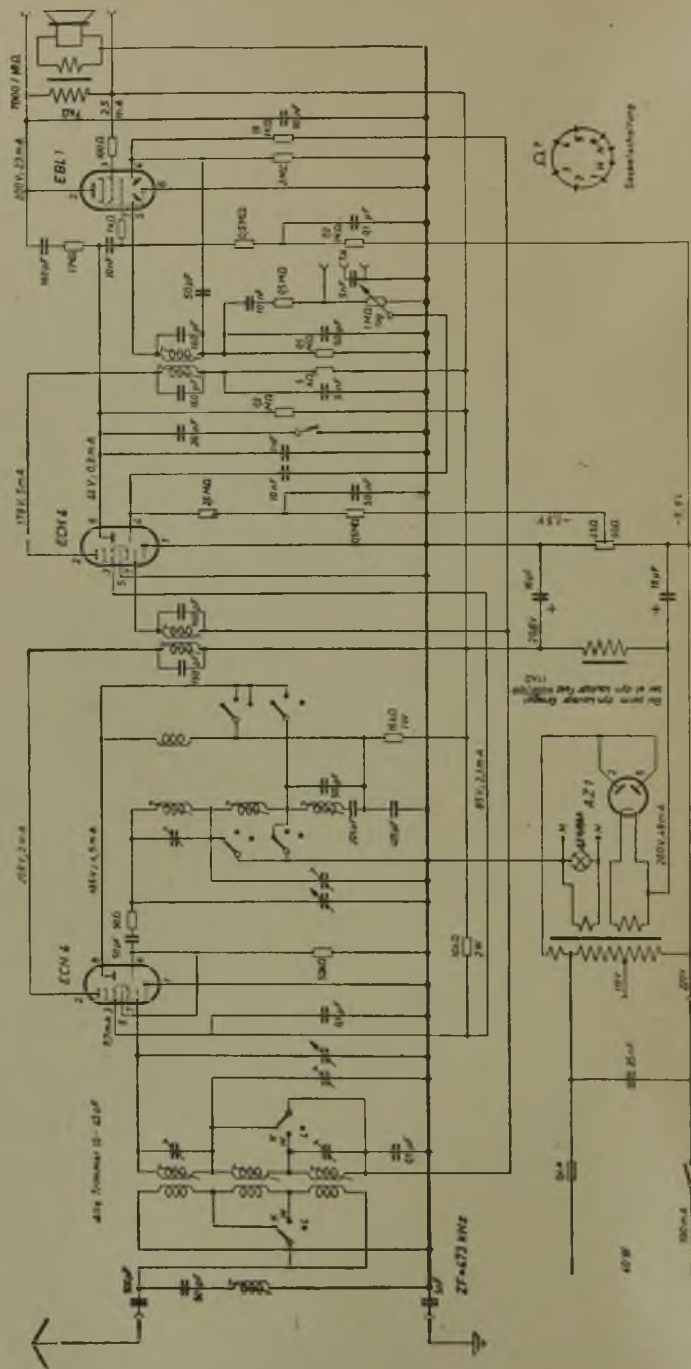

Siemens UKW-Antennenumsetzer SAV 306 W

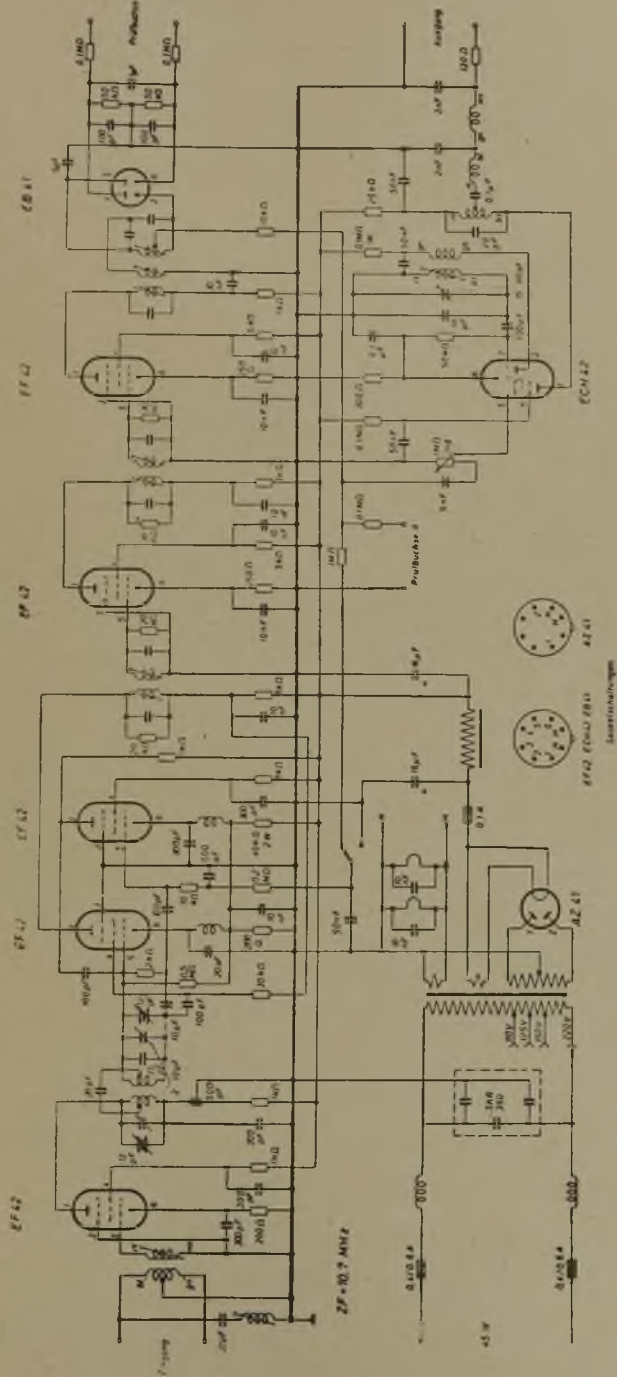

SIEMENS

(Produktion vor 1945)

Siemens Kammermusikgerät I und 545 W

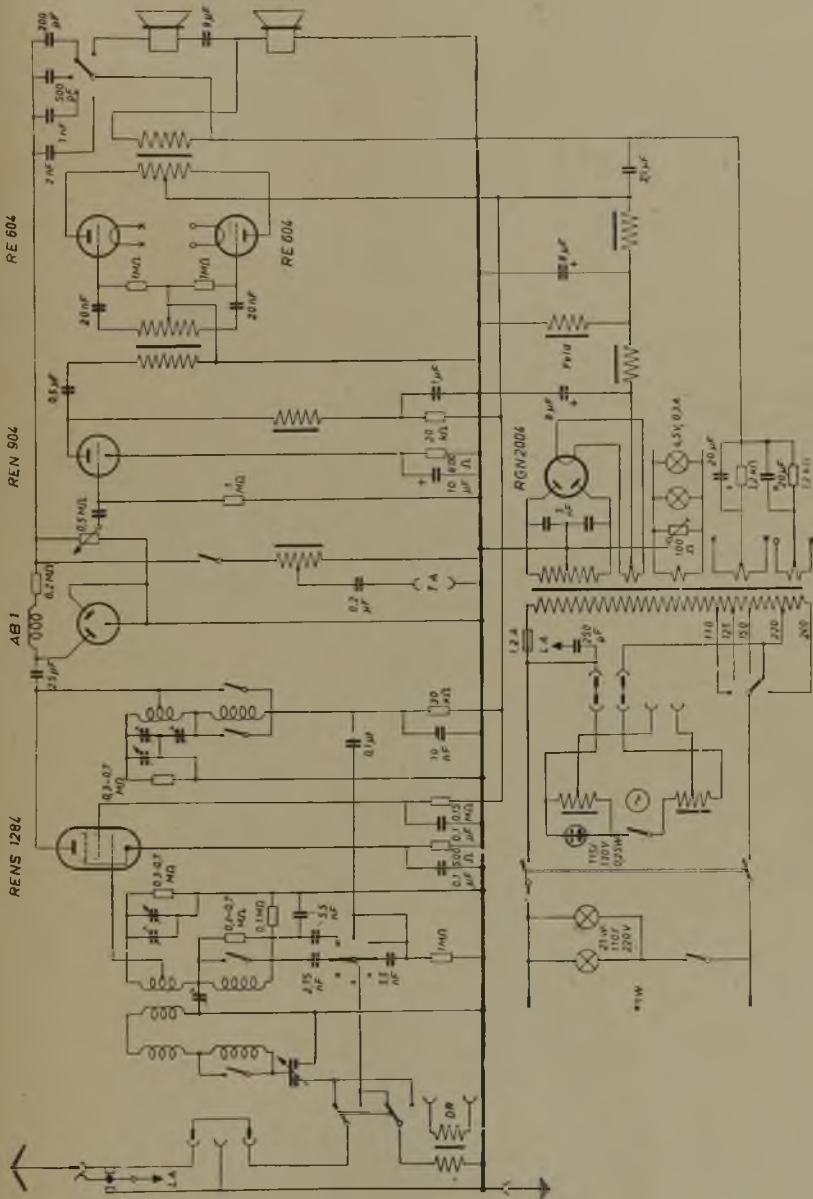

Siemens Kammermusikgerät II

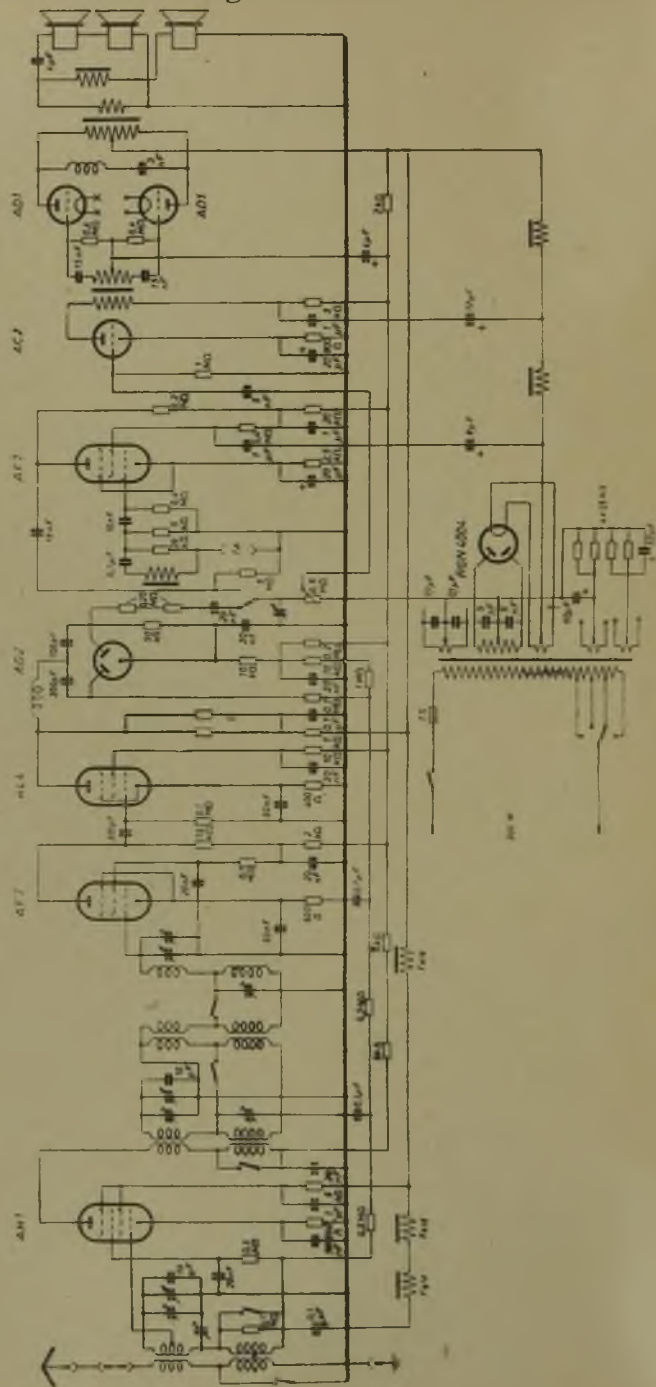

Siemens Kammermusikgerät III

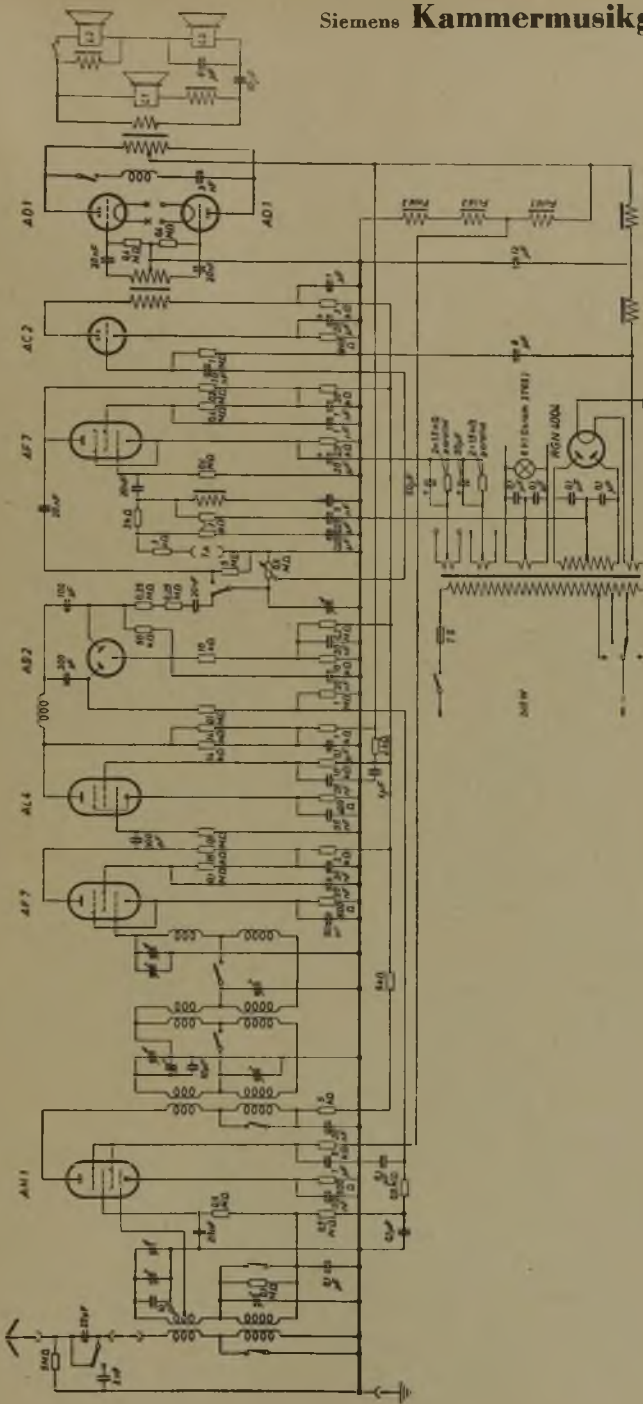

Siemens **Kammermusikgerät IV** (Serie A)
 (linke Seite des Schaltbildes)

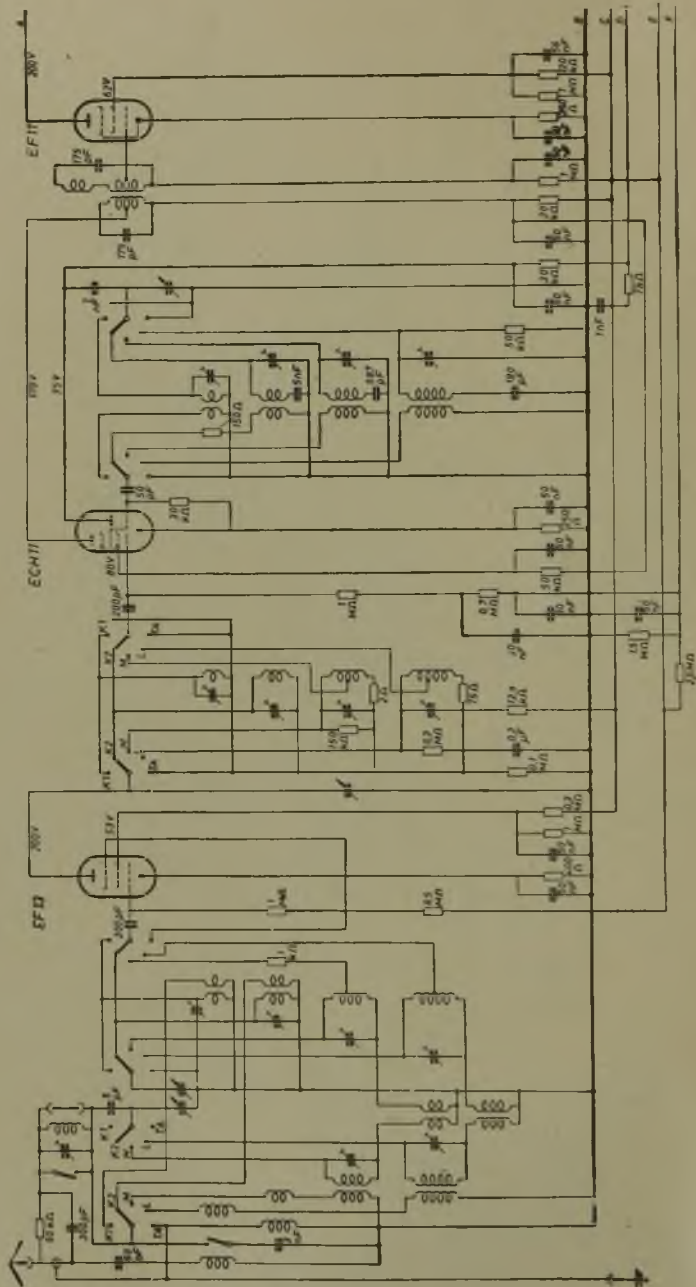

ZF-468 MHz

Siemens **Kammermusikgerät IV** (Serie A)
 (rechte Seite des Schaltbildes)

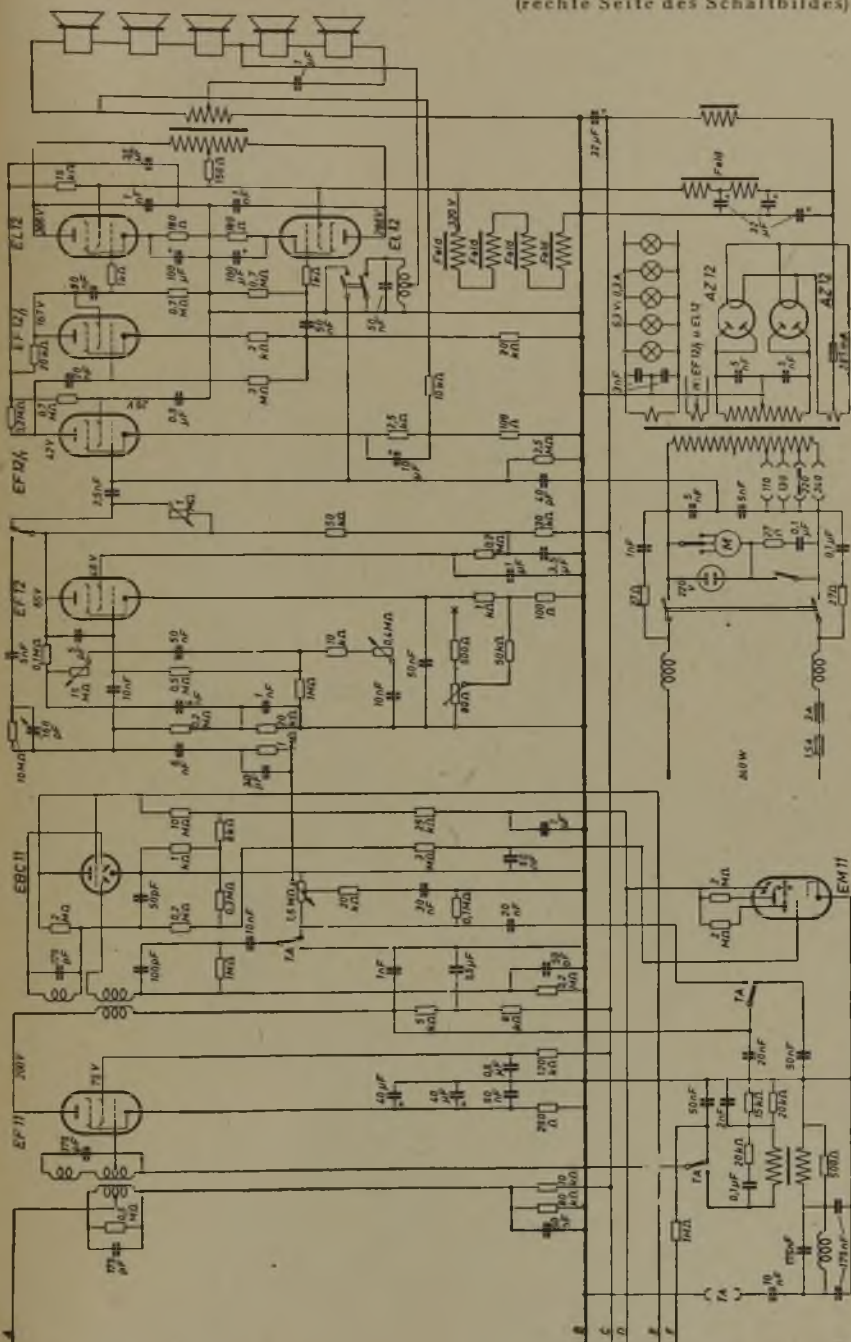

Siemens **Kammermusikgerät IV** (Serie B)
 (linke Seite des Schaltbildes)

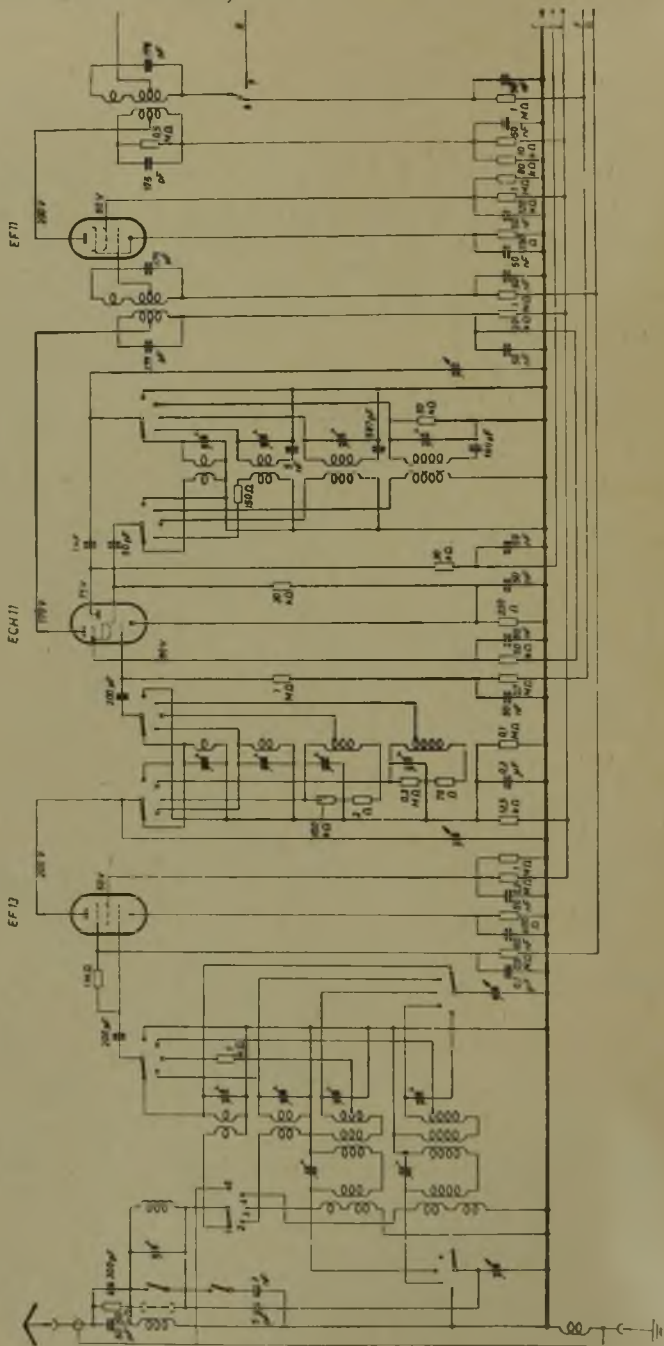

Siemens **Kammermusikgerät IV** (Serie B)
 (rechte Seite des Schaltbildes)

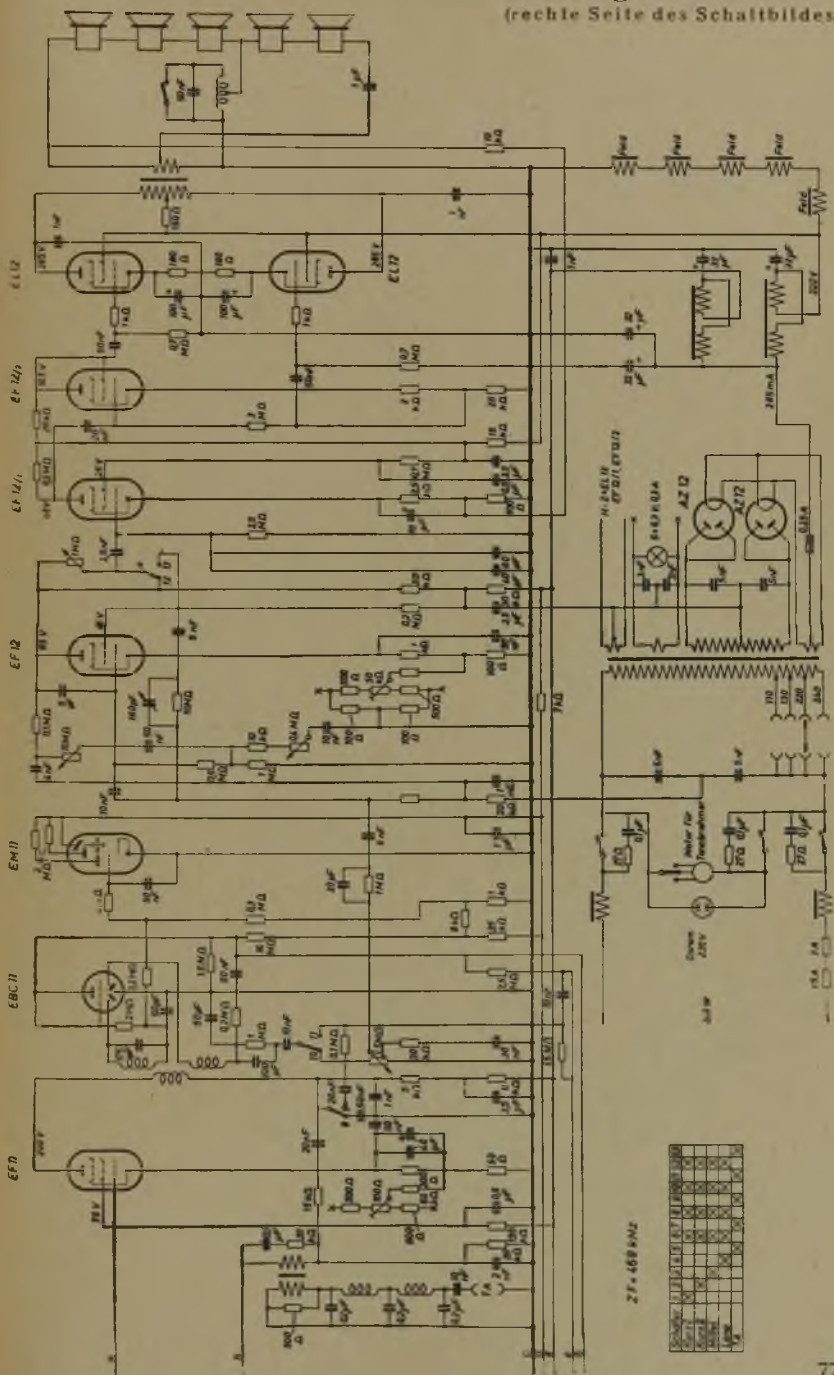

27 = 488 kHz

1	2	3	4	5	6	7	8	9	10	11	12	13	14	15	16	17	18	19	20	21	22	23	24	25	26	27	28	29	30	31	32	33	34	35	36	37	38	39	40	41	42	43	44	45	46	47	48	49	50	51	52	53	54	55	56	57	58	59	60	61	62	63	64	65	66	67	68	69	70	71	72	73	74	75	76	77	78	79	80	81	82	83	84	85	86	87	88	89	90	91	92	93	94	95	96	97	98	99	100
---	---	---	---	---	---	---	---	---	----	----	----	----	----	----	----	----	----	----	----	----	----	----	----	----	----	----	----	----	----	----	----	----	----	----	----	----	----	----	----	----	----	----	----	----	----	----	----	----	----	----	----	----	----	----	----	----	----	----	----	----	----	----	----	----	----	----	----	----	----	----	----	----	----	----	----	----	----	----	----	----	----	----	----	----	----	----	----	----	----	----	----	----	----	----	----	----	----	----	-----

Siemens Standard 3 Röhren GW

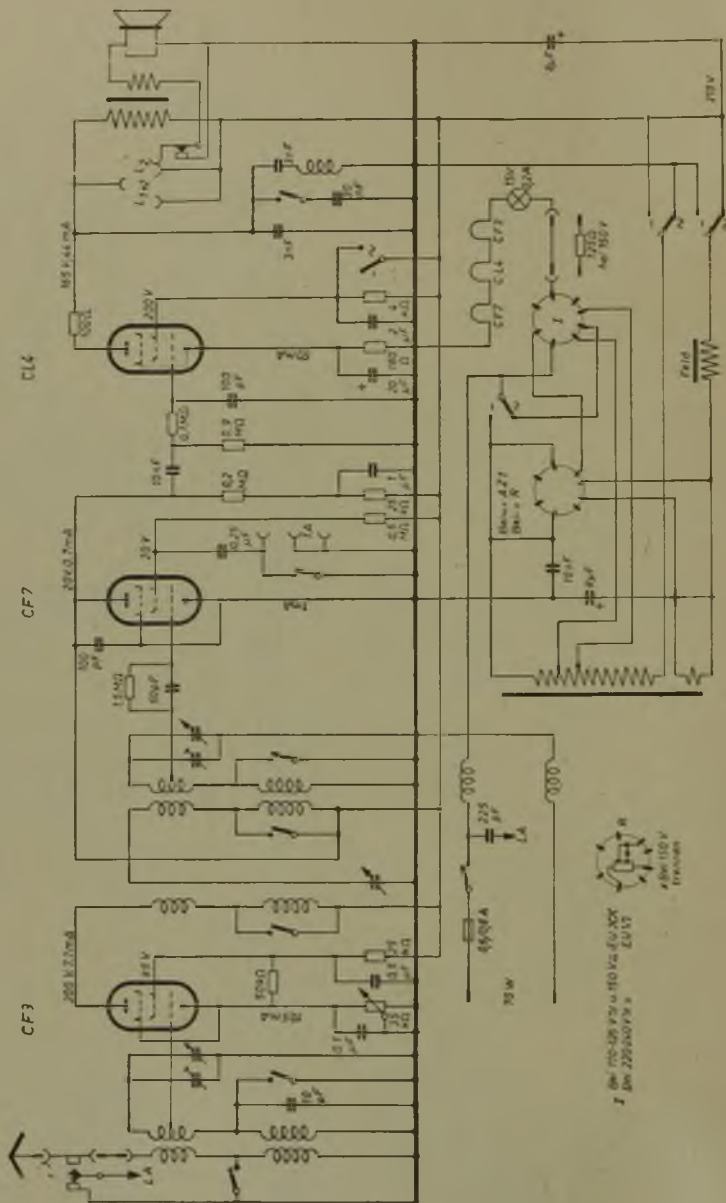

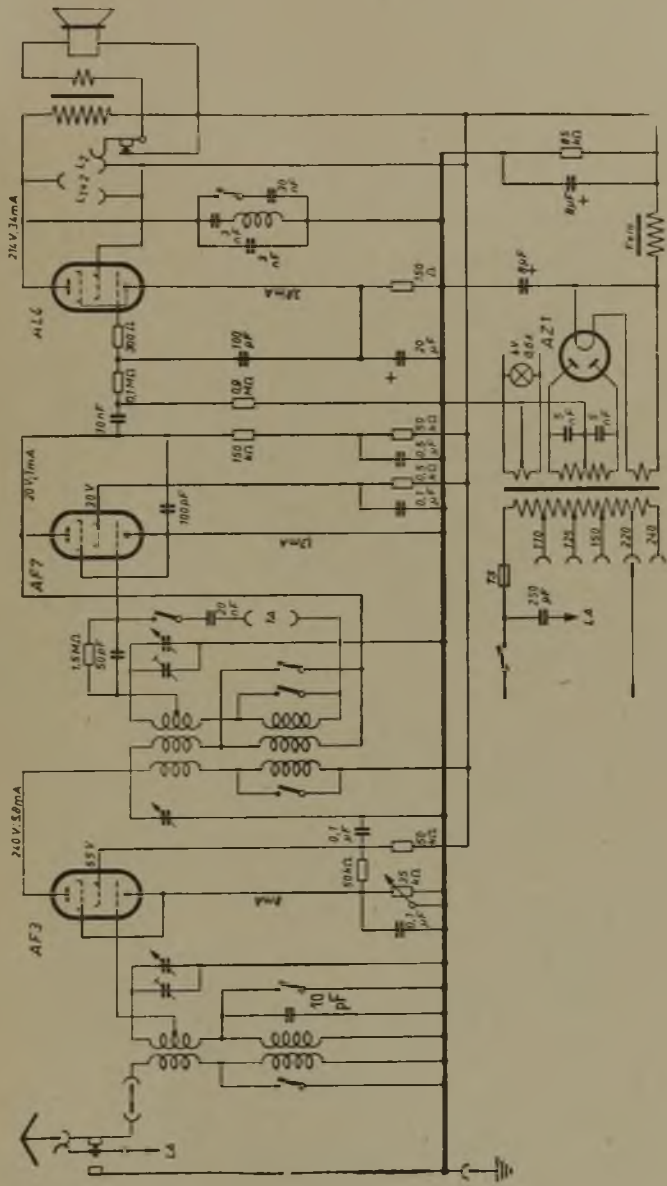

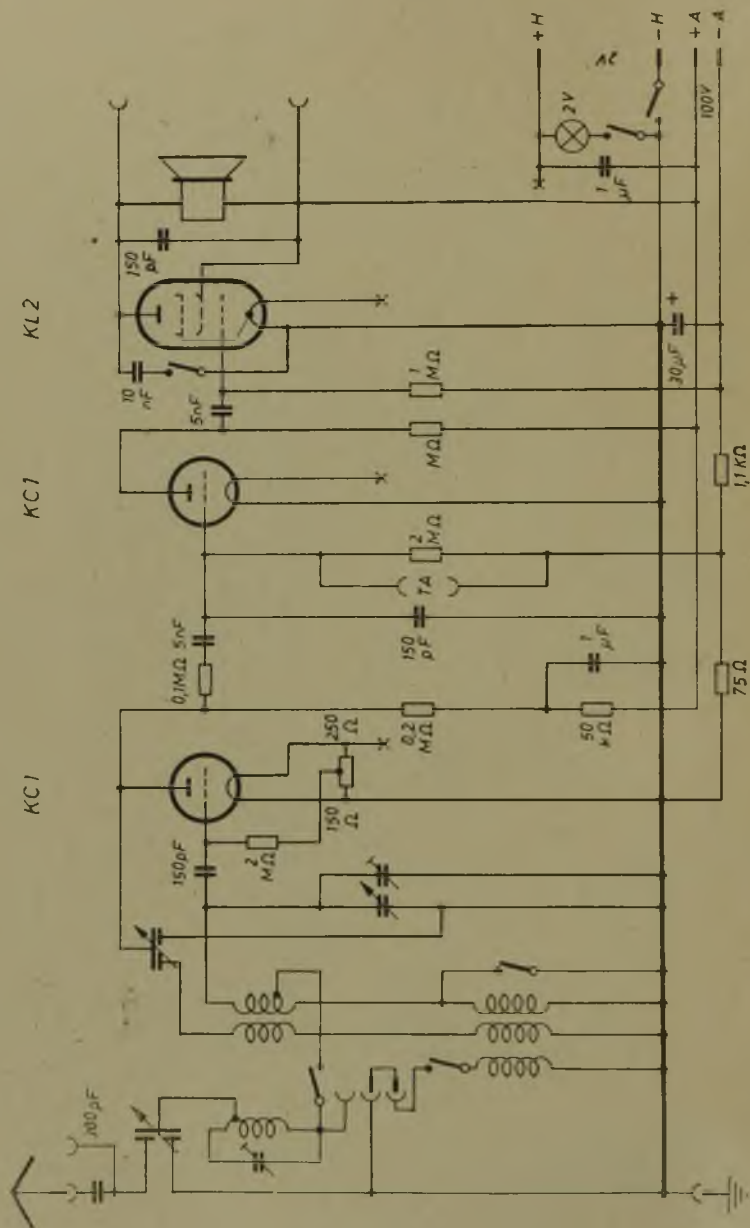

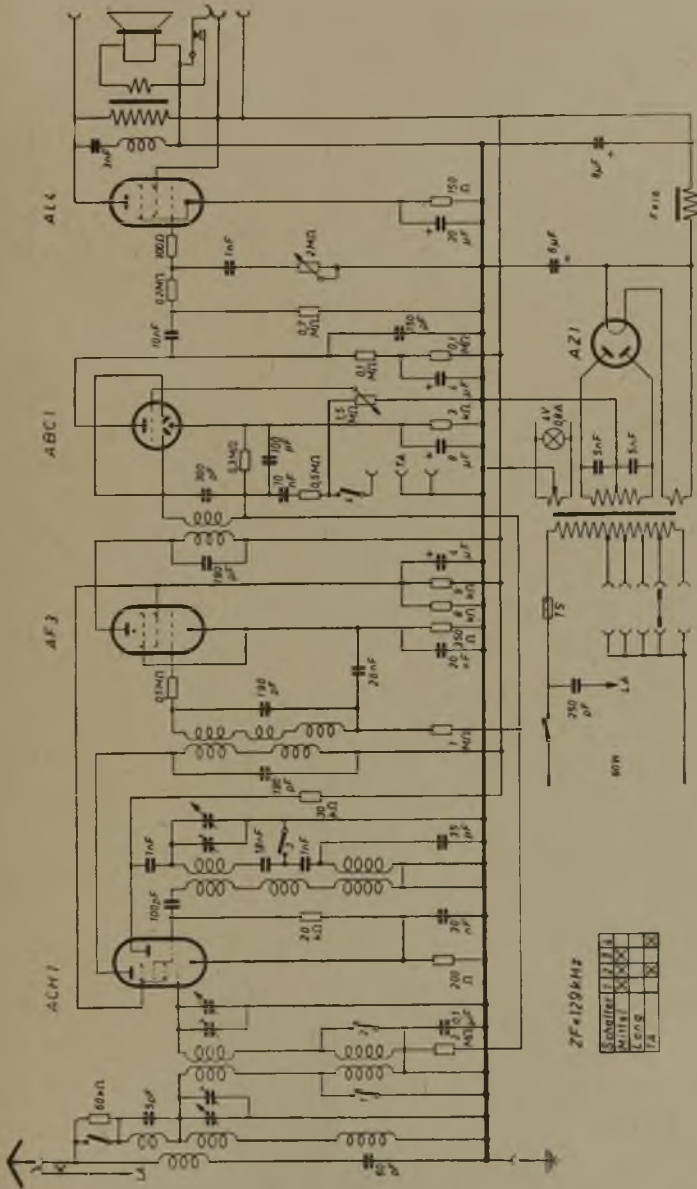

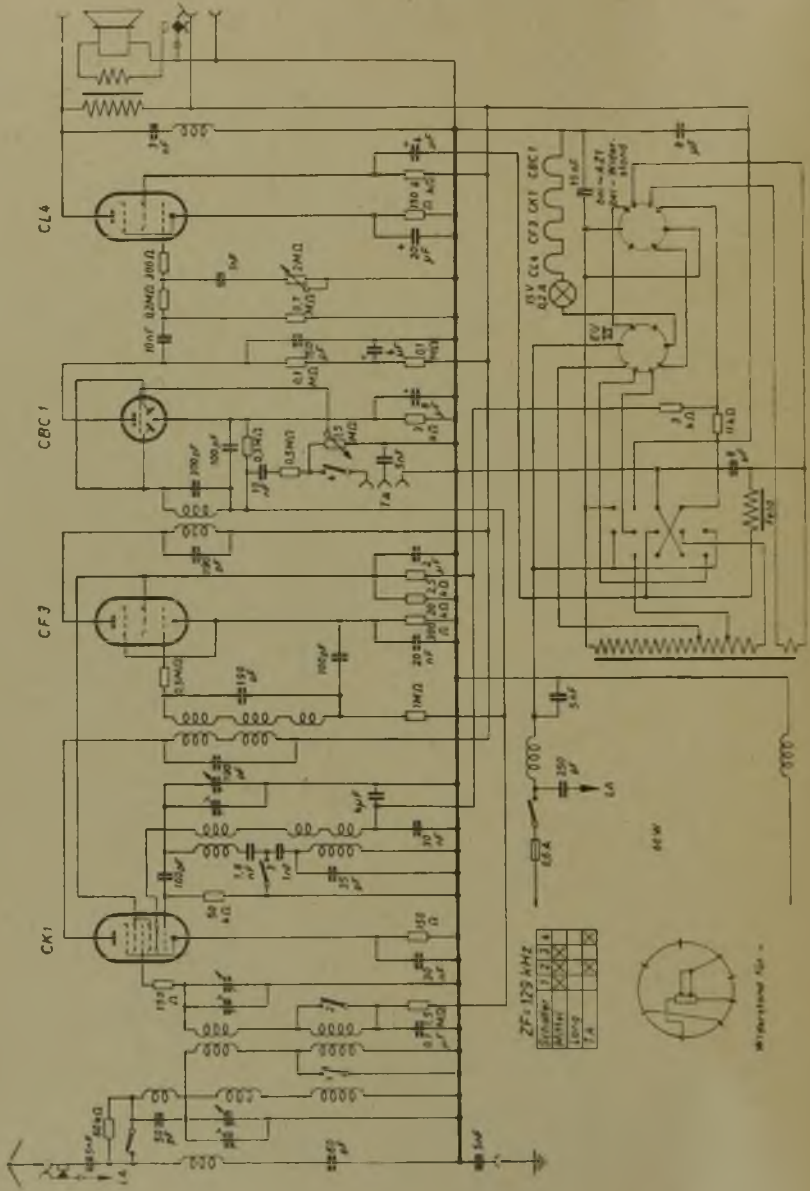

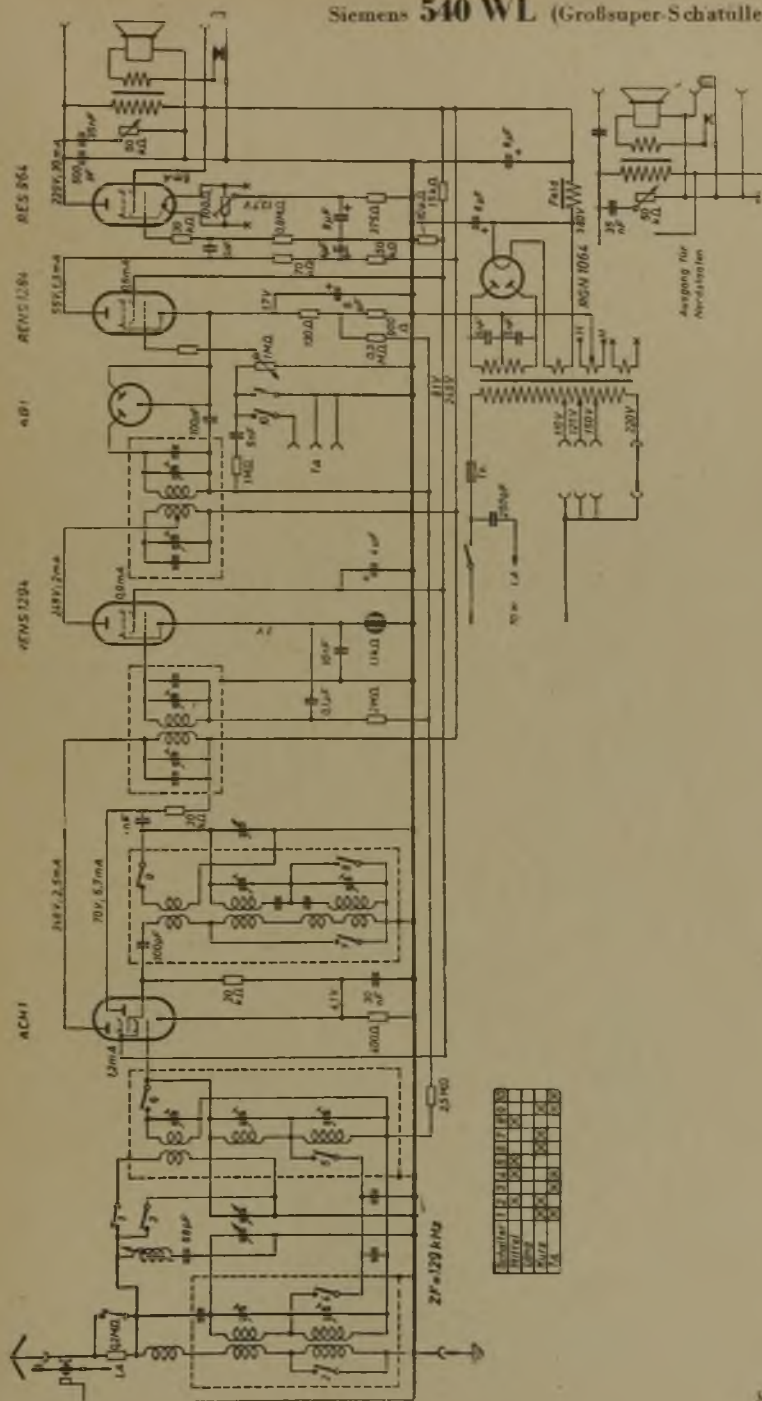

Siemens 540 GW (Großsuper-Schaltulle)

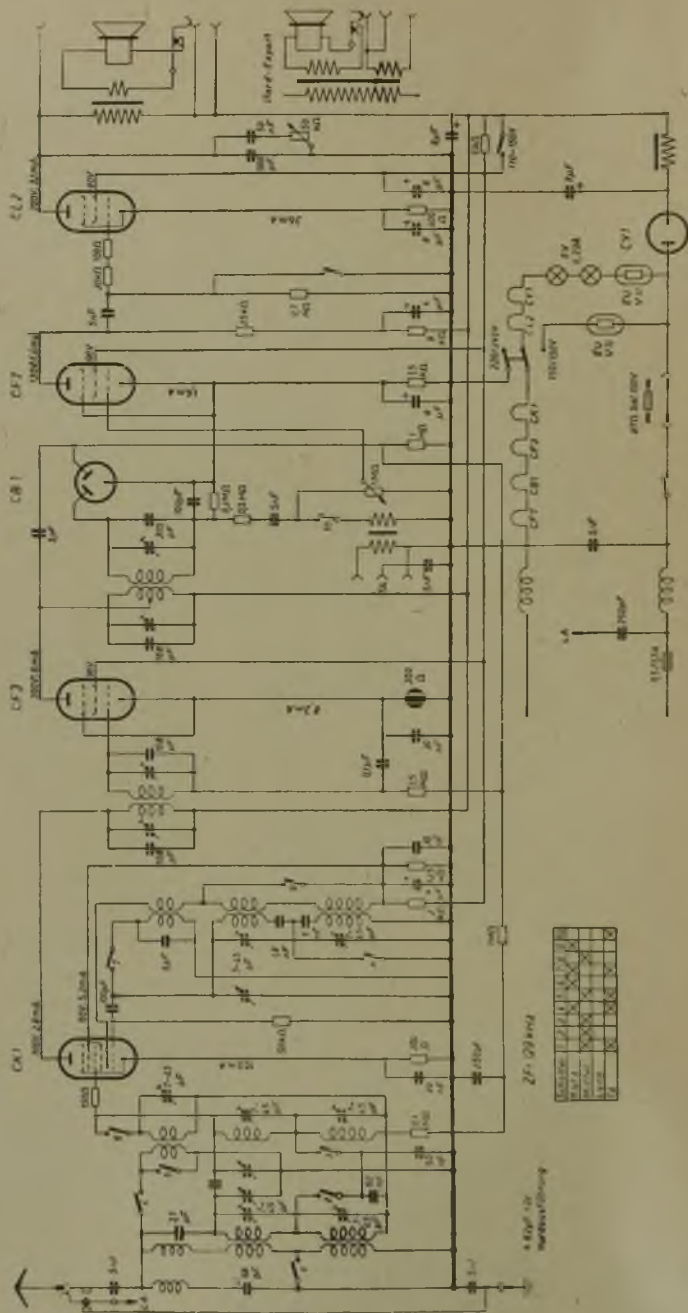

Symbol	Value
⊗	1000
⊙	100
⊚	10
⊛	1
⊜	0.1
⊝	0.01
⊞	0.001
⊟	0.0001
⊠	0.00001
⊡	0.000001
⊢	0.0000001
⊣	0.00000001
⊤	0.000000001
⊥	0.0000000001
⊦	0.00000000001
⊧	0.000000000001
⊨	0.0000000000001
⊩	0.00000000000001
⊪	0.000000000000001
⊫	0.0000000000000001
⊬	0.00000000000000001
⊭	0.000000000000000001
⊮	0.0000000000000000001
⊯	0.00000000000000000001
⊰	0.000000000000000000001
⊱	0.0000000000000000000001
⊲	0.00000000000000000000001
⊳	0.000000000000000000000001
⊴	0.0000000000000000000000001
⊵	0.00000000000000000000000001
⊶	0.000000000000000000000000001
⊷	0.0000000000000000000000000001
⊸	0.00000000000000000000000000001
⊹	0.000000000000000000000000000001
⊺	0.0000000000000000000000000000001
⊻	0.00000000000000000000000000000001
⊼	0.000000000000000000000000000000001
⊽	0.0000000000000000000000000000000001
⊾	0.00000000000000000000000000000000001
⊿	0.000000000000000000000000000000000001
⊠	0.0000000000000000000000000000000000001
⊡	0.00000000000000000000000000000000000001
⊢	0.000000000000000000000000000000000000001
⊣	0.0000000000000000000000000000000000000001
⊤	0.001
⊥	0.0001
⊦	0.001
⊧	0.0001
⊨	0.001
⊩	0.0001
⊪	0.001
⊫	0.0001
⊬	0.001
⊭	0.0001
⊮	0.001
⊯	0.0001
⊰	0.001
⊱	0.0001
⊲	0.001
⊳	0.0001
⊴	0.001
⊵	0.0001
⊶	0.001
⊷	0.0001
⊸	0.001
⊹	0.0001
⊺	0.001
⊻	0.0001
⊼	0.001
⊽	0.0001
⊾	0.001
⊿	0.0001

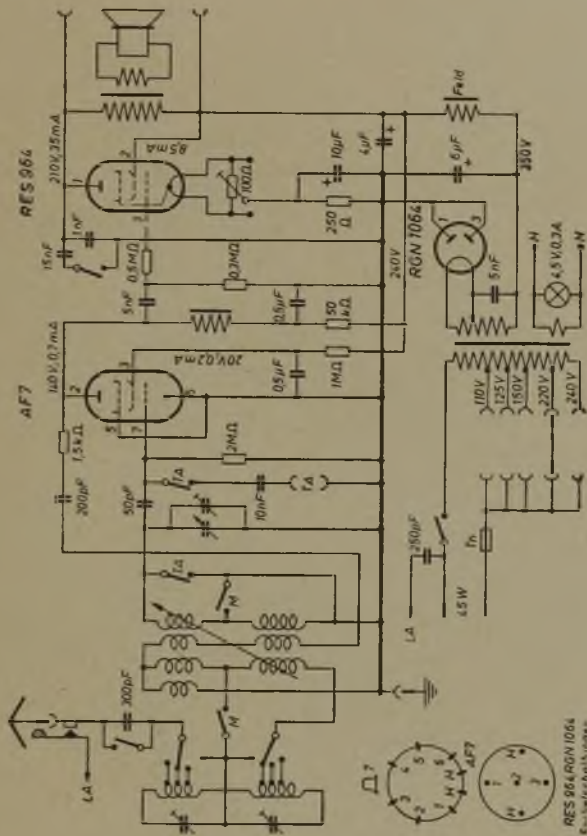

RES 964 RGN 1064
Siemensradio

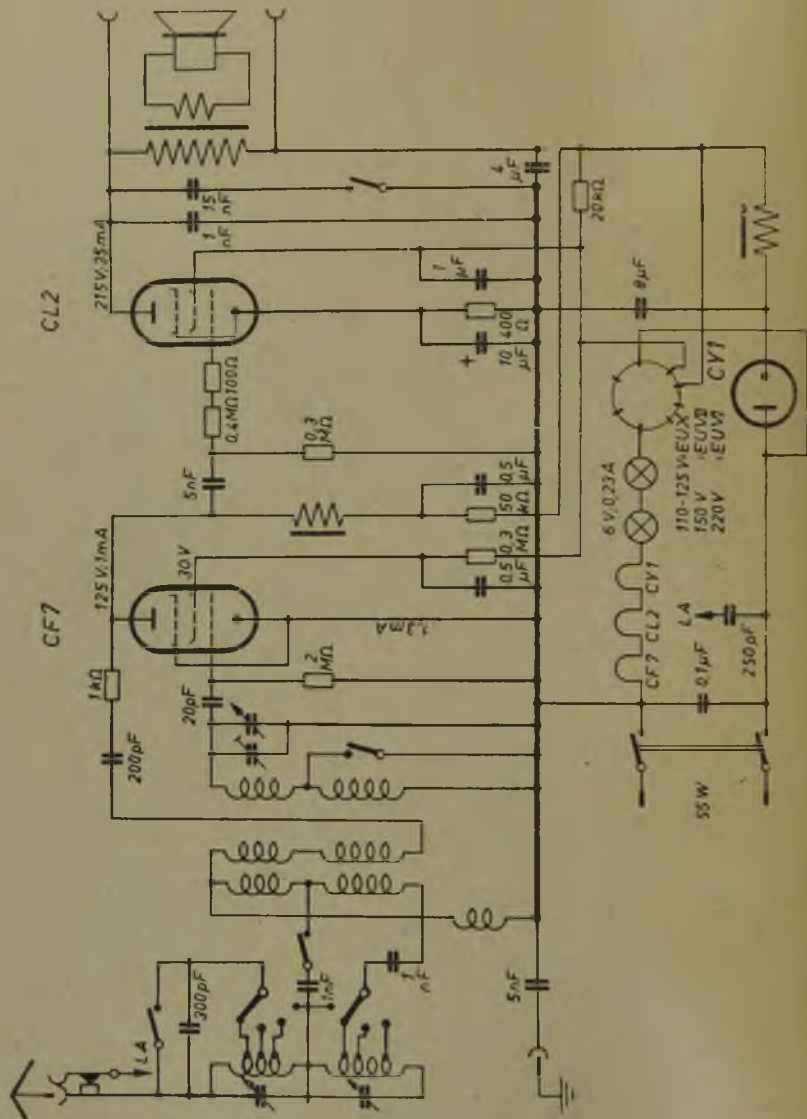

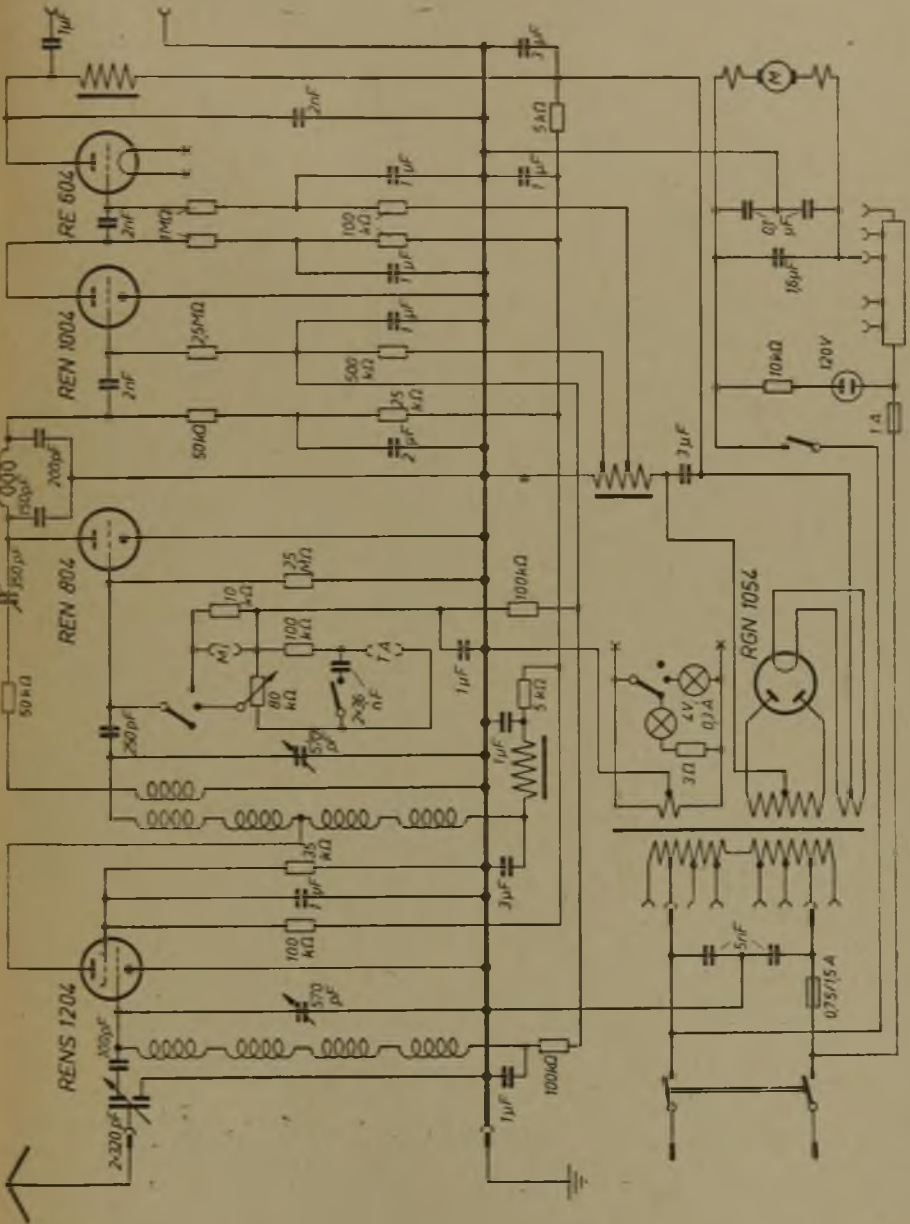

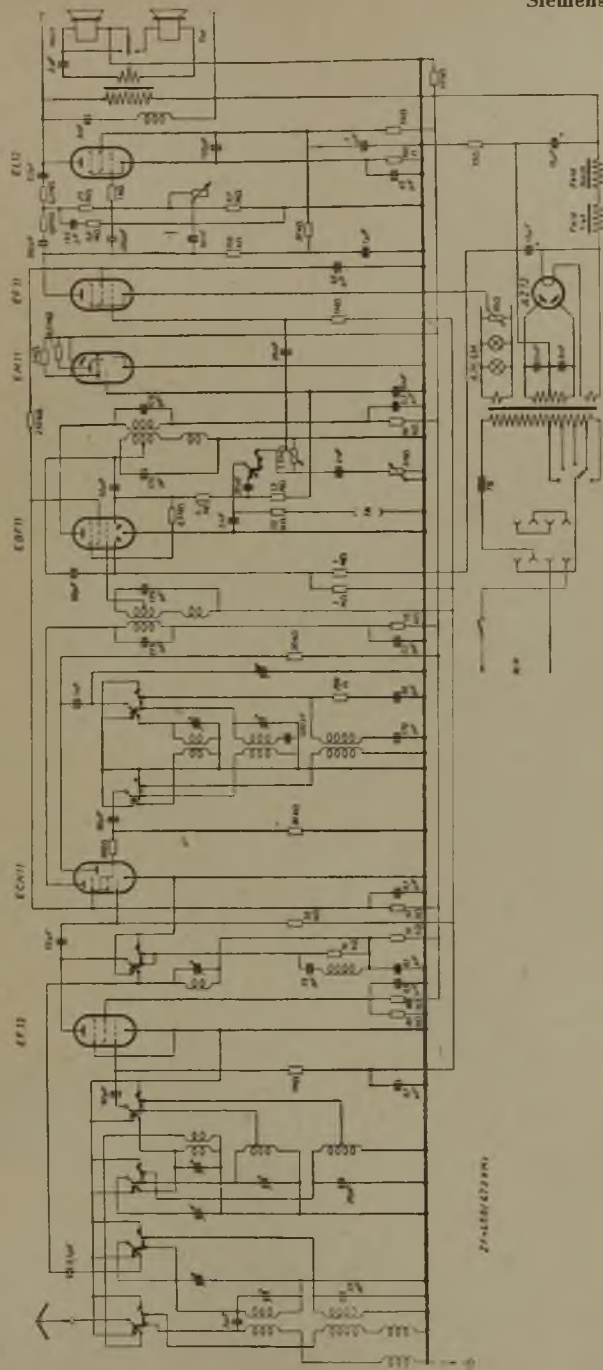

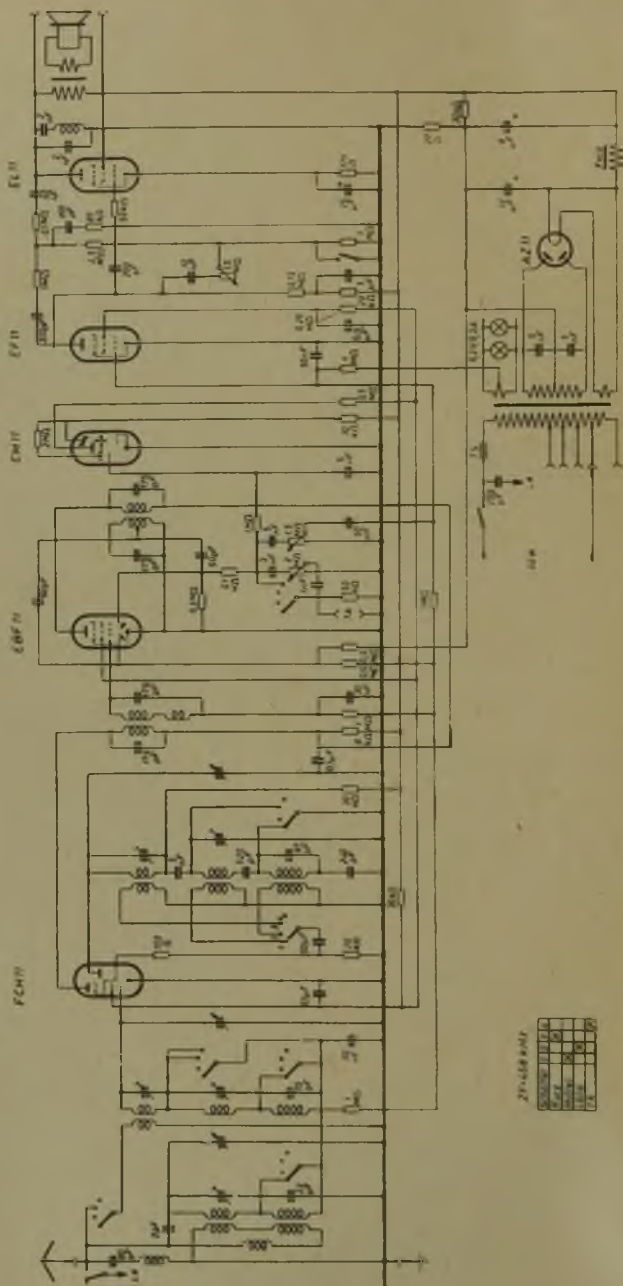

27-458-101

1	2	3	4	5	6	7	8	9	10
11	12	13	14	15	16	17	18	19	20
21	22	23	24	25	26	27	28	29	30
31	32	33	34	35	36	37	38	39	40

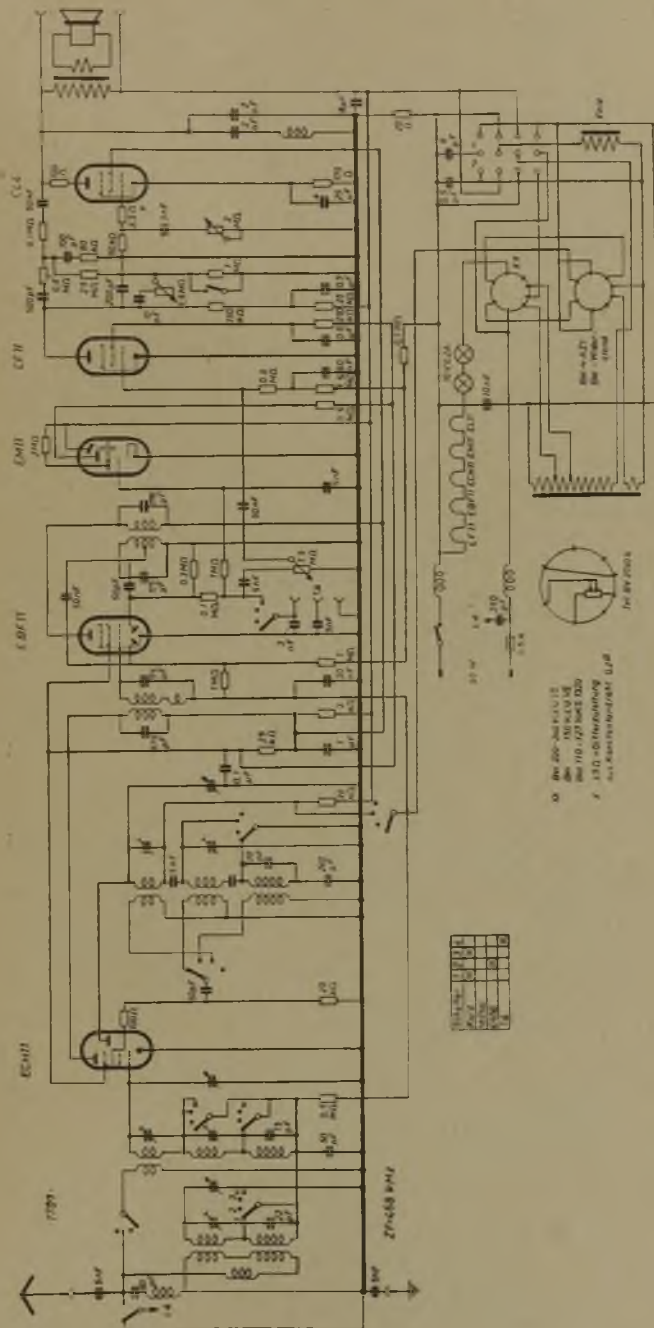

Siemens 93 WK

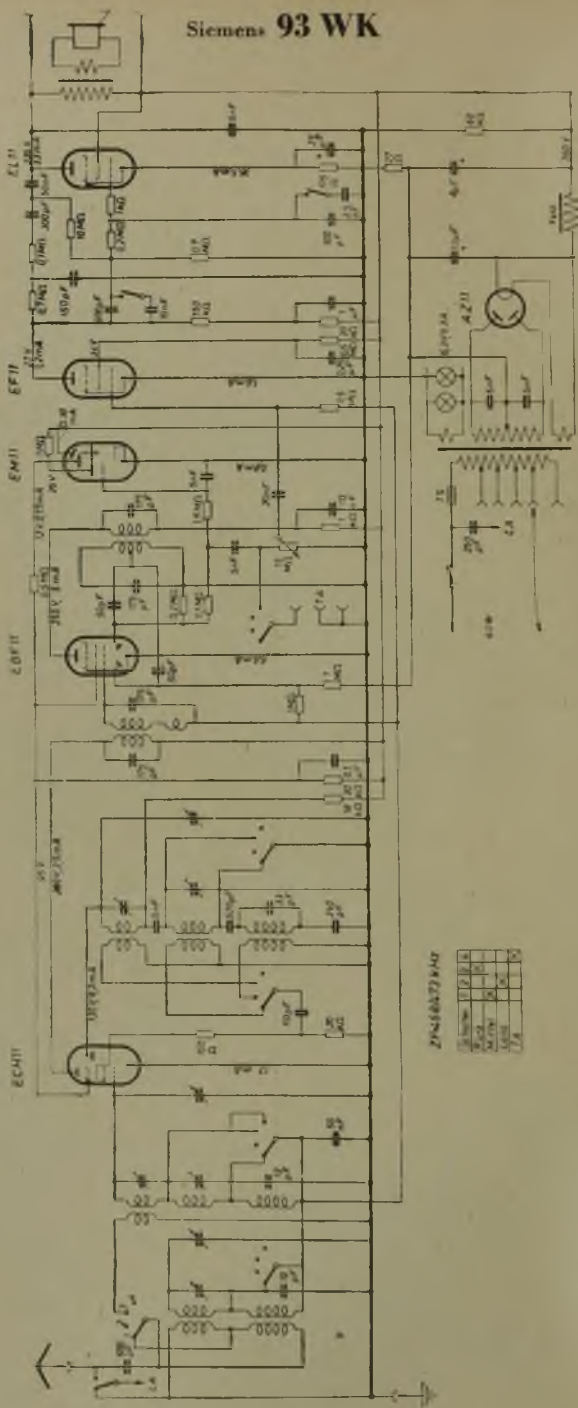

ZFN 56729/42

Typ	1	2	3	4	5
W					
U					
A					

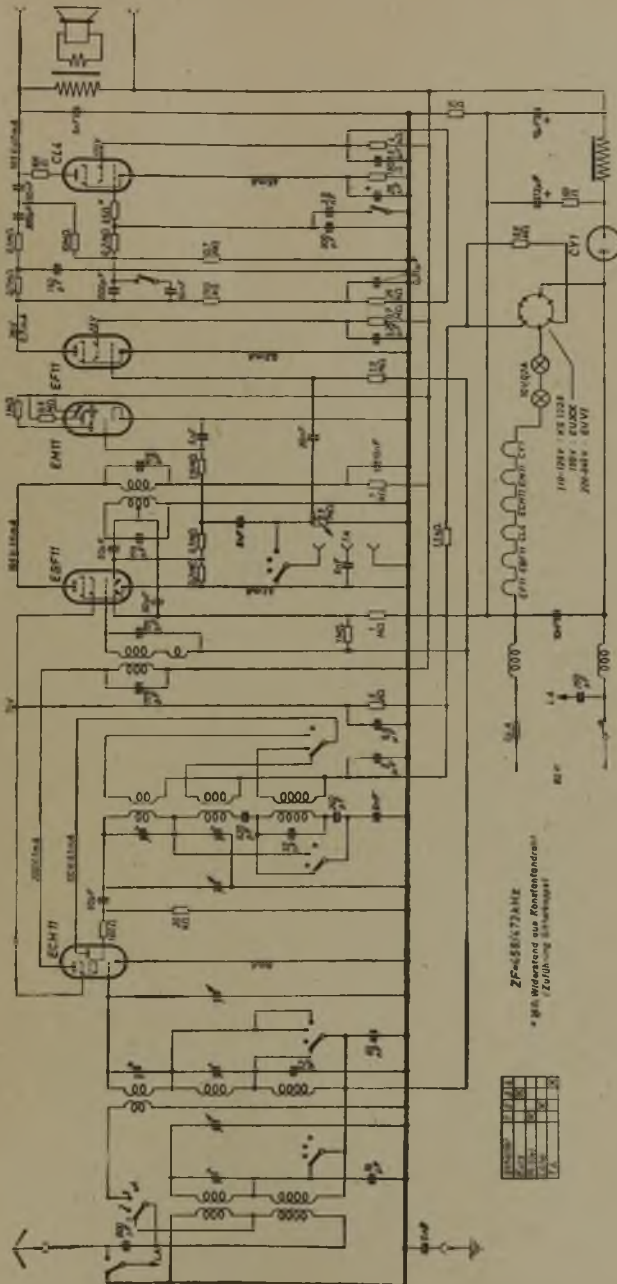

ZP-6581672A/B
 * gilt Widerstand aus Konzentrenz
 (Zurückführung über Schalter)

Gezeichnet					
Überprüft					
Von					
Am					

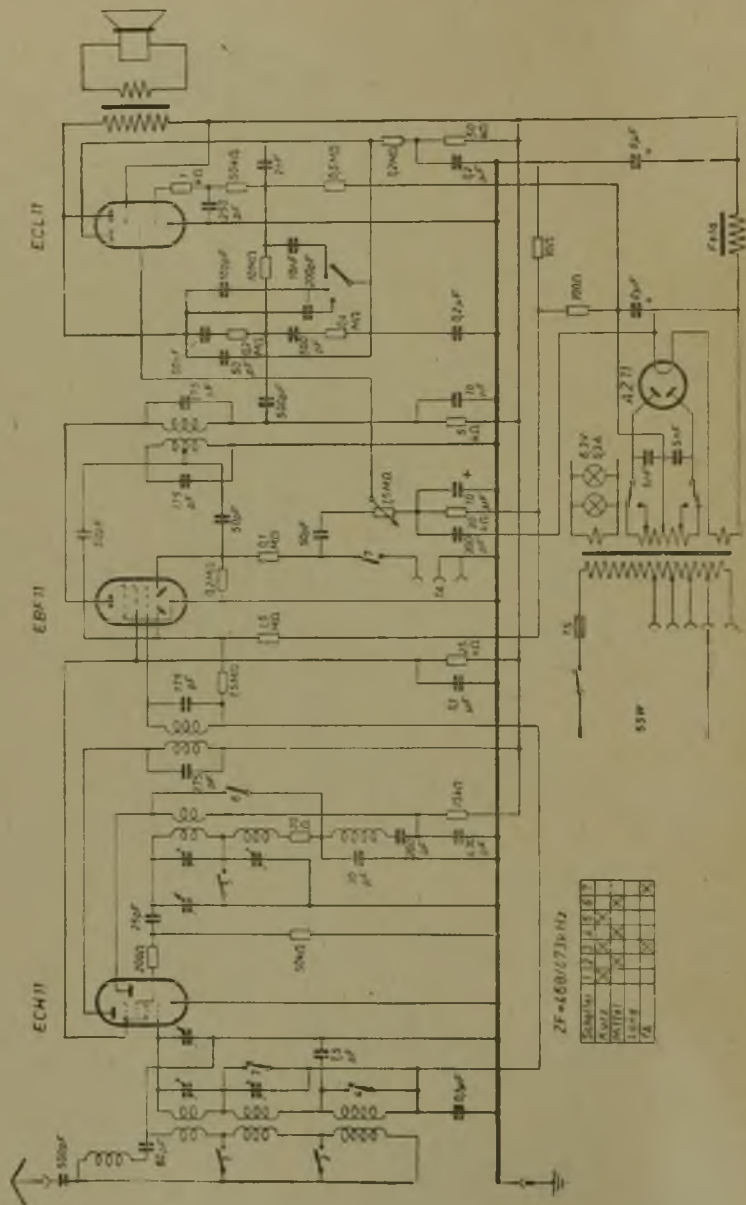

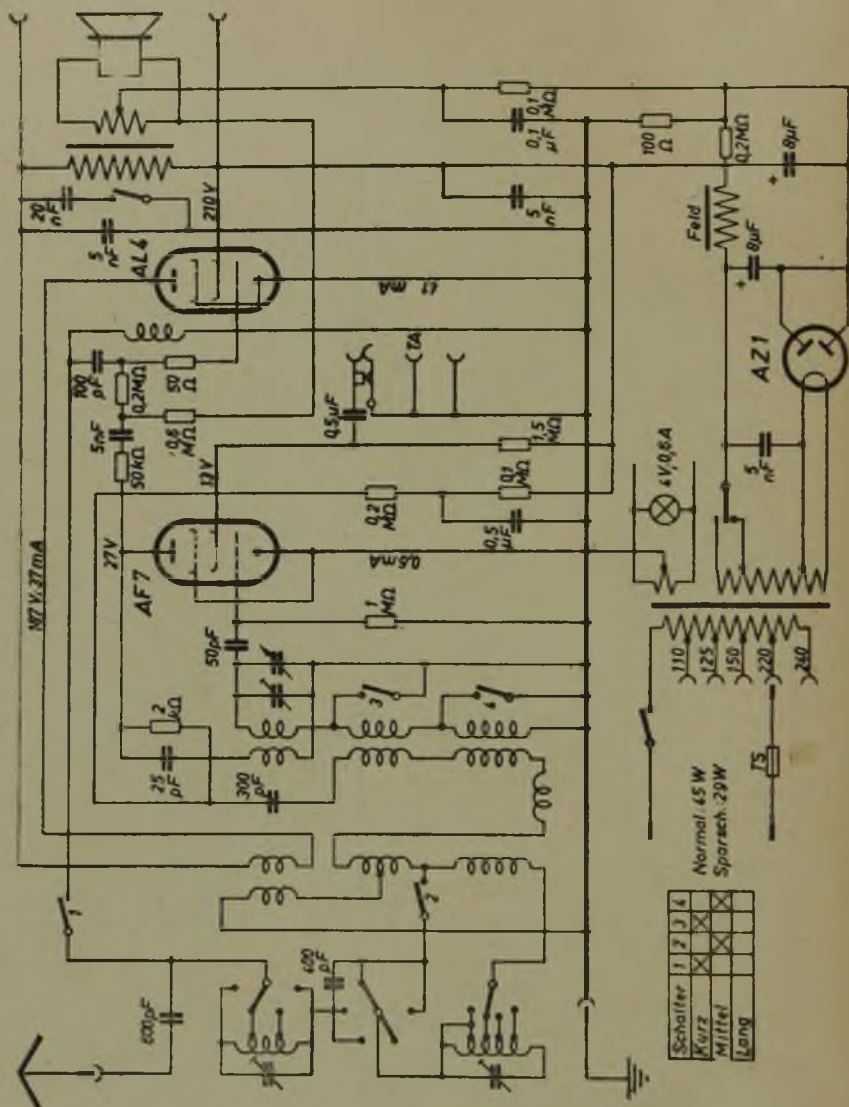

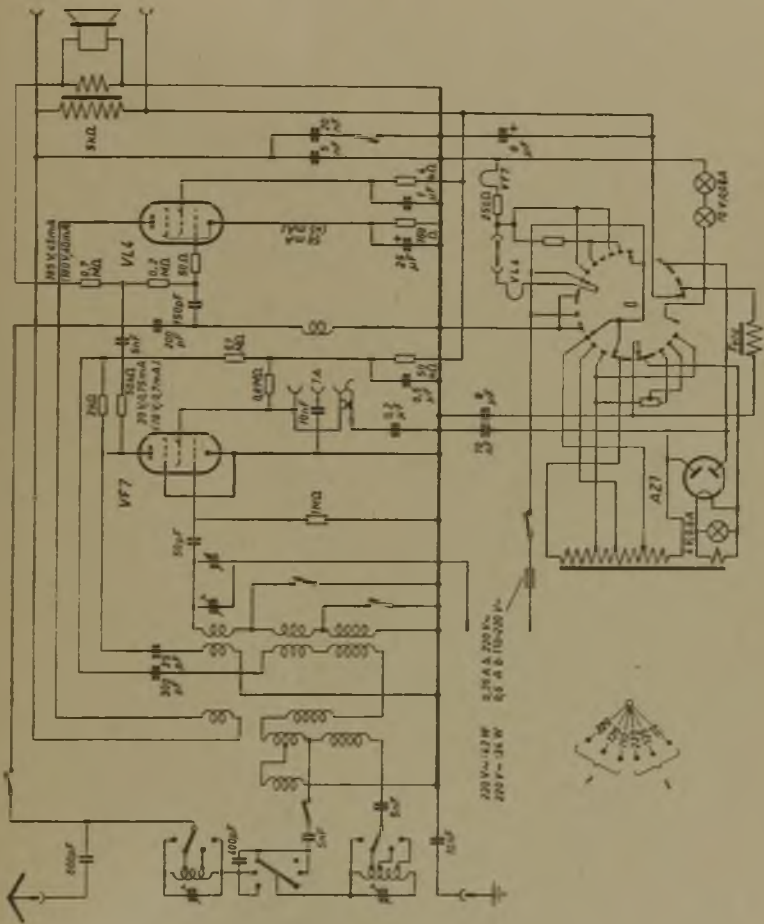

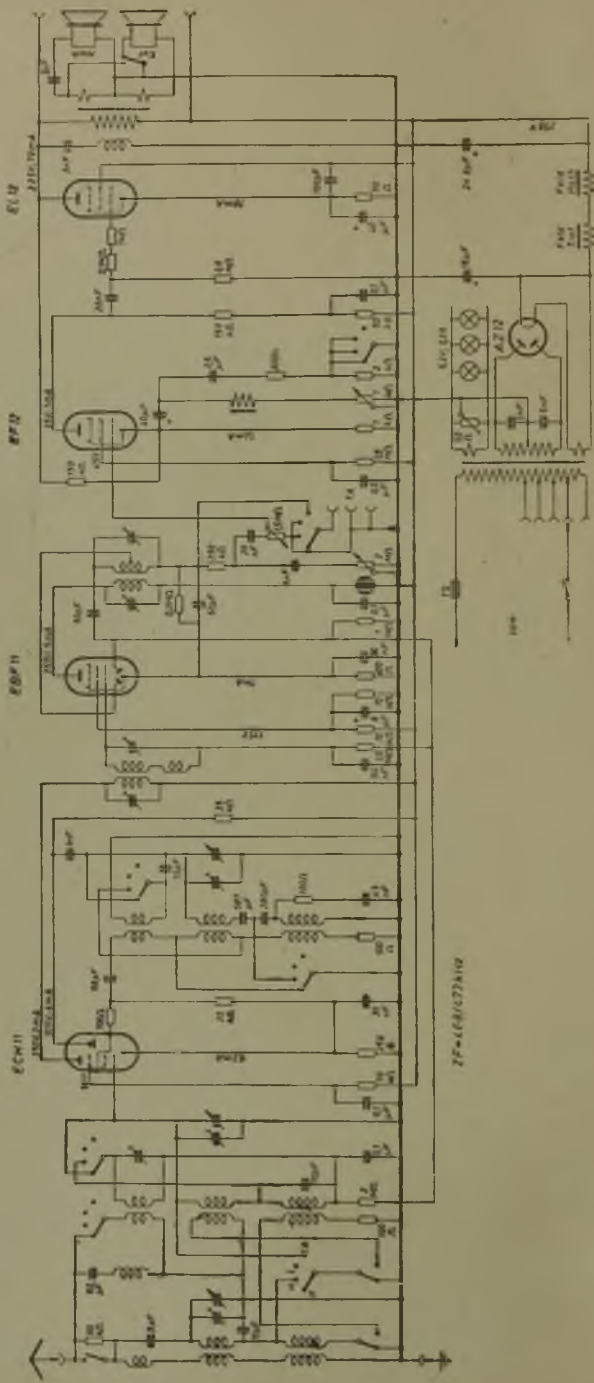

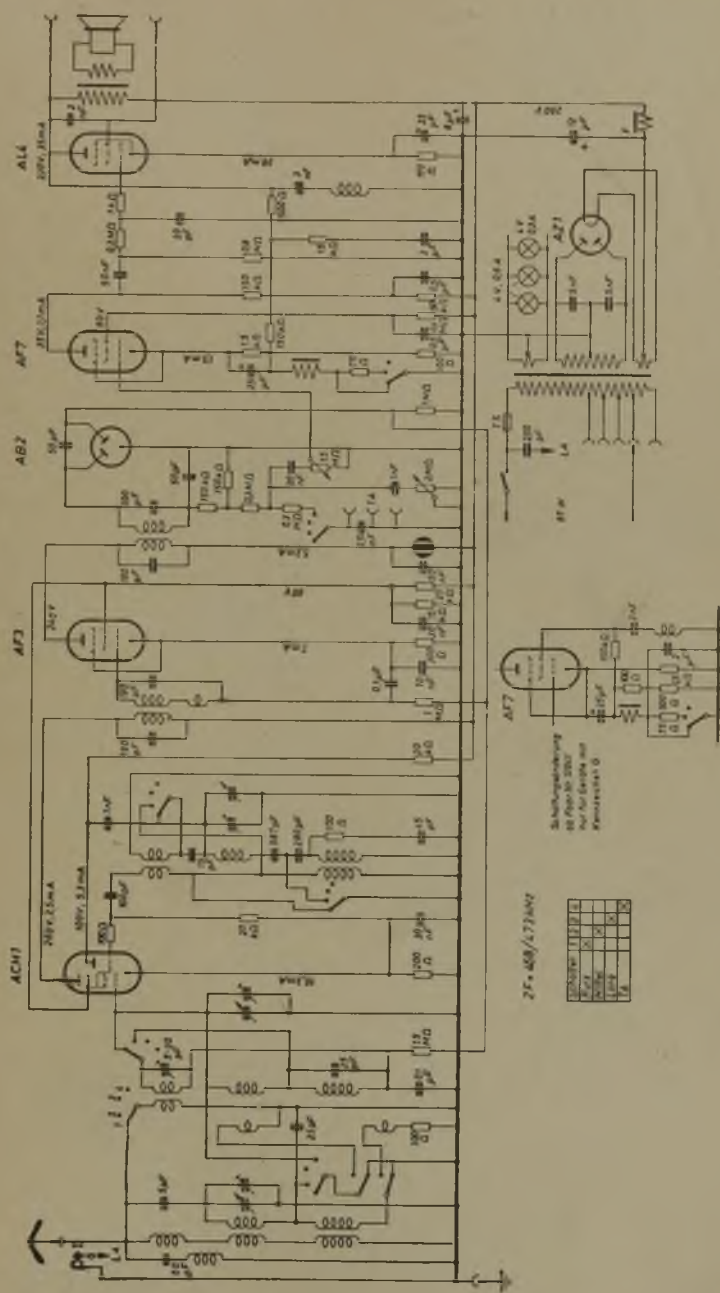

Siemens 84 GW Saturn

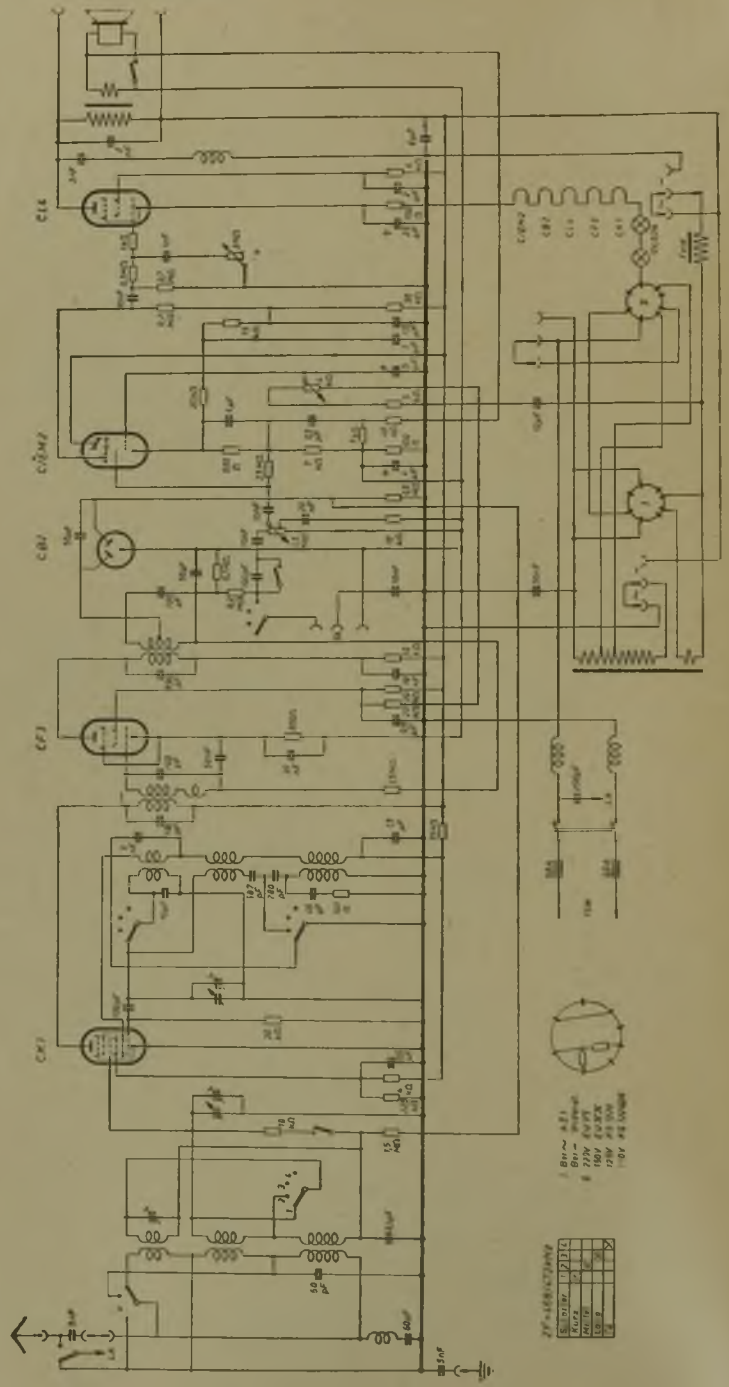

1. 84W ~ 2.1
 2. 84W ~ 2.1
 3. 150V 2.1
 4. 100V 2.1
 5. 100V 2.1

ZF-188122222

1	2	3	4	5
1	2	3	4	5
1	2	3	4	5
1	2	3	4	5
1	2	3	4	5

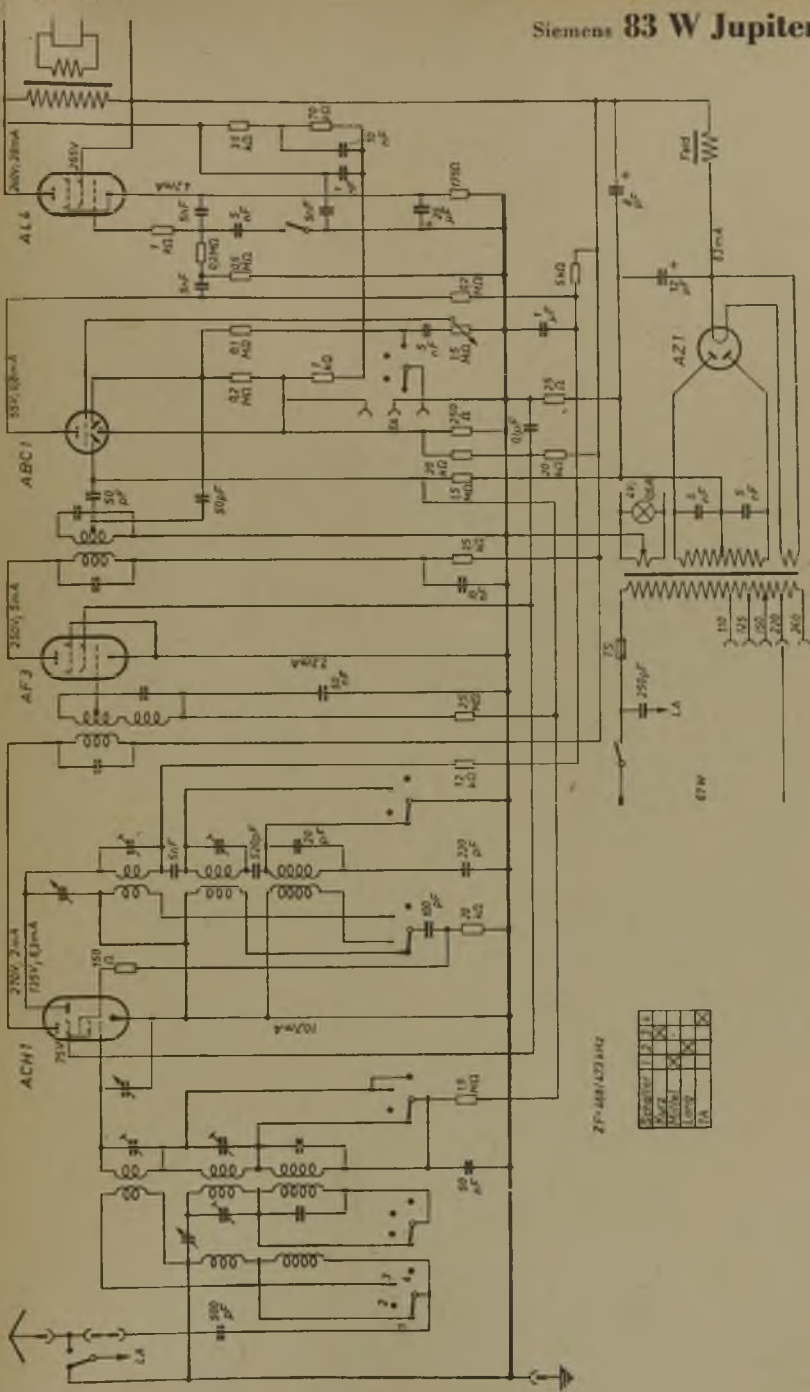

Siemens 83 GW Jupiter

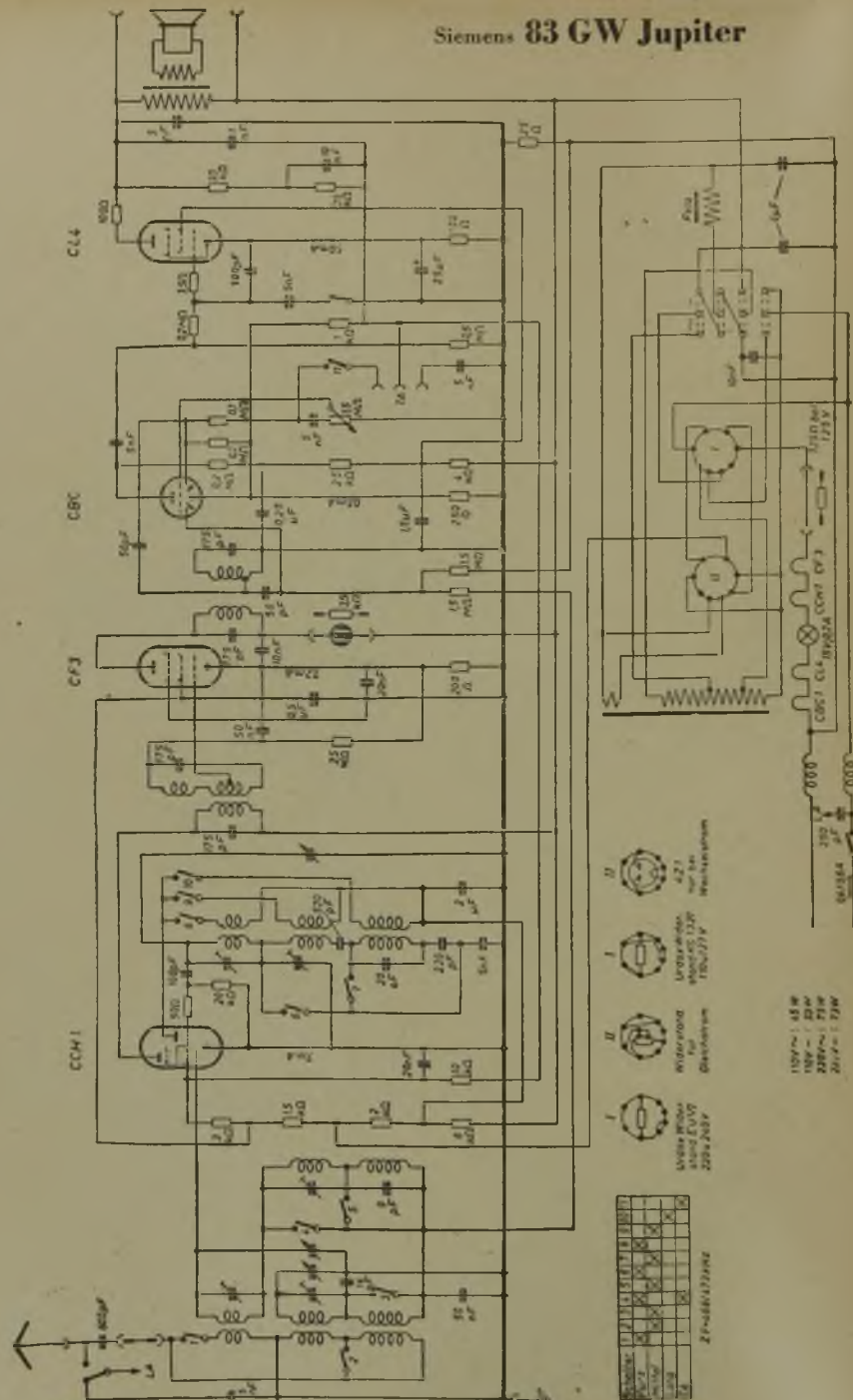

- II** 4.21
Vierkathoden
für 6A5
Rechenröhre
- I** 4.21
Vierkathoden
für 6A5
Rechenröhre
- II** 4.21
Vierkathoden
für 6A5
Rechenröhre
- I** 4.21
Vierkathoden
für 6A5
Rechenröhre

Zeichn.-	1	2	3	4	5	6	7	8	9	10
Widerstand	X	X	X	X	X	X	X	X	X	X
Kapazität	X	X	X	X	X	X	X	X	X	X
Induktivität	X	X	X	X	X	X	X	X	X	X
Elektronen- röhre	X	X	X	X	X	X	X	X	X	X
Relais	X	X	X	X	X	X	X	X	X	X
Schalter	X	X	X	X	X	X	X	X	X	X

ZF-226/1372K

110V ~ : 45 W
125V ~ : 25 W
230V ~ : 75 W
250V ~ : 75 W

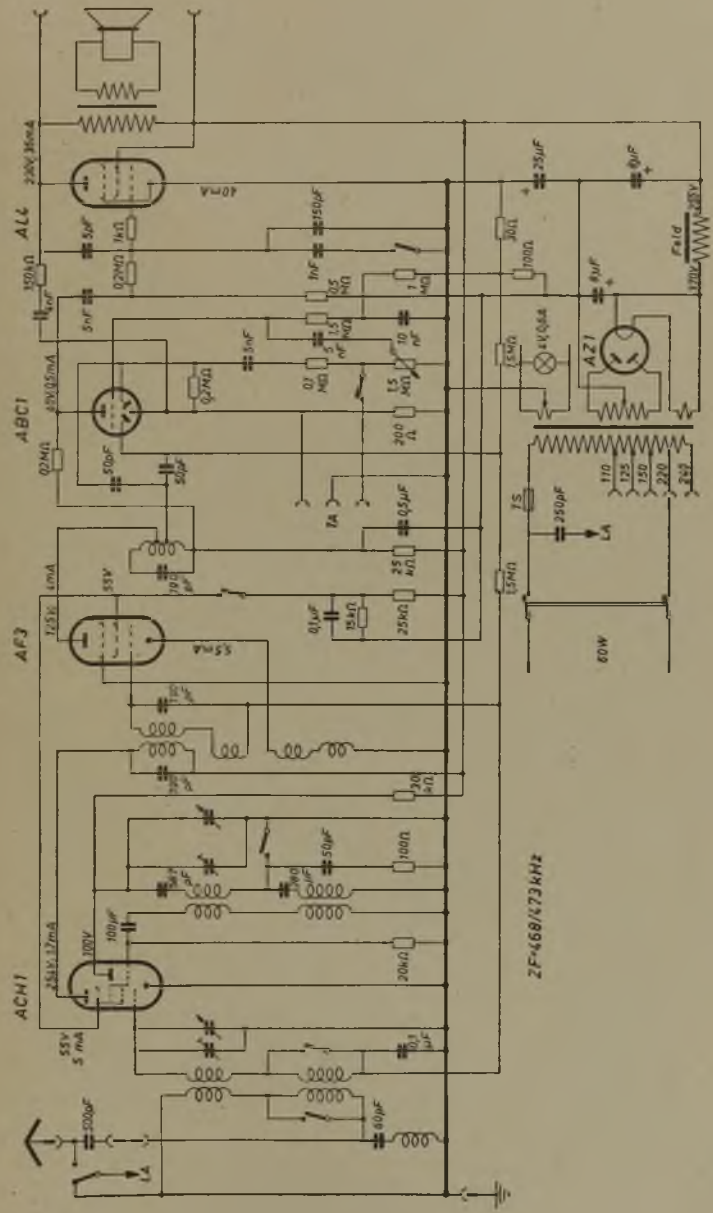

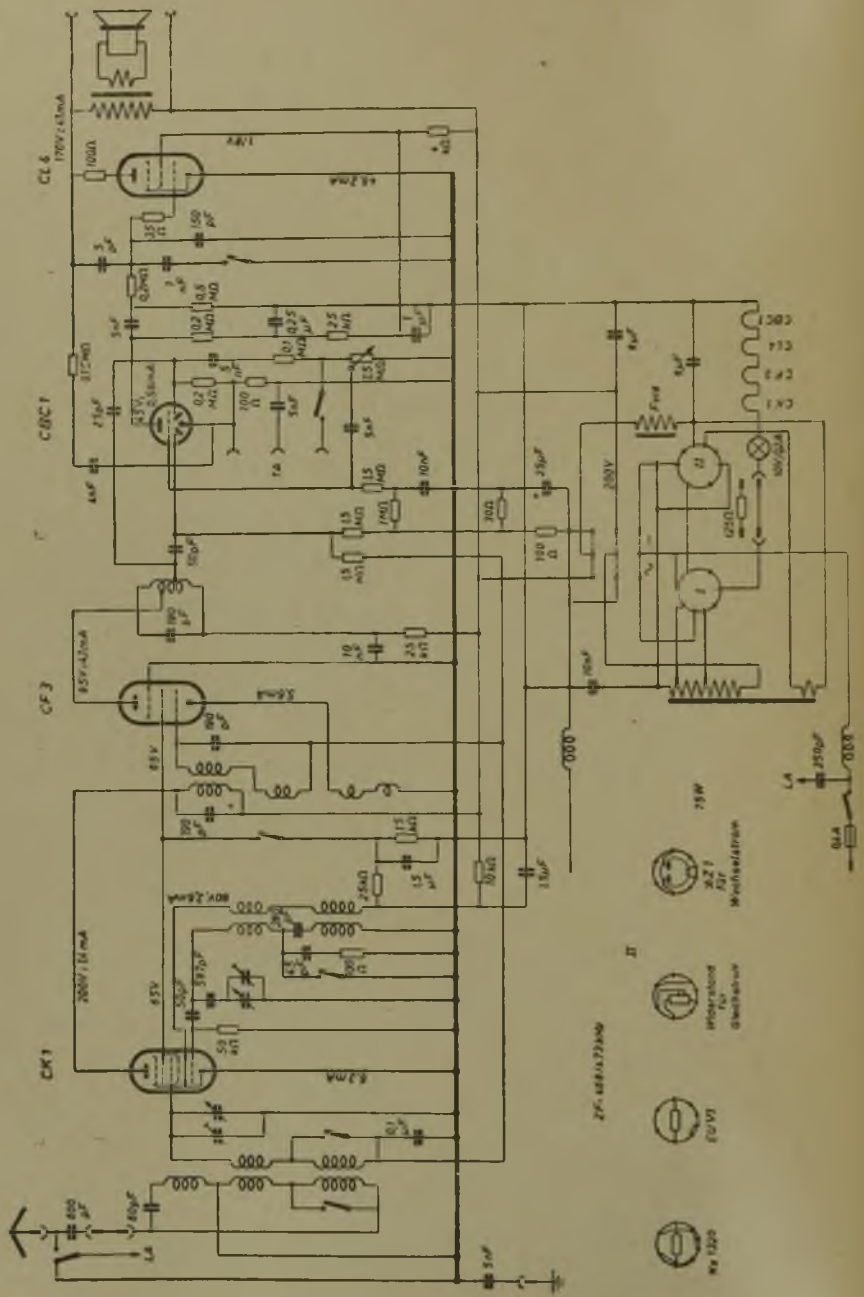

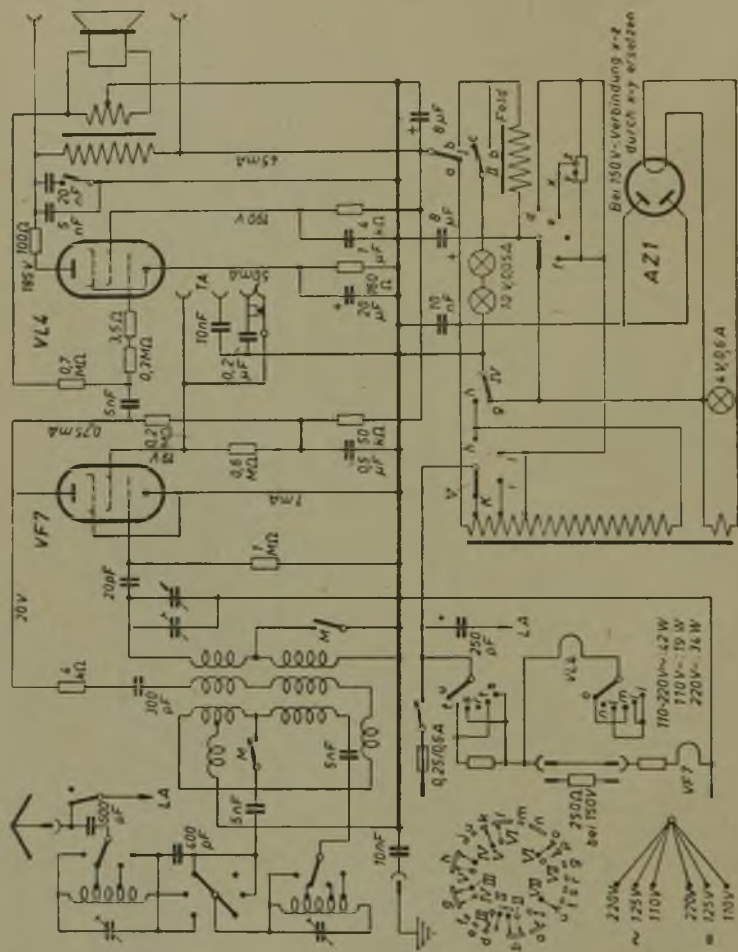

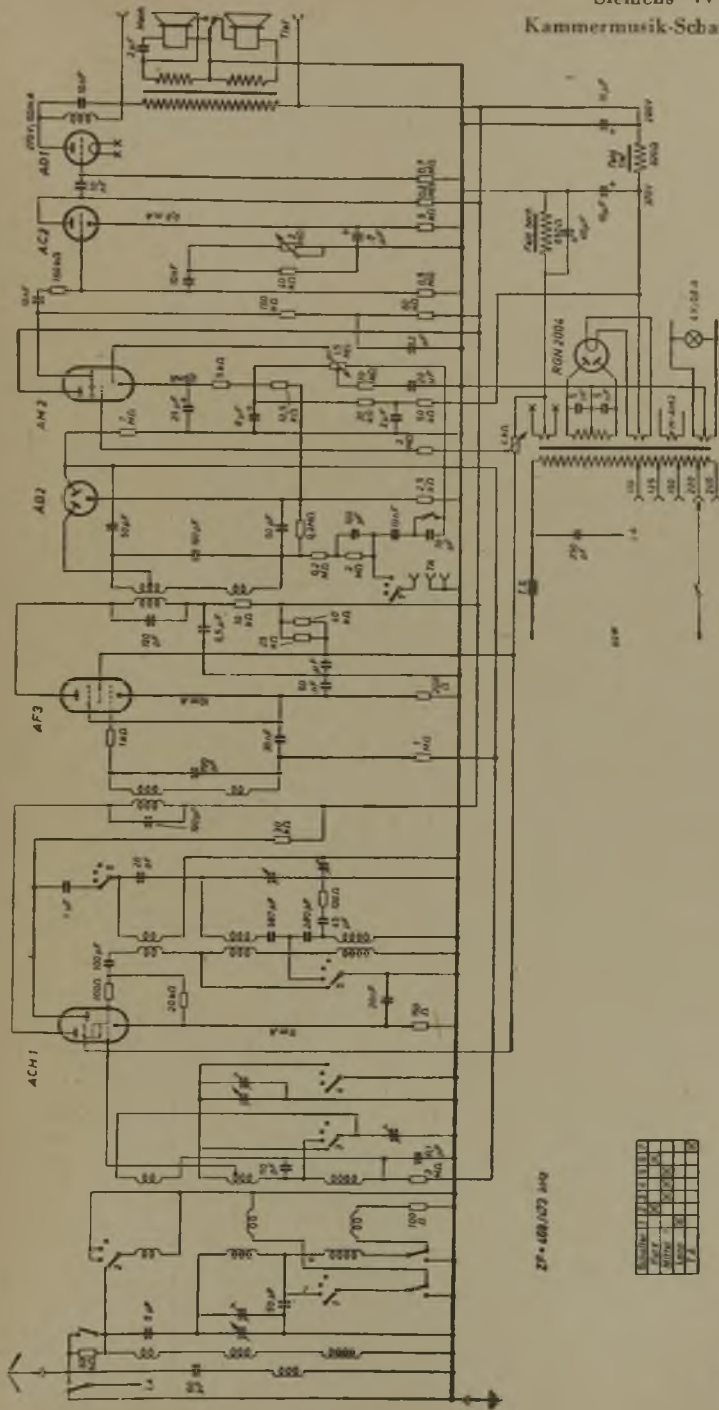

ZF-408/07 440

1	2	3	4	5	6	7	8	9	10
11	12	13	14	15	16	17	18	19	20
21	22	23	24	25	26	27	28	29	30
31	32	33	34	35	36	37	38	39	40

Siemens 75 W Standard

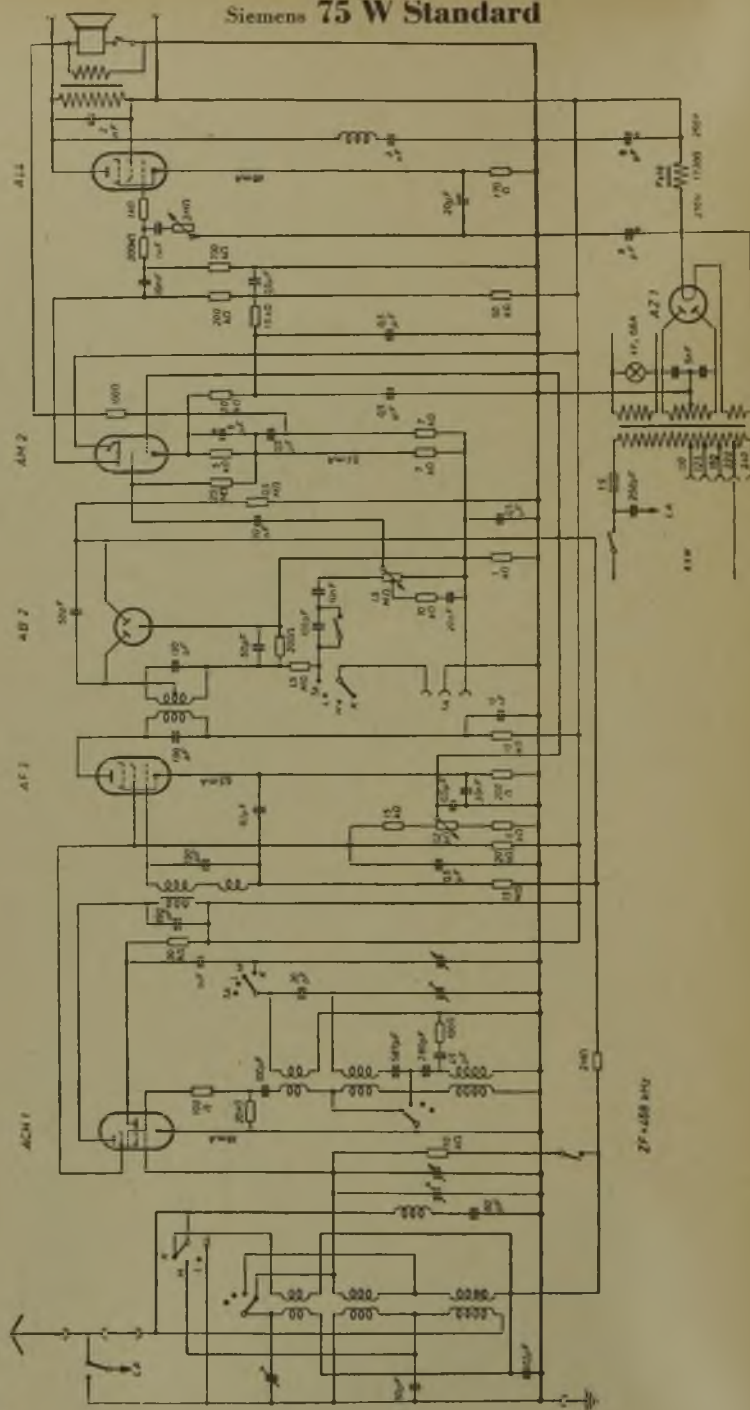

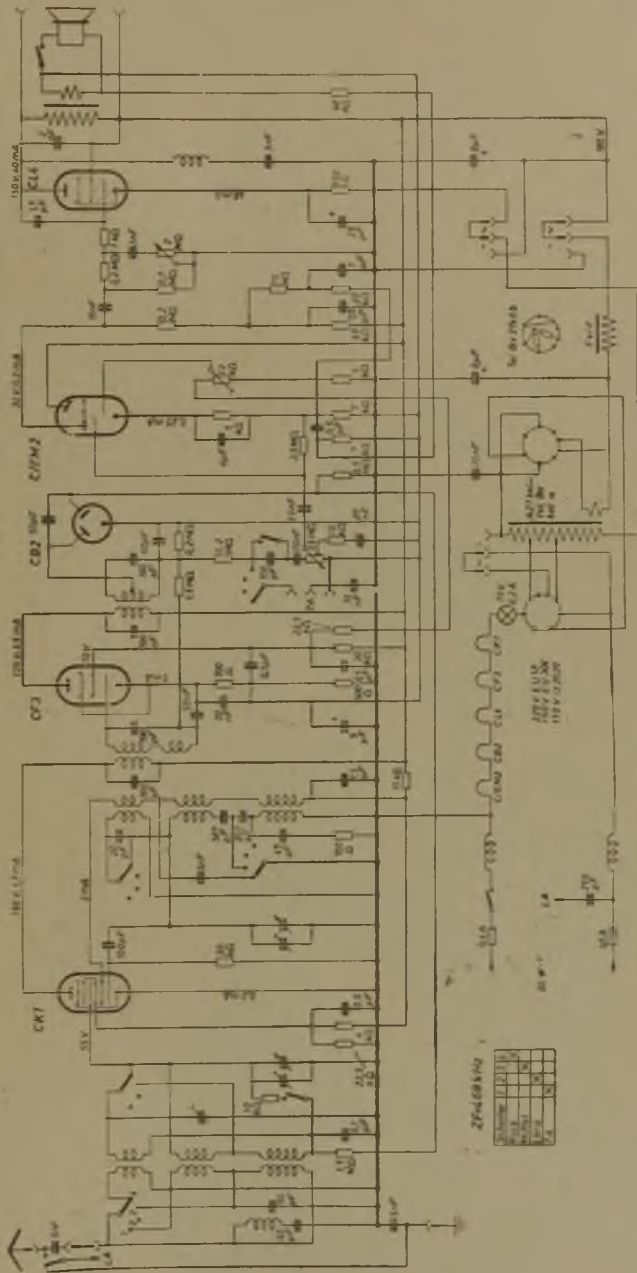

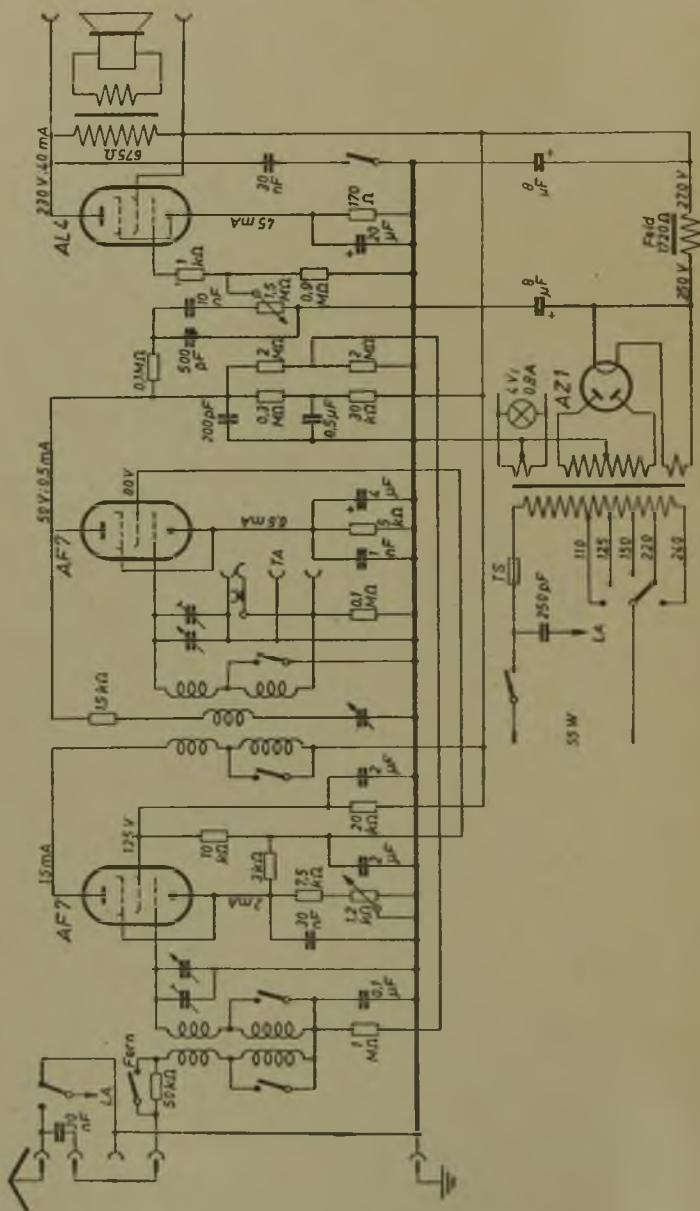

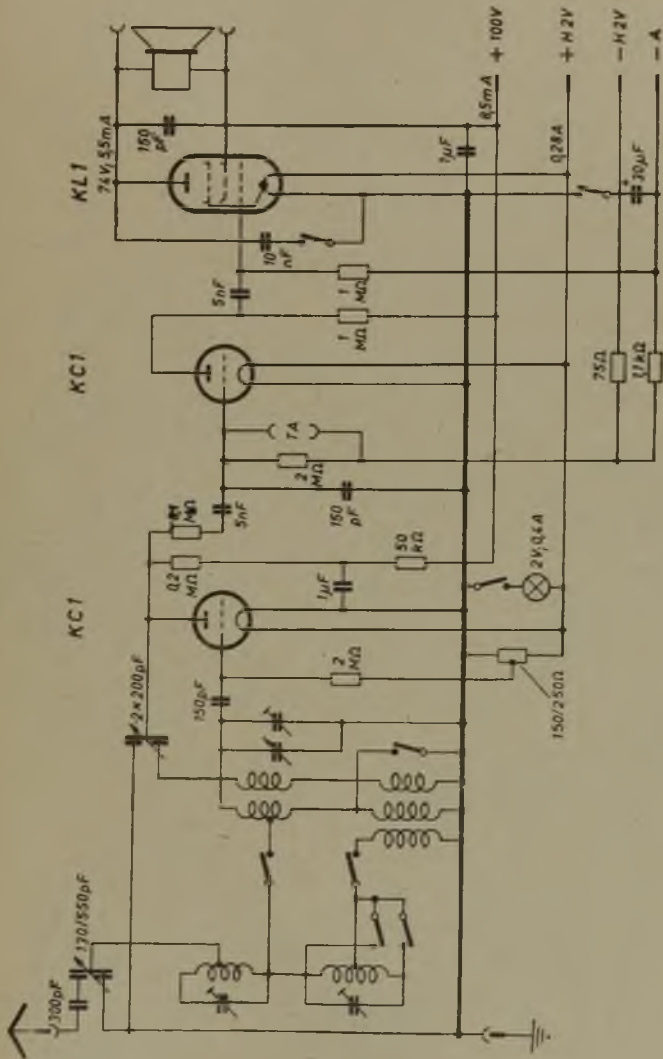

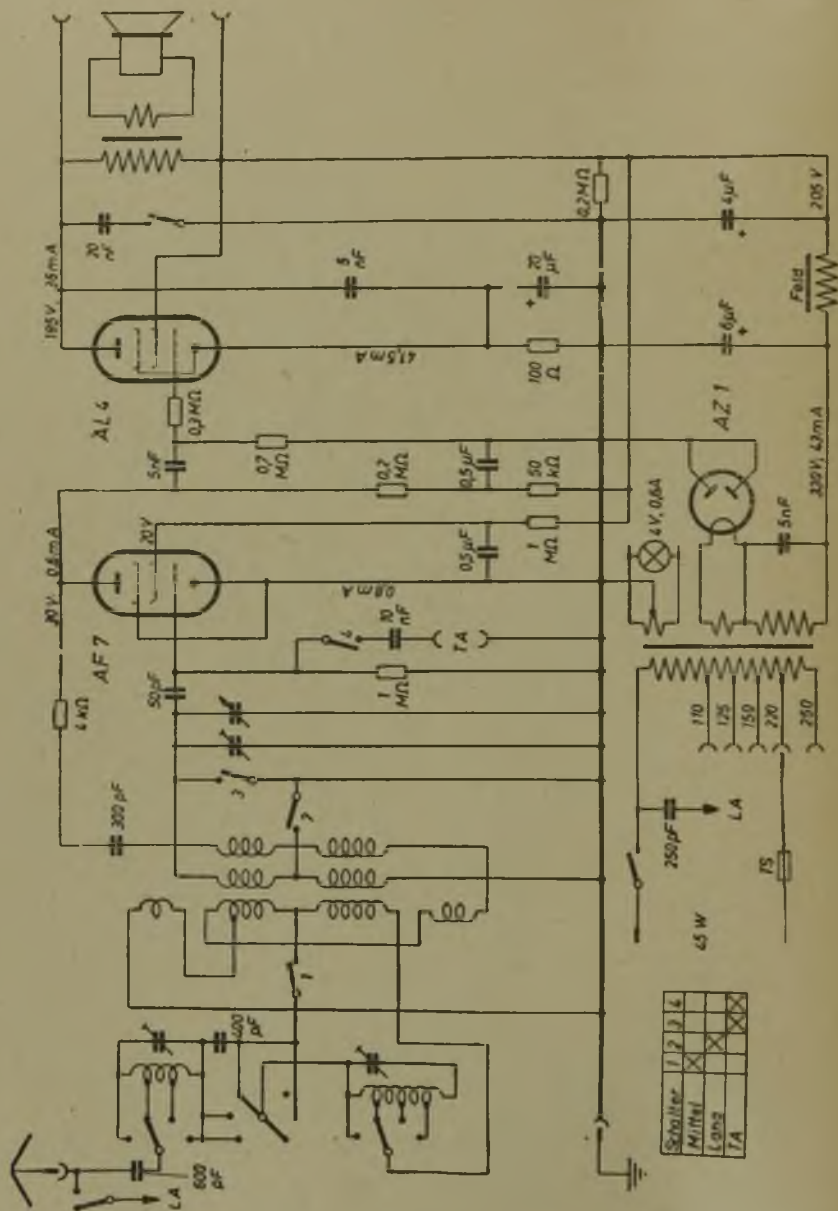

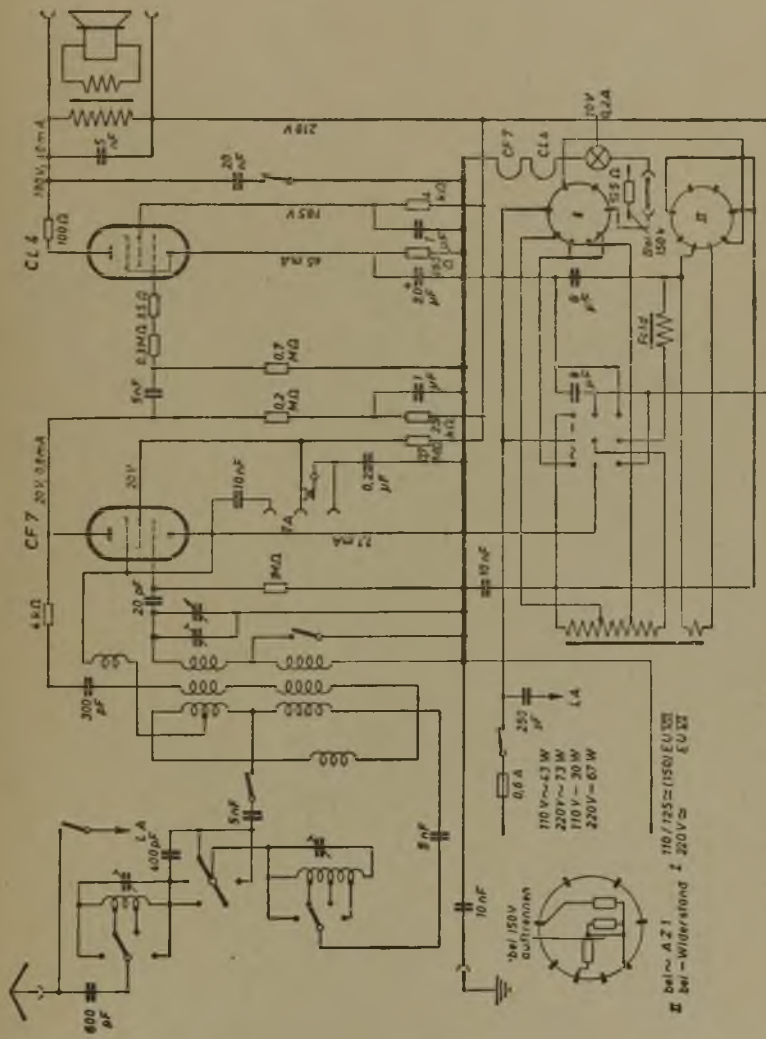

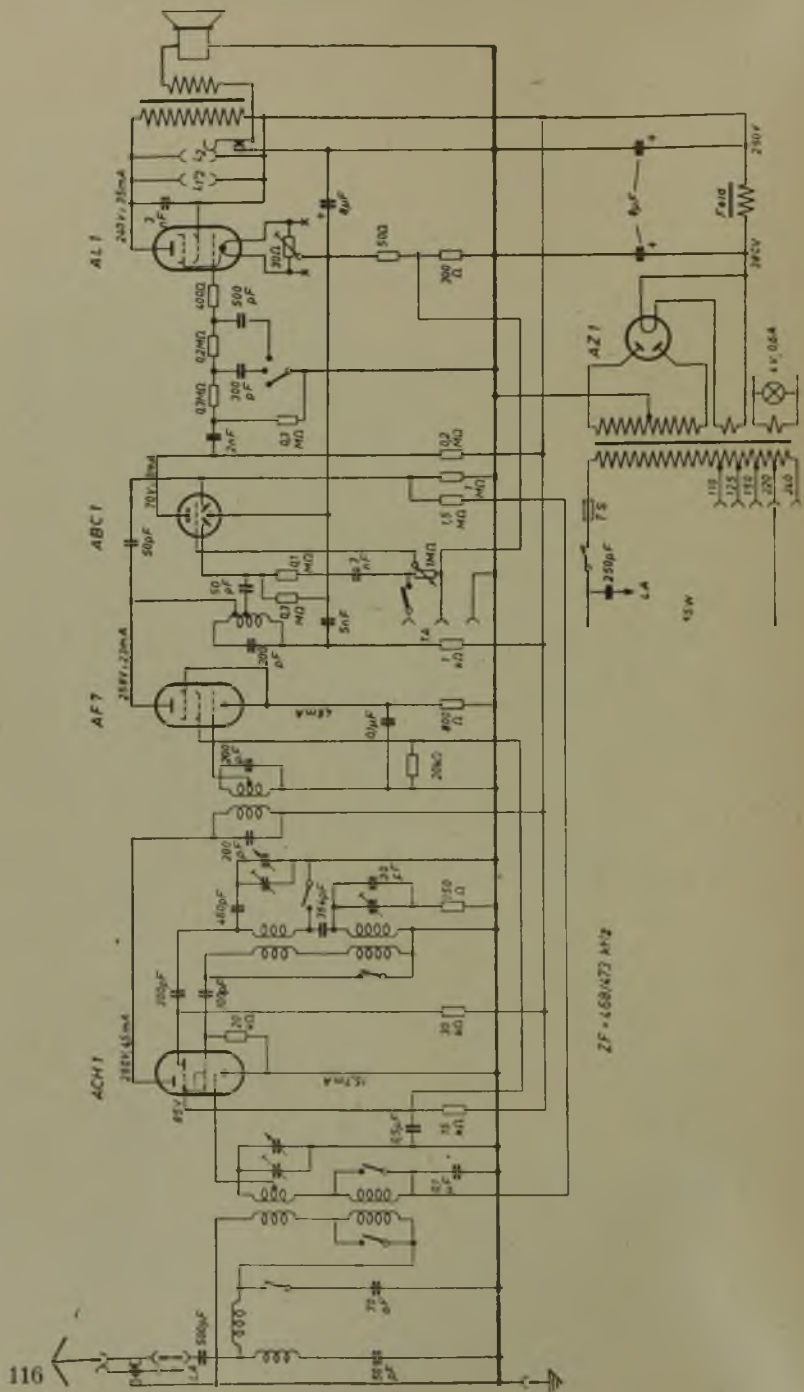

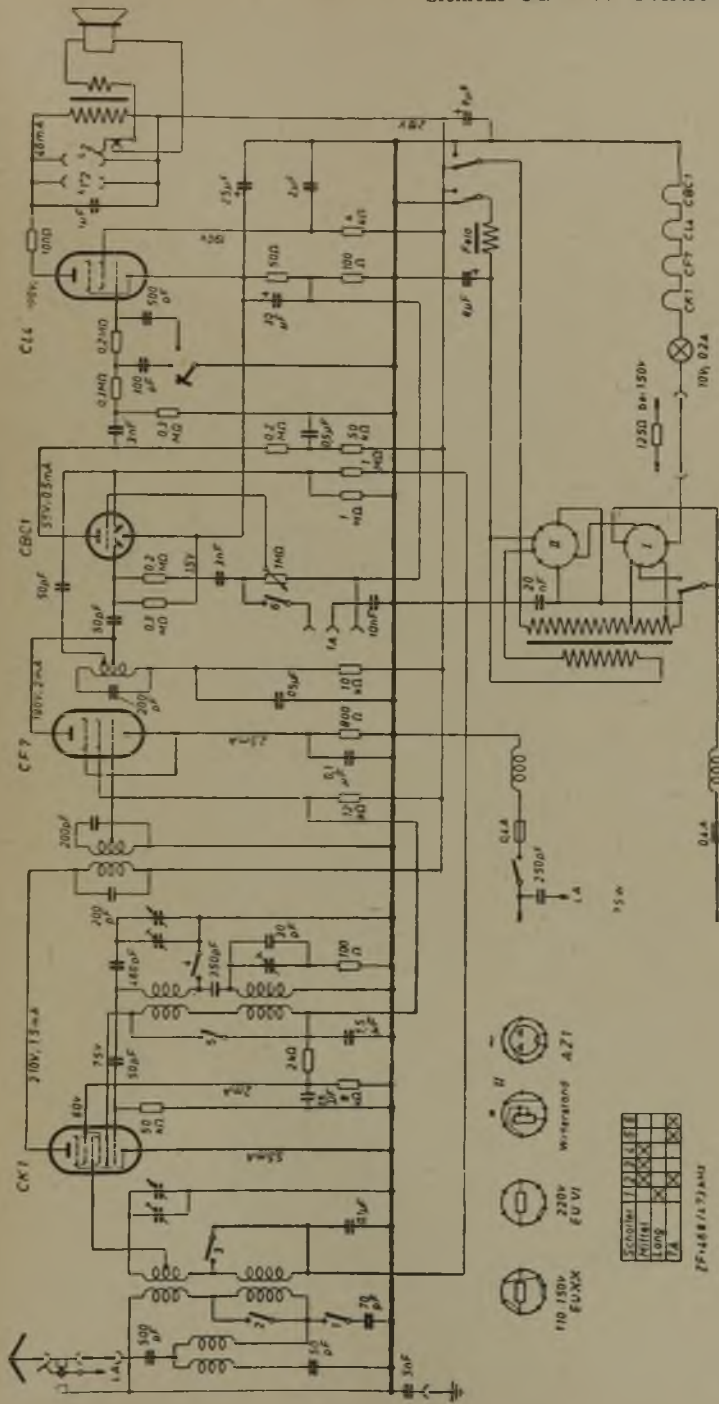

- 110/130V EUXX
- 220V Wierkring 4Z1
- 75W
- 1.4
- 250pF
- 0.4A

Schaltplan	1	2	3	4	5
Platt	1	2	3	4	5
Long	1	2	3	4	5
LA	1	2	3	4	5

ZF-488/173/21

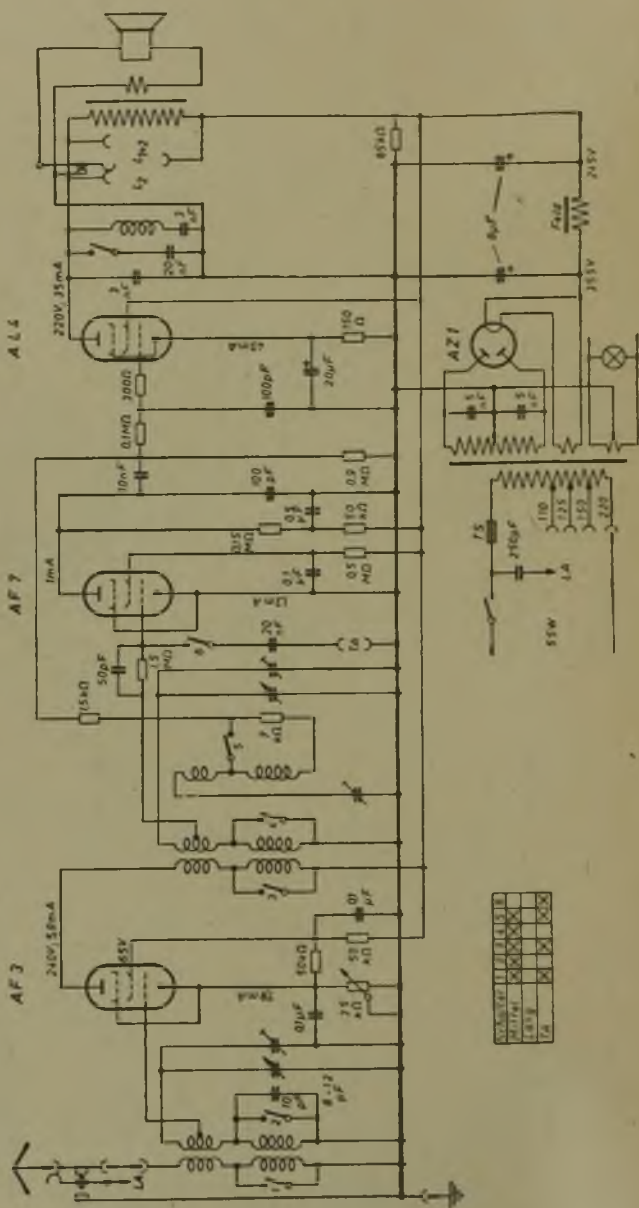

250V	210V	110V	225V	150V	225V
55W	250V	10000μF	1000μF	500μF	200μF
10000μF	1000μF	500μF	200μF	100μF	50μF
20μF	10μF	5μF	2μF	1μF	0.5μF
0.2μF	0.1μF	0.05μF	0.01μF	0.001μF	

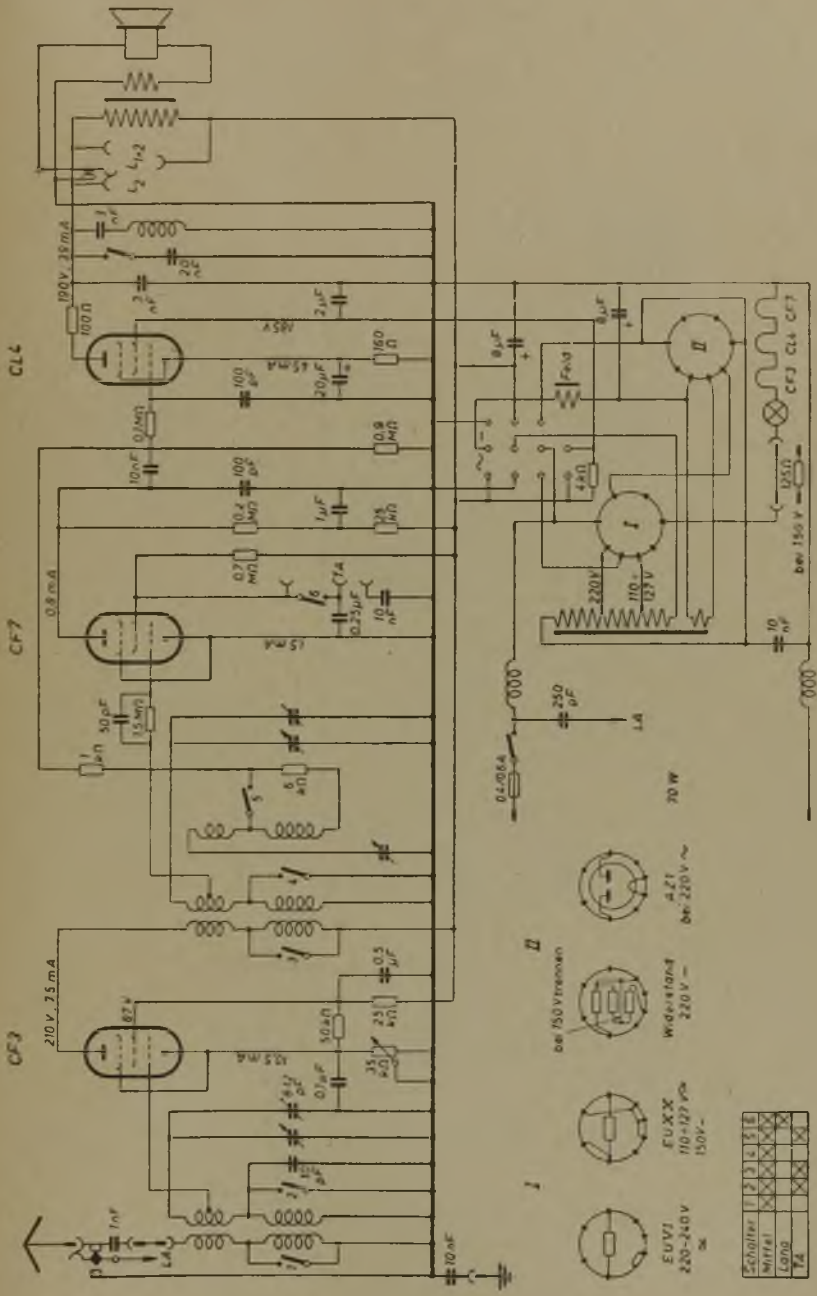

Schalter	1	2	3	4	5
Mittel	X	X	X	X	X
Licht	X	X	X	X	X
LA	X	X	X	X	X

- I
- II
- III
- de 150 Voltoren
- EUVI 230-240V
- EUVX 110-127V
- de 220V ~
- 4-Z
- de 220V ~
- Widerstand 220V ~
- 30 W
- LA

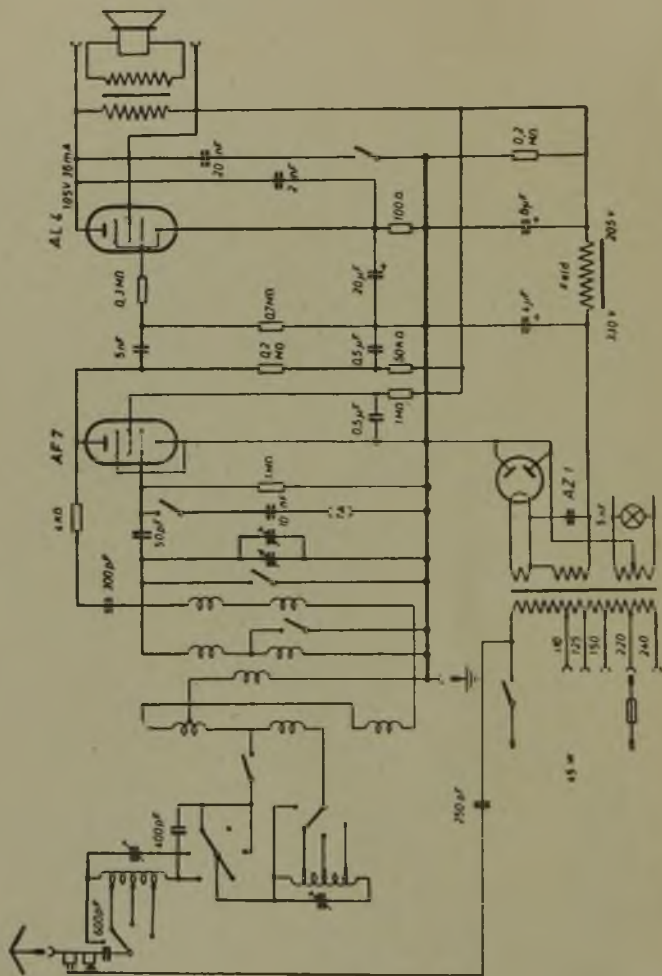

Siemens 57 WLK

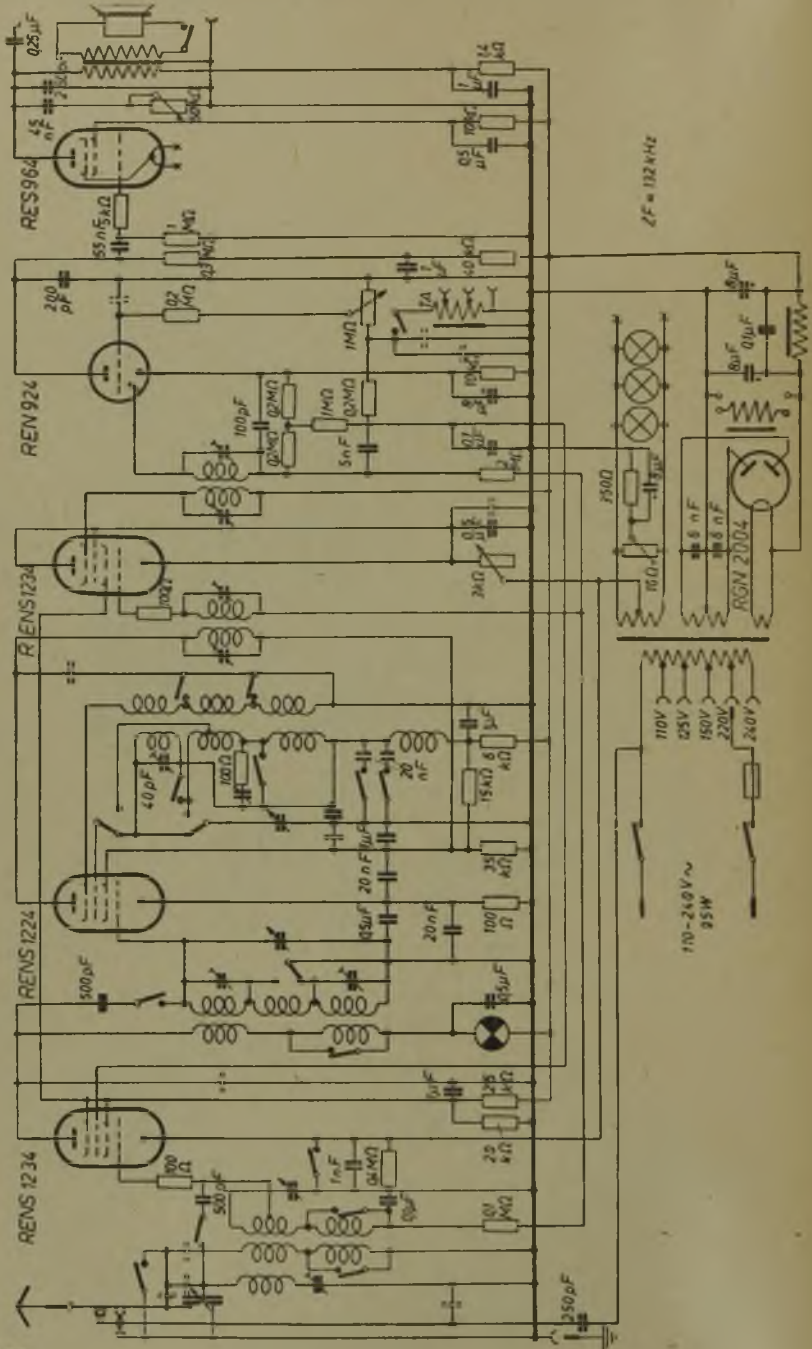

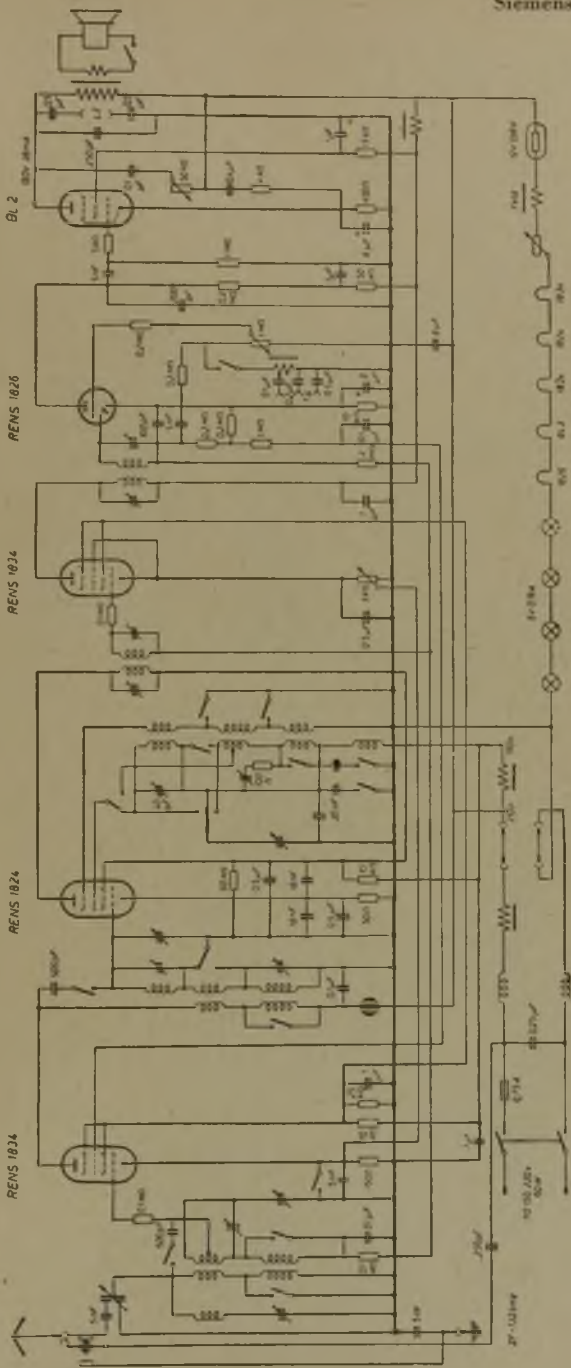

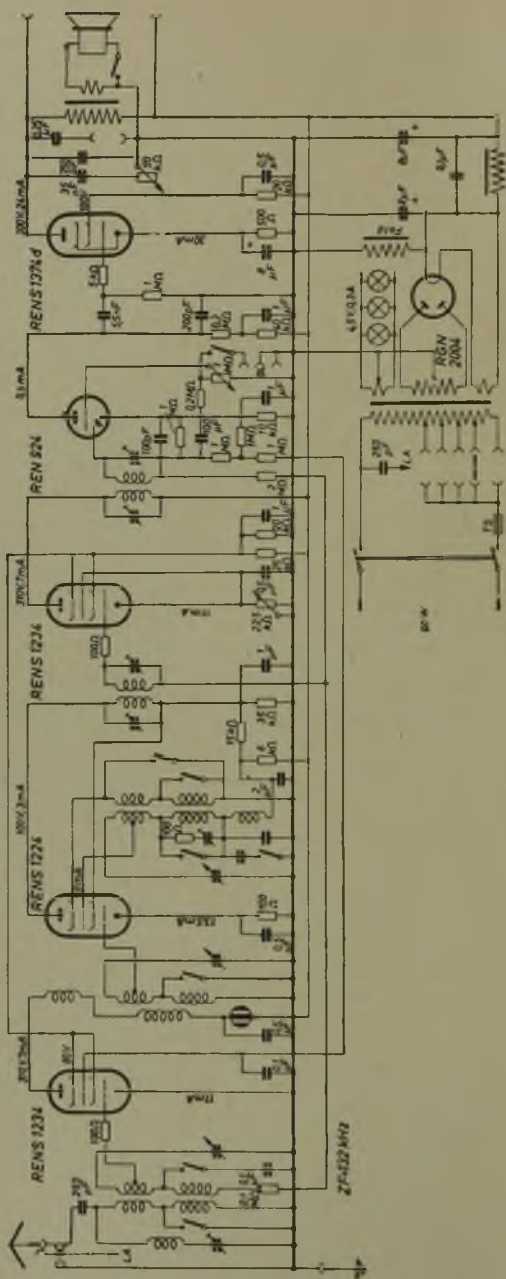

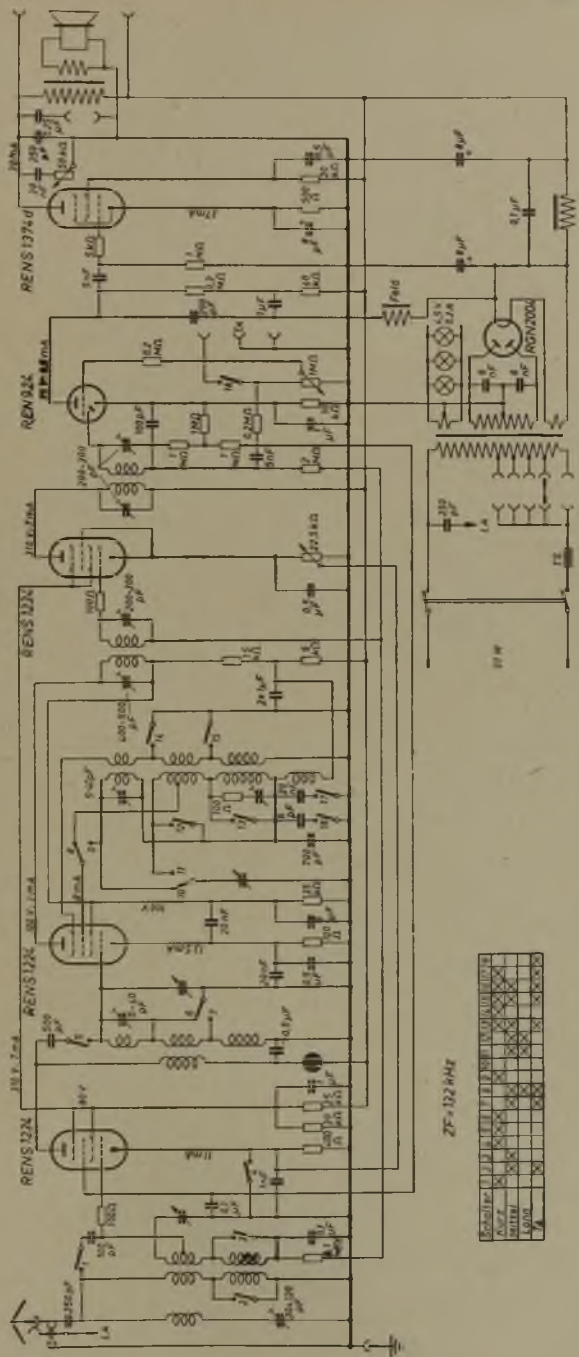

2F=122 kHz

RESONANZ	1	2	3	4	5	6	7	8	9	10	11	12	13	14	15	16	17	18	19	20
WERT	10	20	30	40	50	60	70	80	90	100	150	200	300	400	500	600	700	800	900	1000
LAUF	X	X	X	X	X	X	X	X	X	X	X	X	X	X	X	X	X	X	X	X
LAUF	X	X	X	X	X	X	X	X	X	X	X	X	X	X	X	X	X	X	X	X

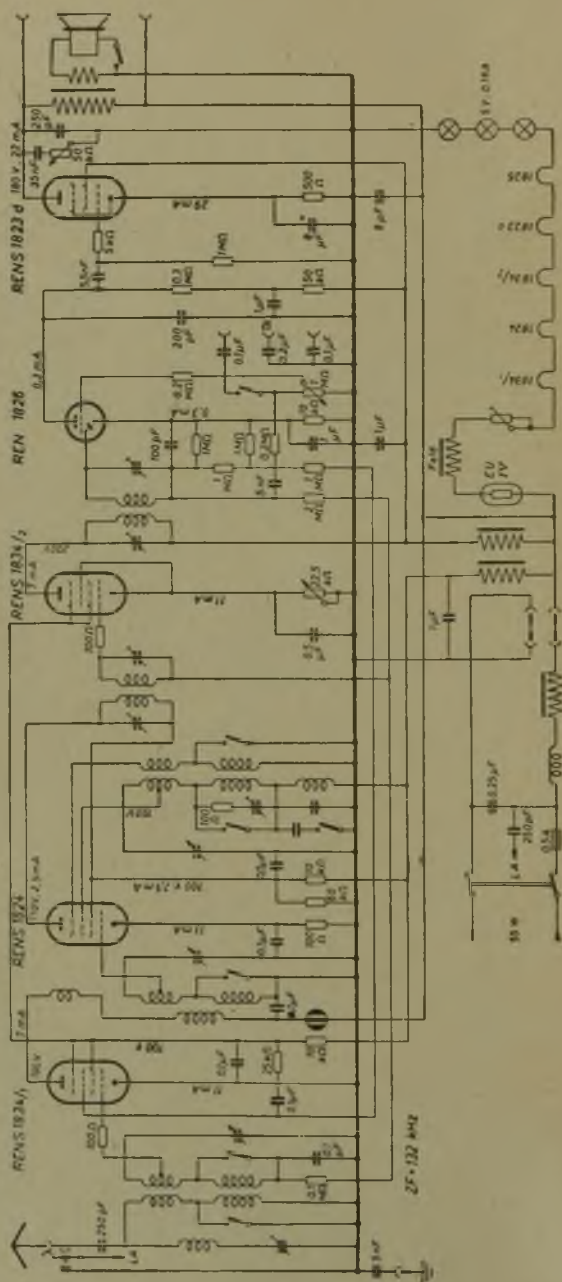

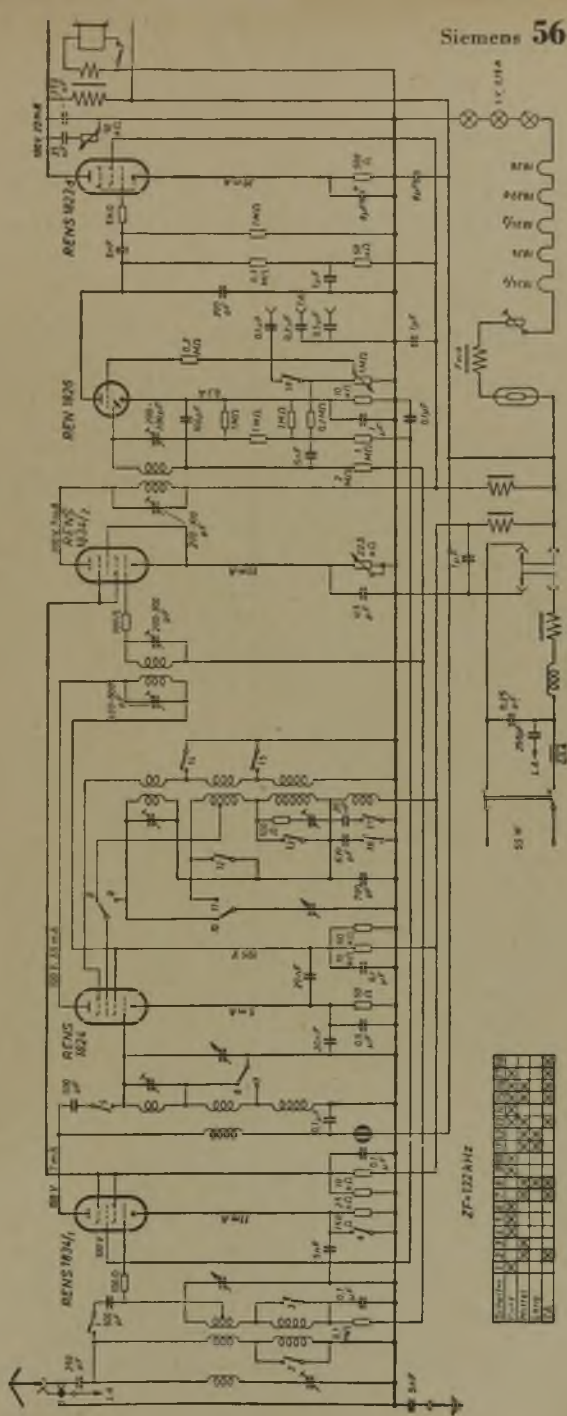

Pos.	1	2	3	4	5	6	7	8	9	10	11	12	13	14	15	16	17	18	19	20
1																				
2																				
3																				
4																				
5																				
6																				
7																				
8																				
9																				
10																				
11																				
12																				
13																				
14																				
15																				
16																				
17																				
18																				
19																				
20																				

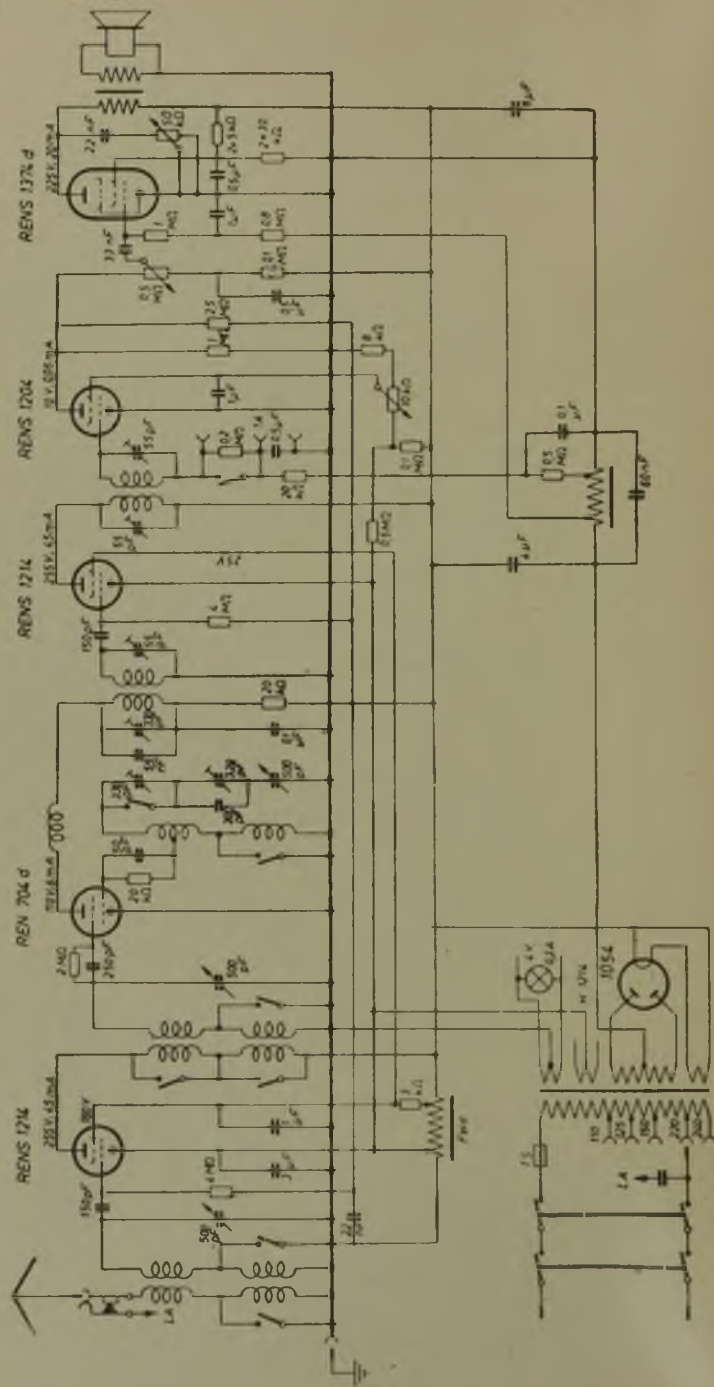

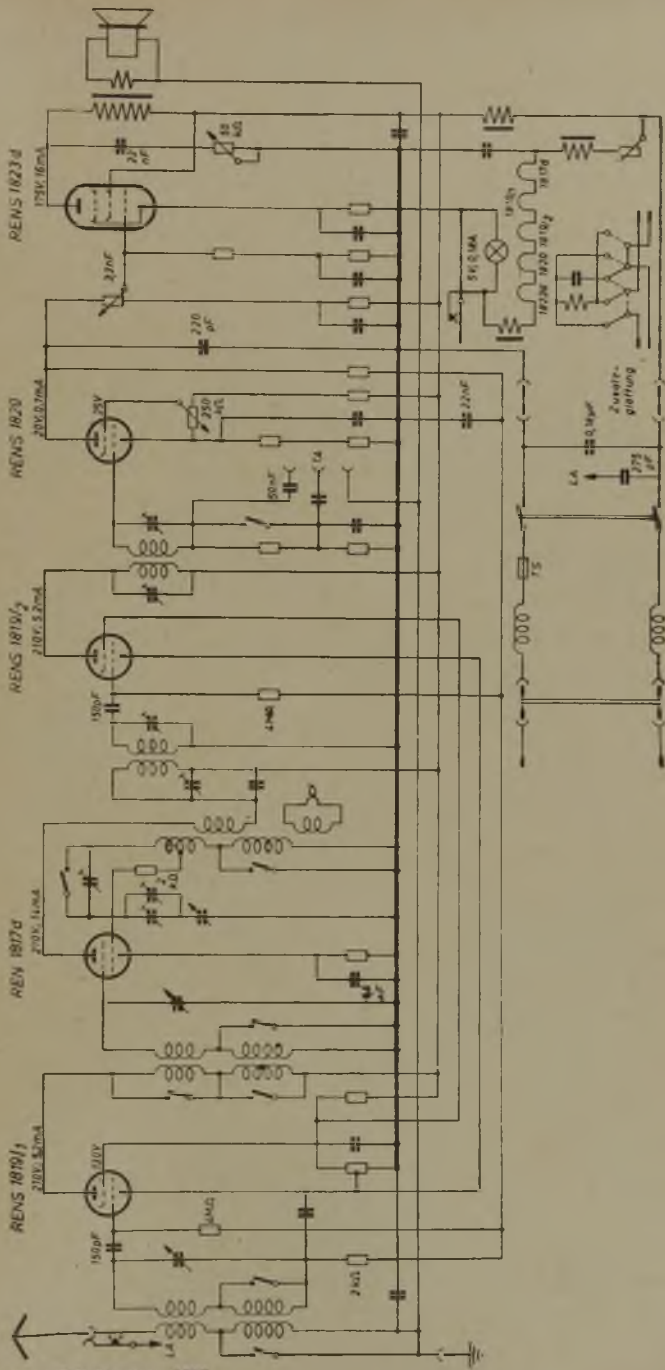

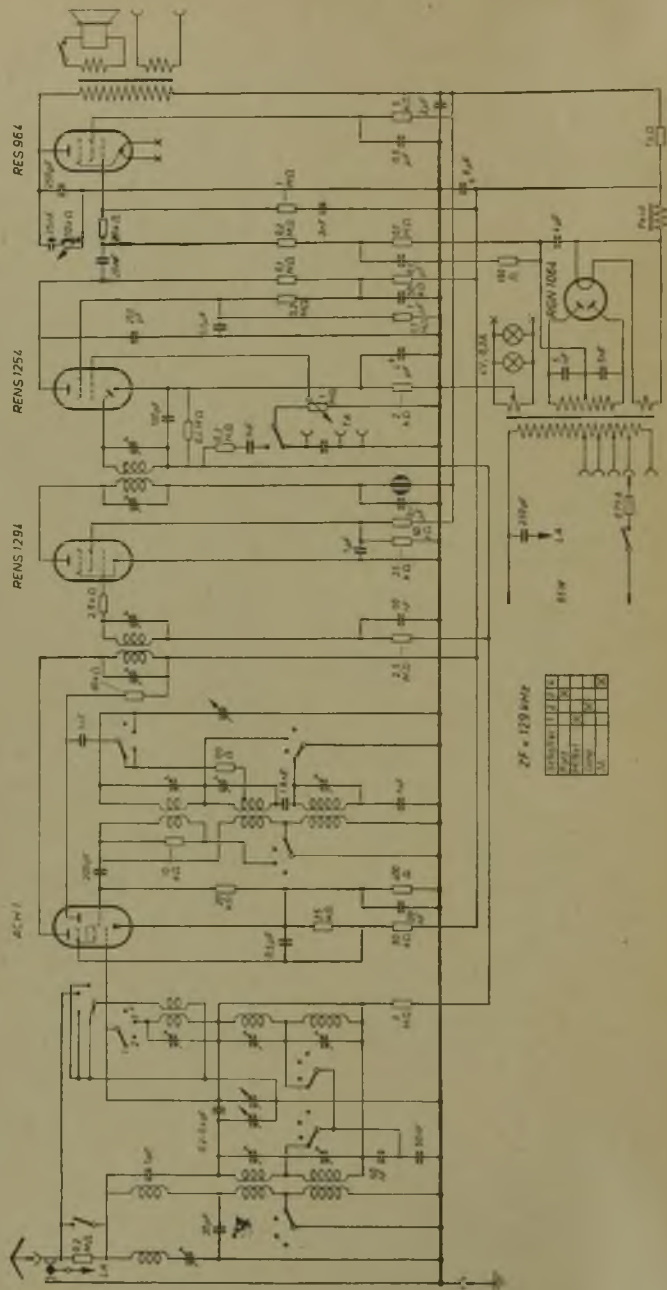

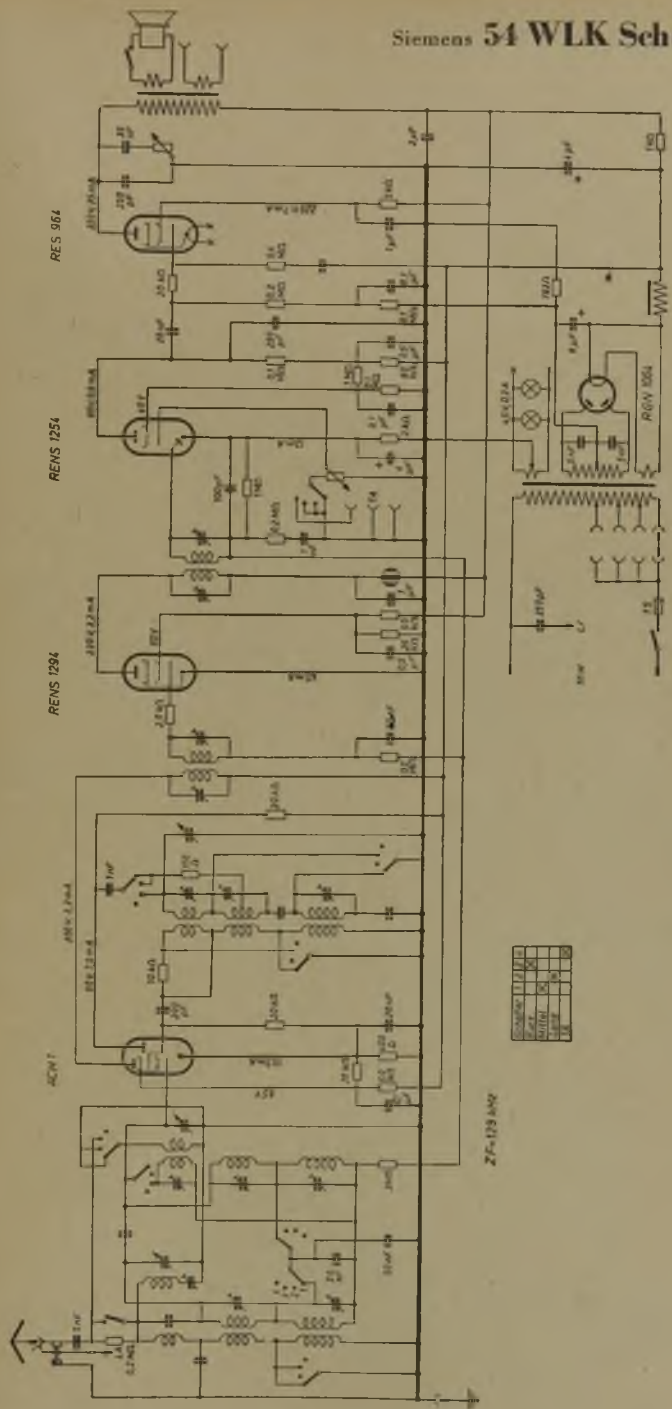

1	2	3	4	5	6
7	8	9	10	11	12
13	14	15	16	17	18
19	20	21	22	23	24

Siemens 54 GLK Schatulle

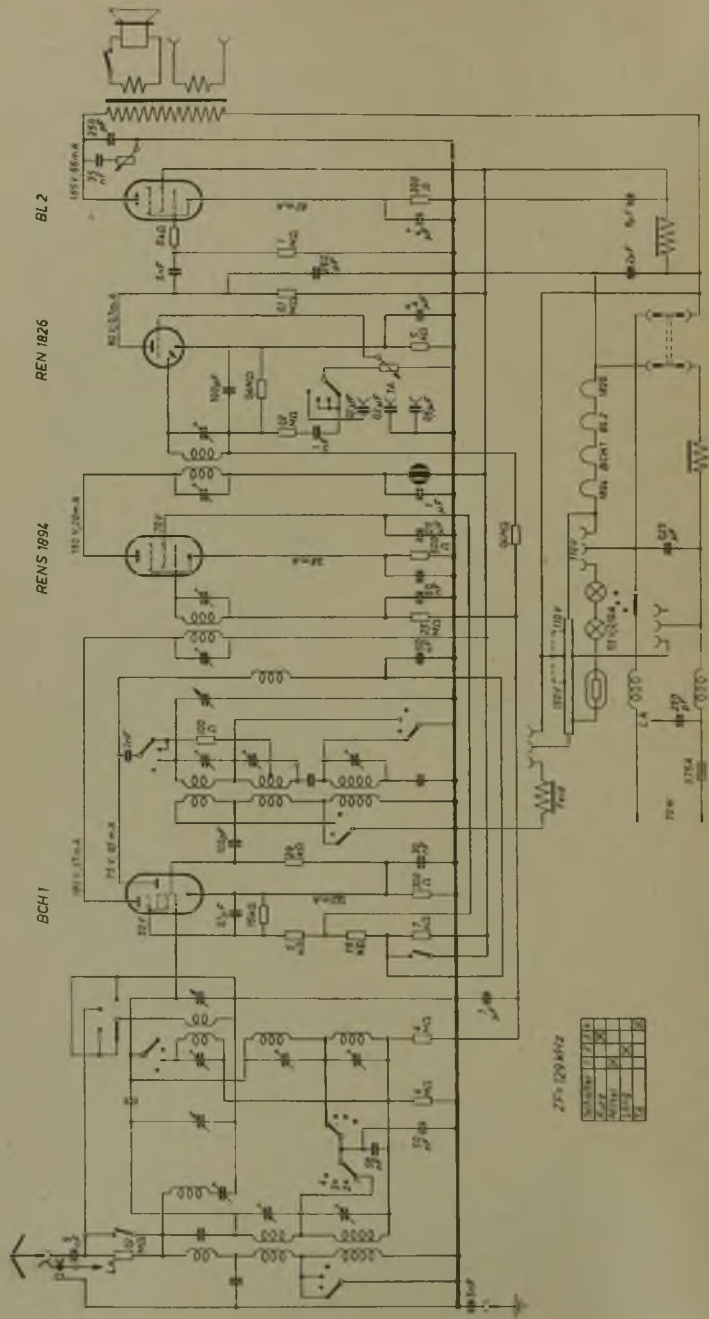

275 129 6172

1	2	3	4	5	6	7	8	9	10	11	12	13	14	15	16	17	18	19	20	21	22	23	24	25	26	27	28	29	30	31	32	33	34	35	36	37	38	39	40	41	42	43	44	45	46	47	48	49	50	51	52	53	54	55	56	57	58	59	60	61	62	63	64	65	66	67	68	69	70	71	72	73	74	75	76	77	78	79	80	81	82	83	84	85	86	87	88	89	90	91	92	93	94	95	96	97	98	99	100
---	---	---	---	---	---	---	---	---	----	----	----	----	----	----	----	----	----	----	----	----	----	----	----	----	----	----	----	----	----	----	----	----	----	----	----	----	----	----	----	----	----	----	----	----	----	----	----	----	----	----	----	----	----	----	----	----	----	----	----	----	----	----	----	----	----	----	----	----	----	----	----	----	----	----	----	----	----	----	----	----	----	----	----	----	----	----	----	----	----	----	----	----	----	----	----	----	----	----	-----

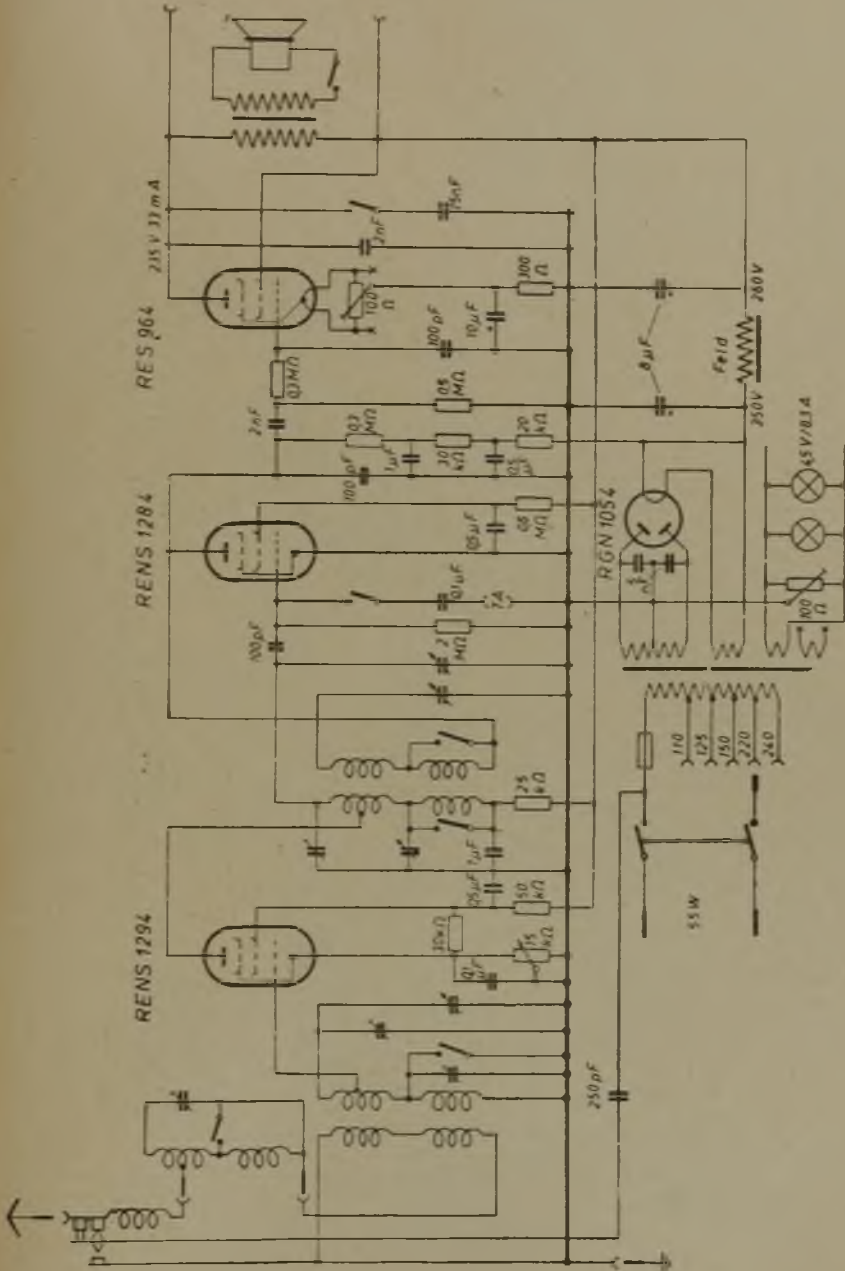

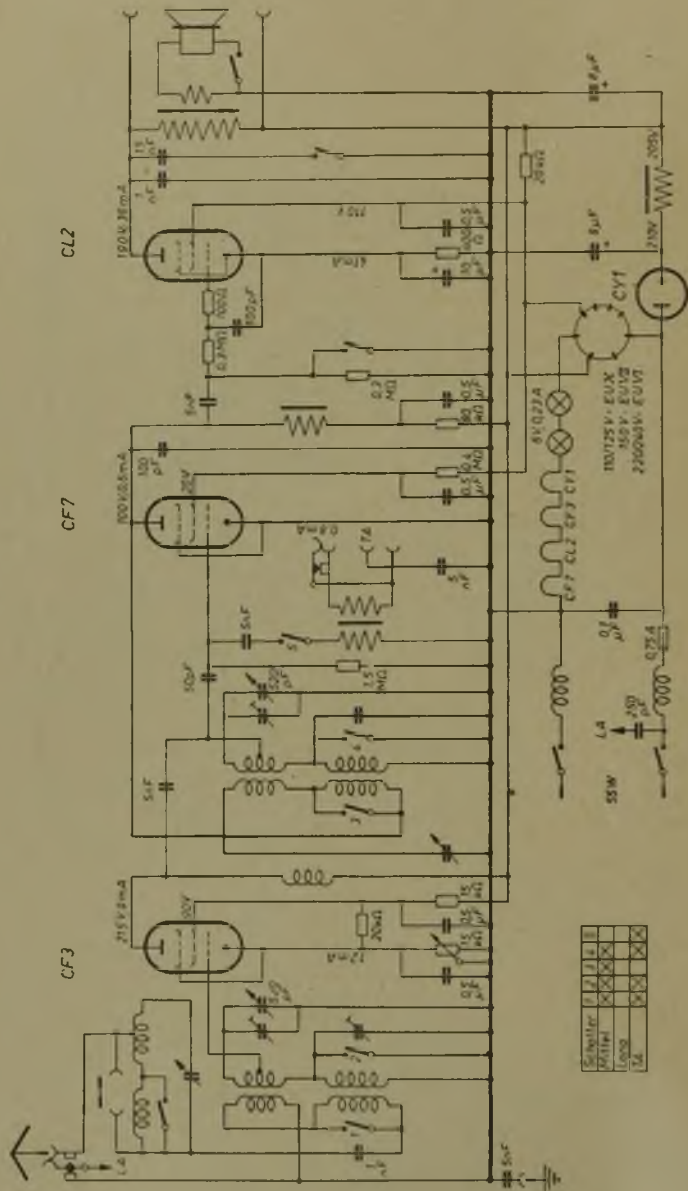

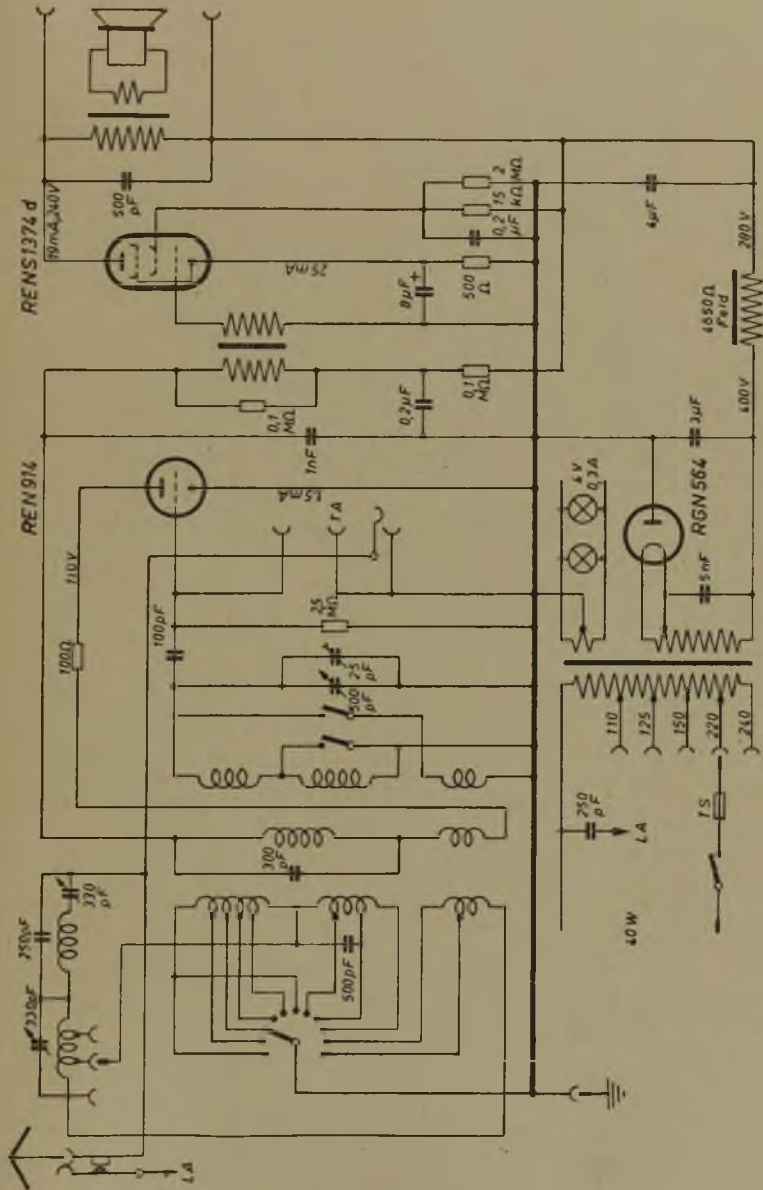

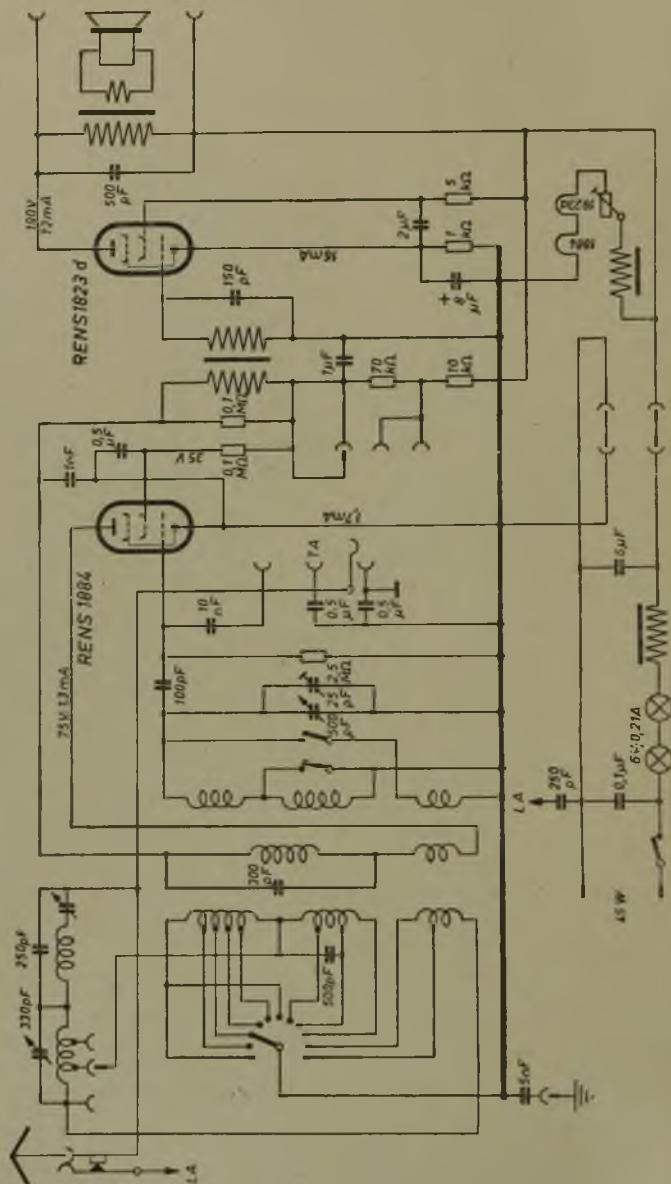

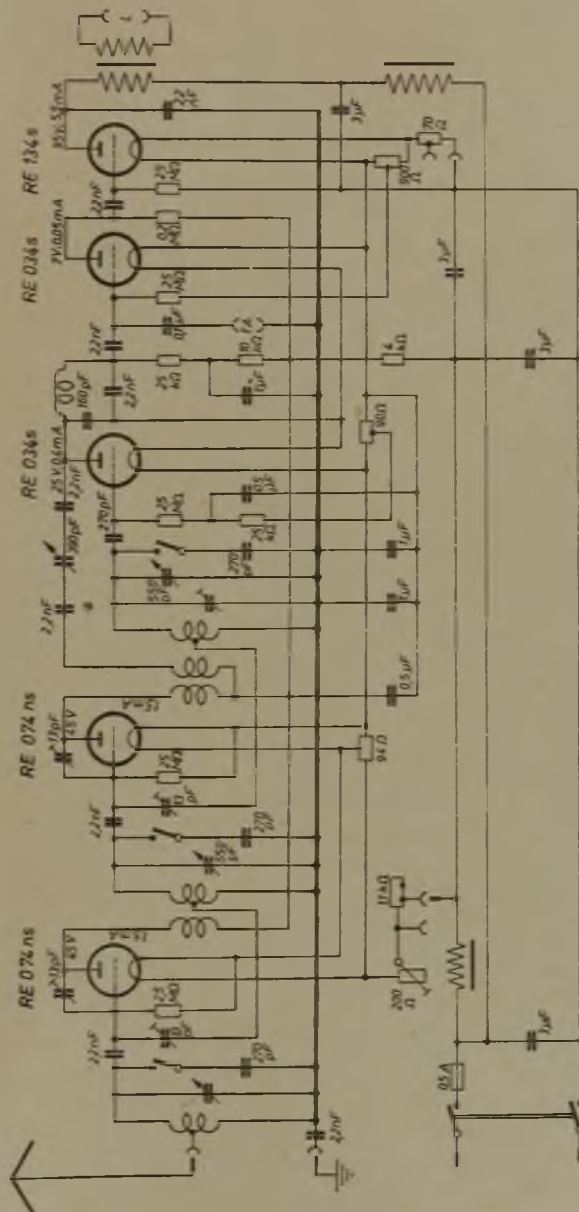

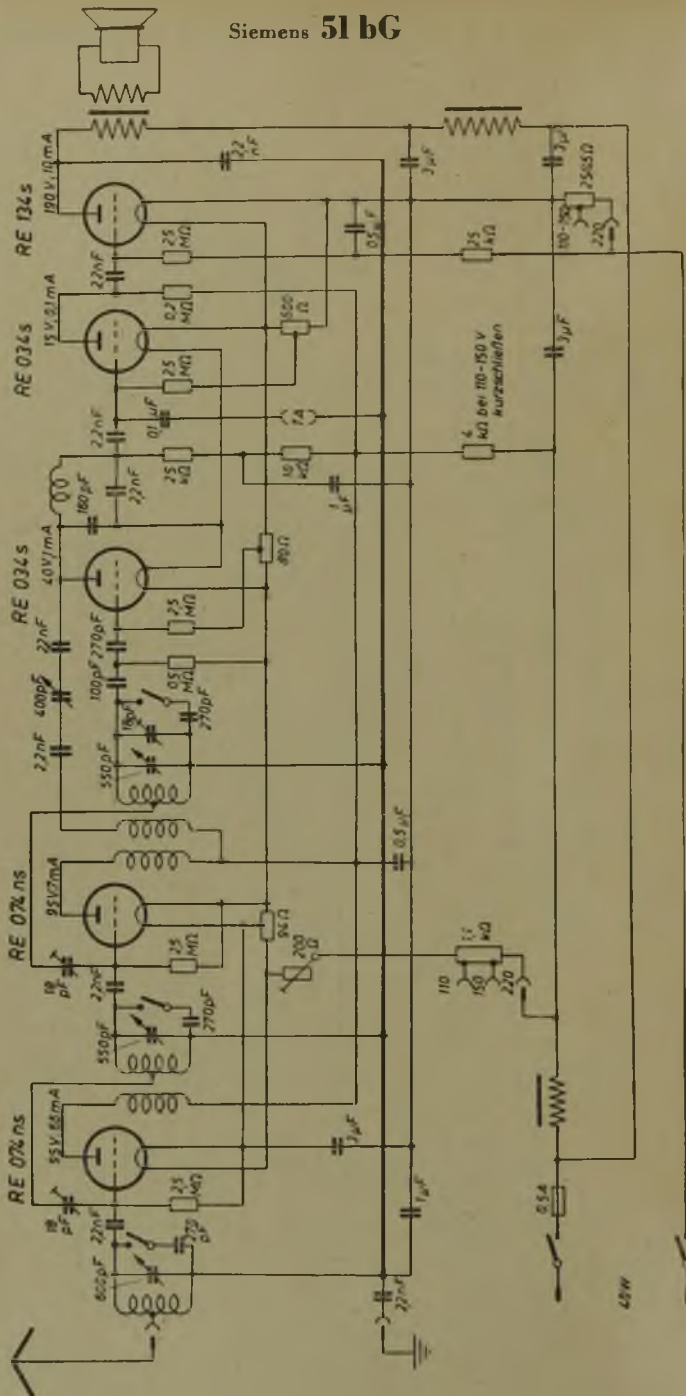

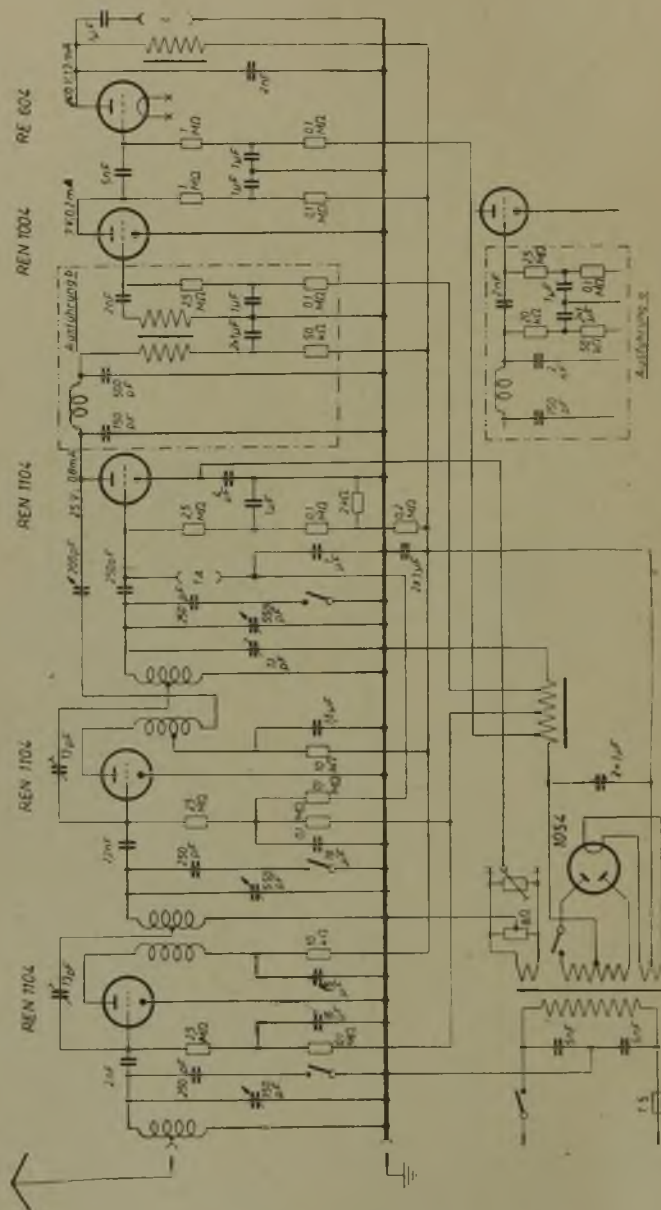

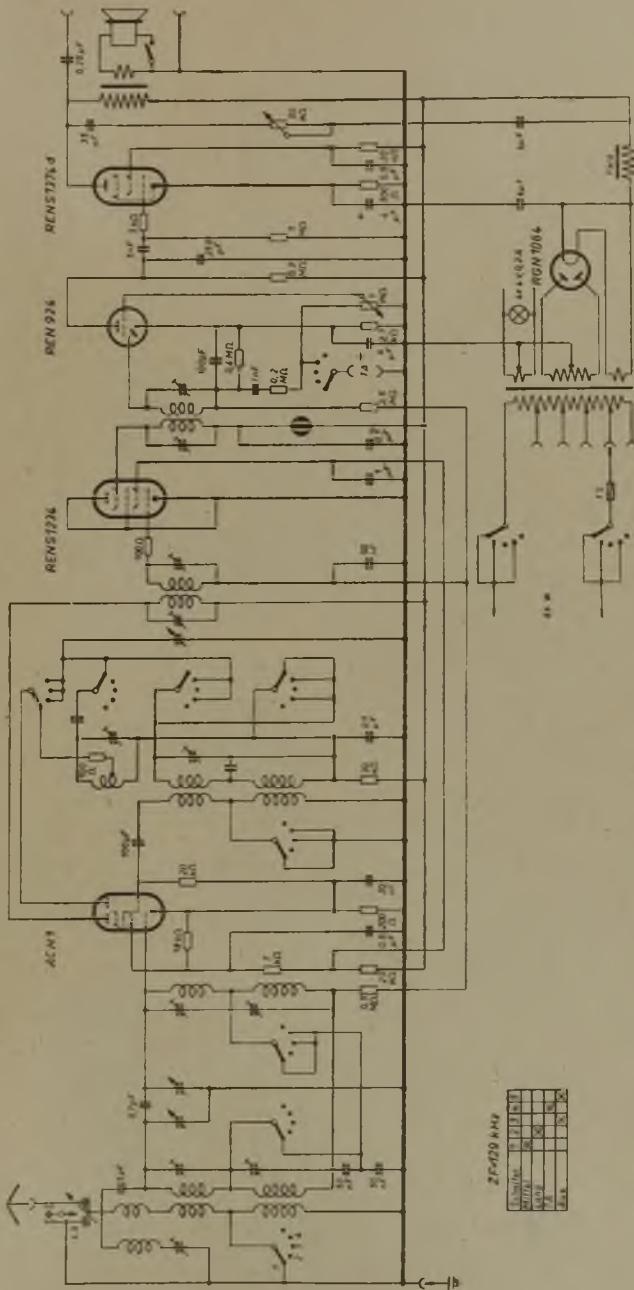

2F=120 kHz

1	2	3	4	5	6	7	8	9	10
1	2	3	4	5	6	7	8	9	10
1	2	3	4	5	6	7	8	9	10
1	2	3	4	5	6	7	8	9	10
1	2	3	4	5	6	7	8	9	10

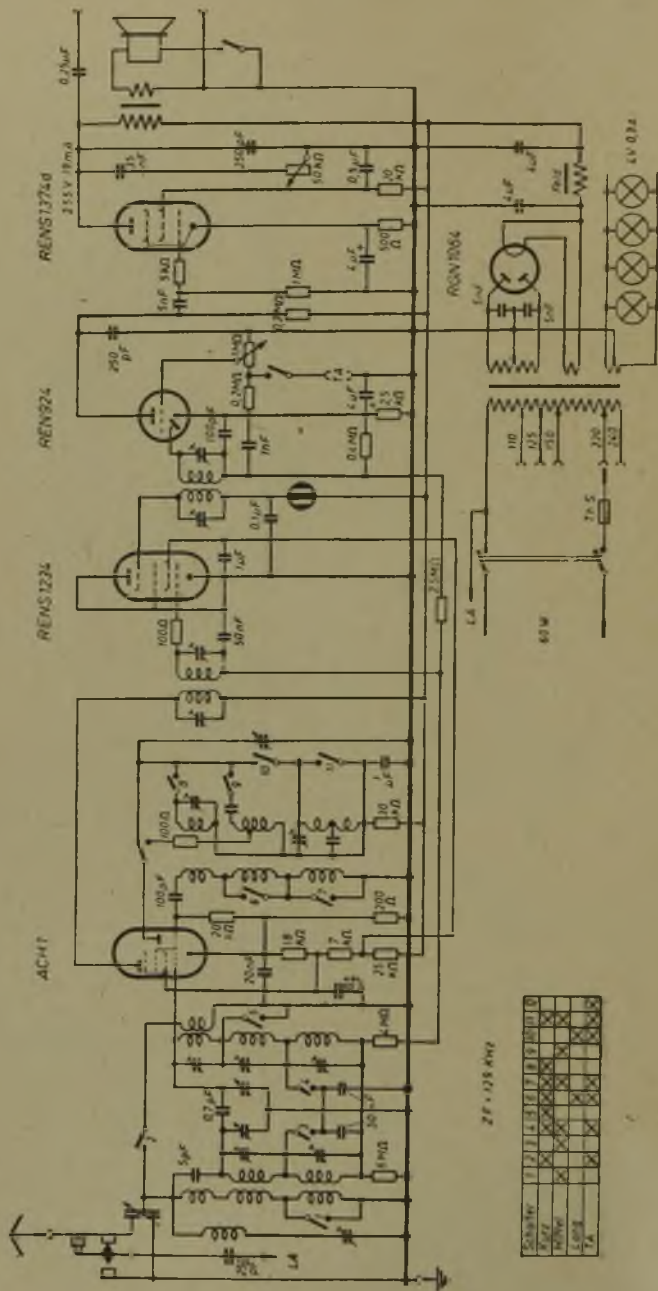

ZF = 128 kHz

Symbol	1	2	3	4	5	6	7	8	9	10	11	12
Schalt	X	X	X	X	X	X	X	X	X	X	X	X
WZ	X	X	X	X	X	X	X	X	X	X	X	X
WZ	X	X	X	X	X	X	X	X	X	X	X	X
Log	X	X	X	X	X	X	X	X	X	X	X	X
TA	X	X	X	X	X	X	X	X	X	X	X	X

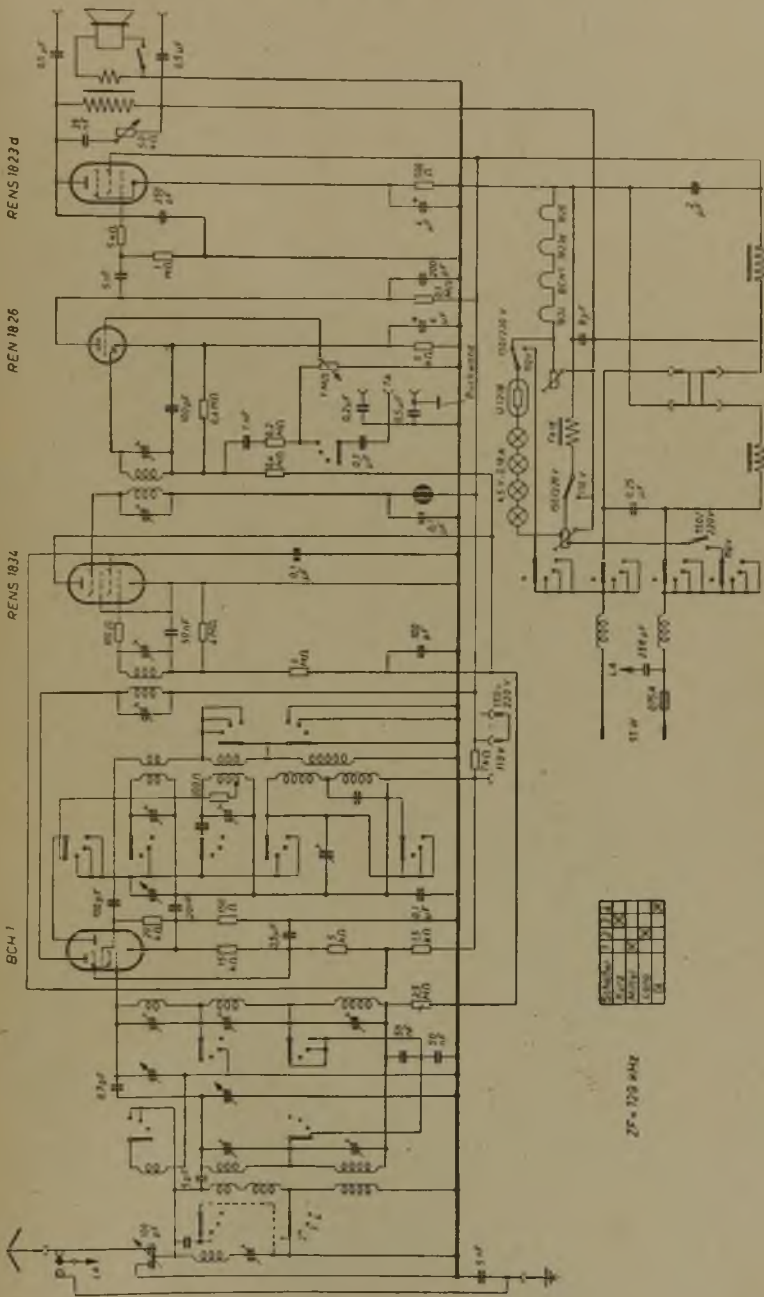

TYPE	VALUE	UNIT
RESISTANCE	10	Ω
RESISTANCE	100	Ω
RESISTANCE	1000	Ω
RESISTANCE	10000	Ω
RESISTANCE	100000	Ω
RESISTANCE	1000000	Ω

ZF = 120 kHz

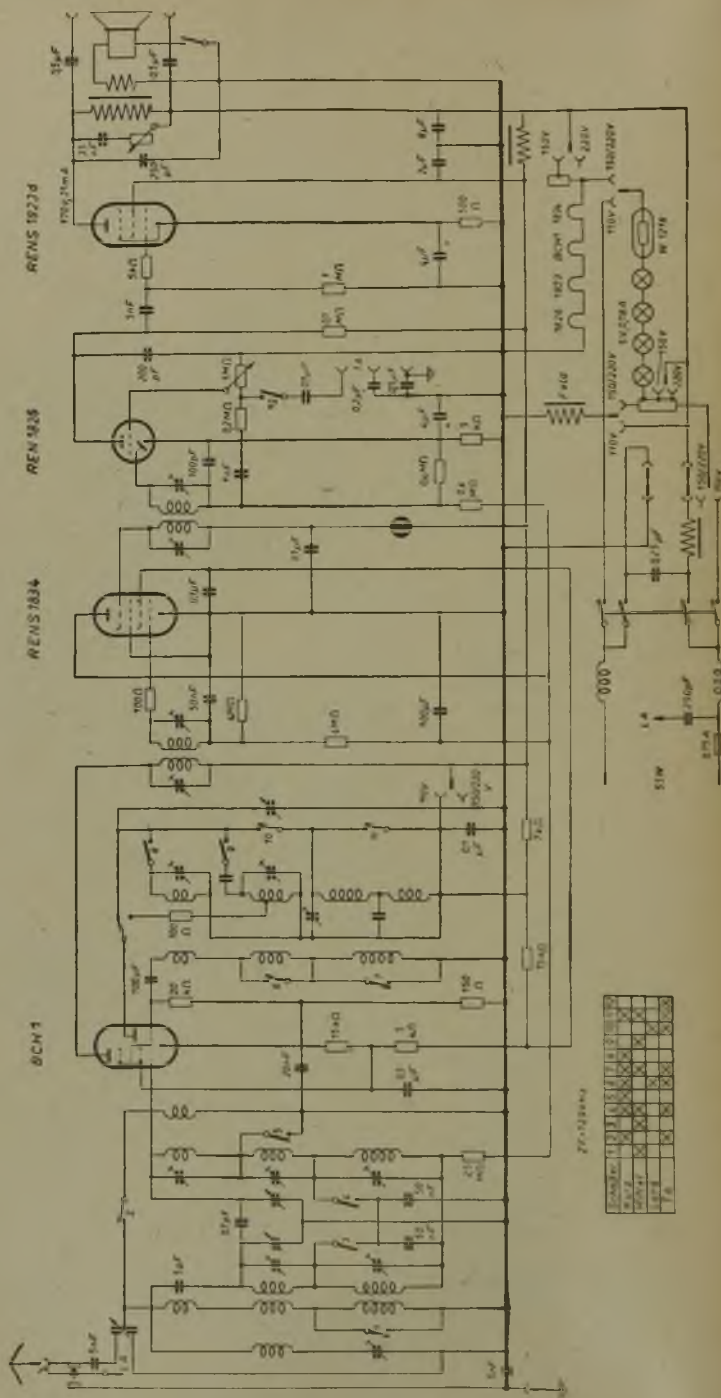

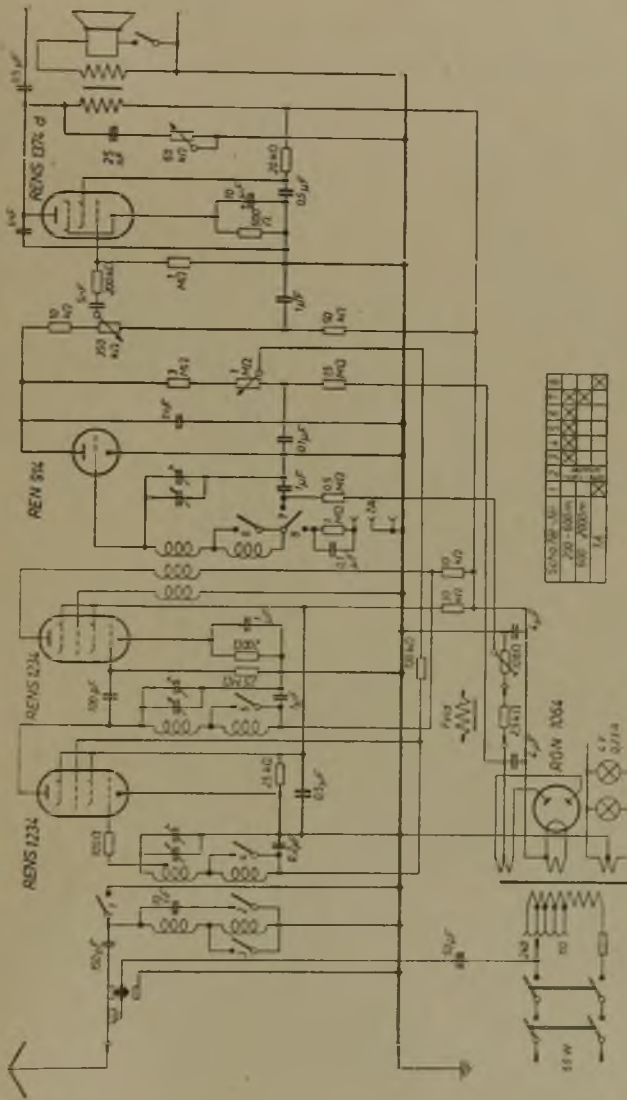

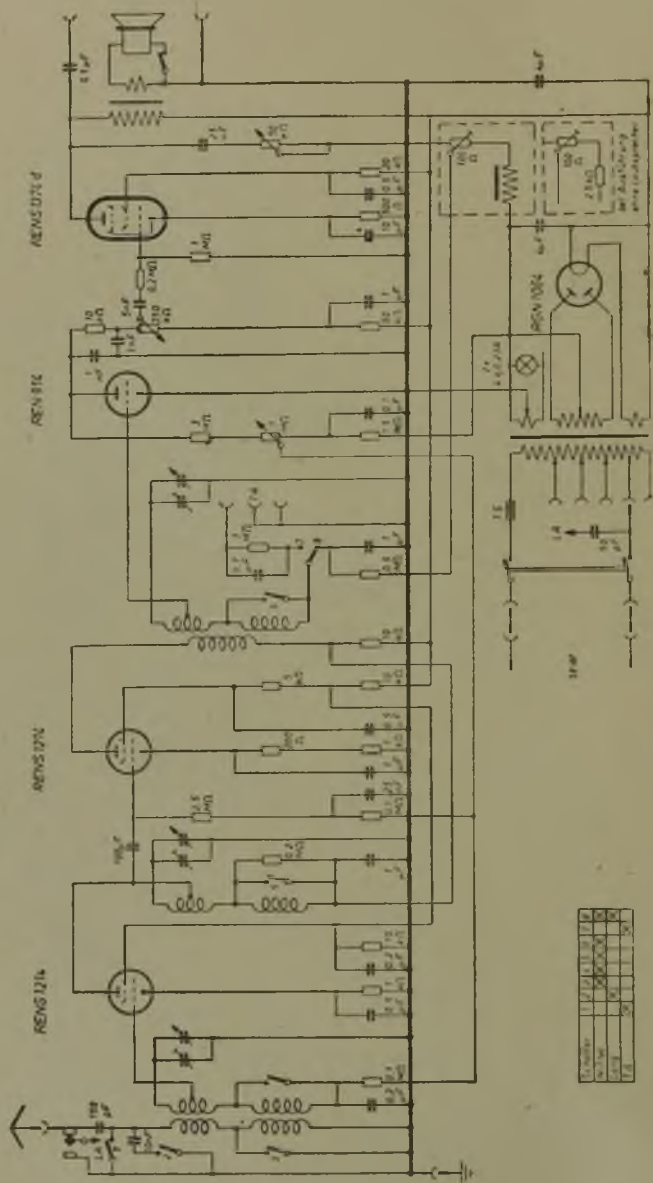

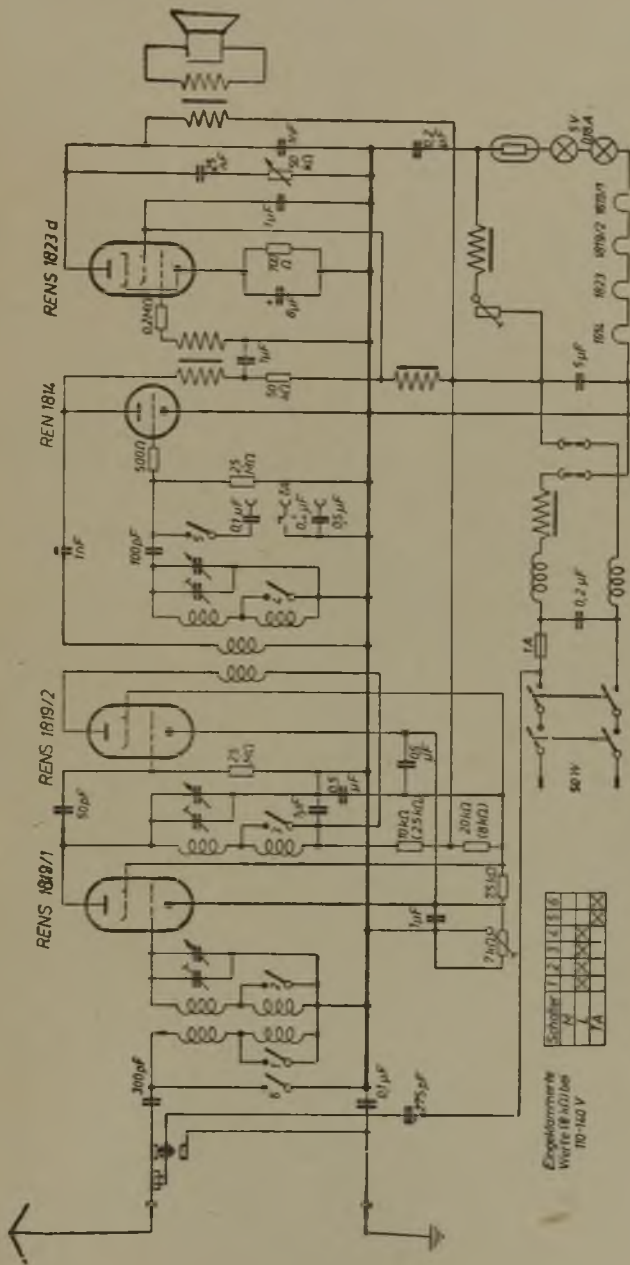

Schalter	1	2	3	4	5	6
A						
A						

Empfehlene Werte (8 MΩ/See 10-100 V)

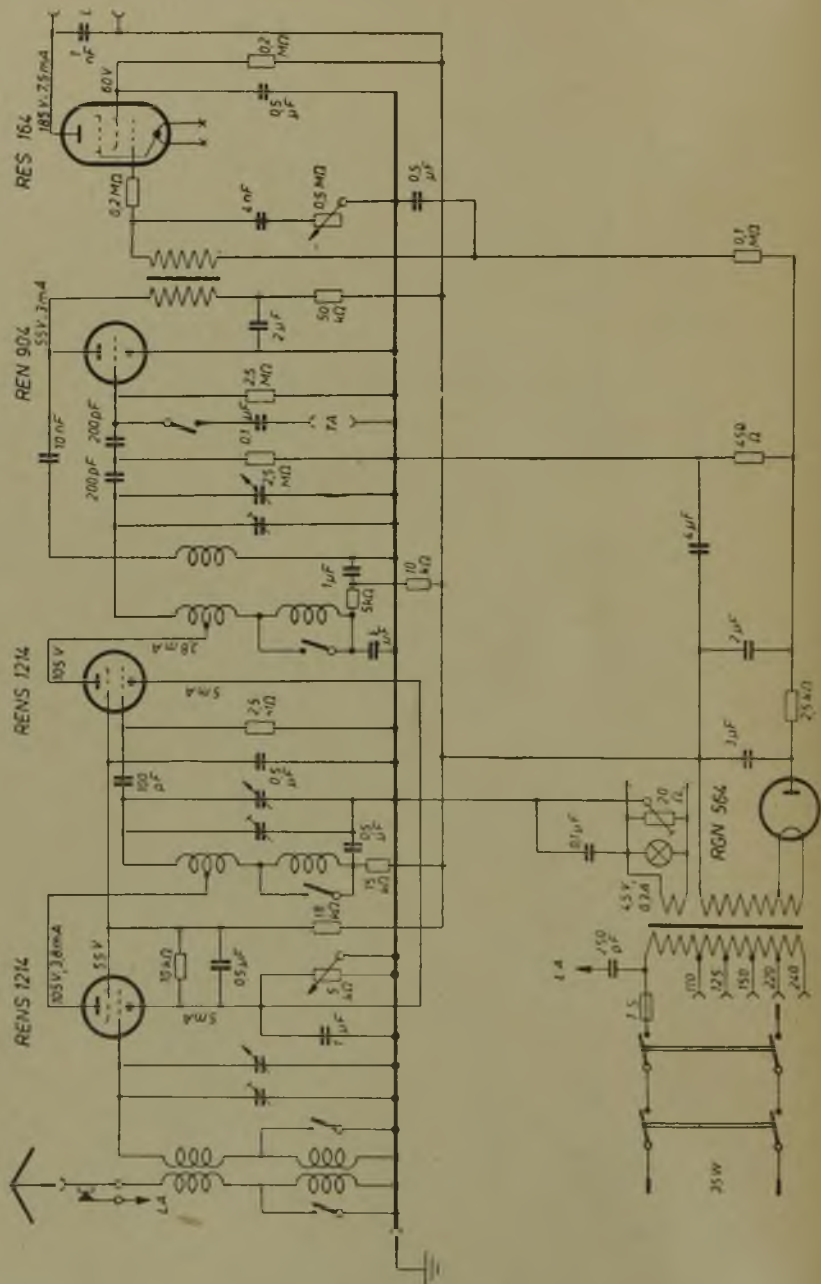

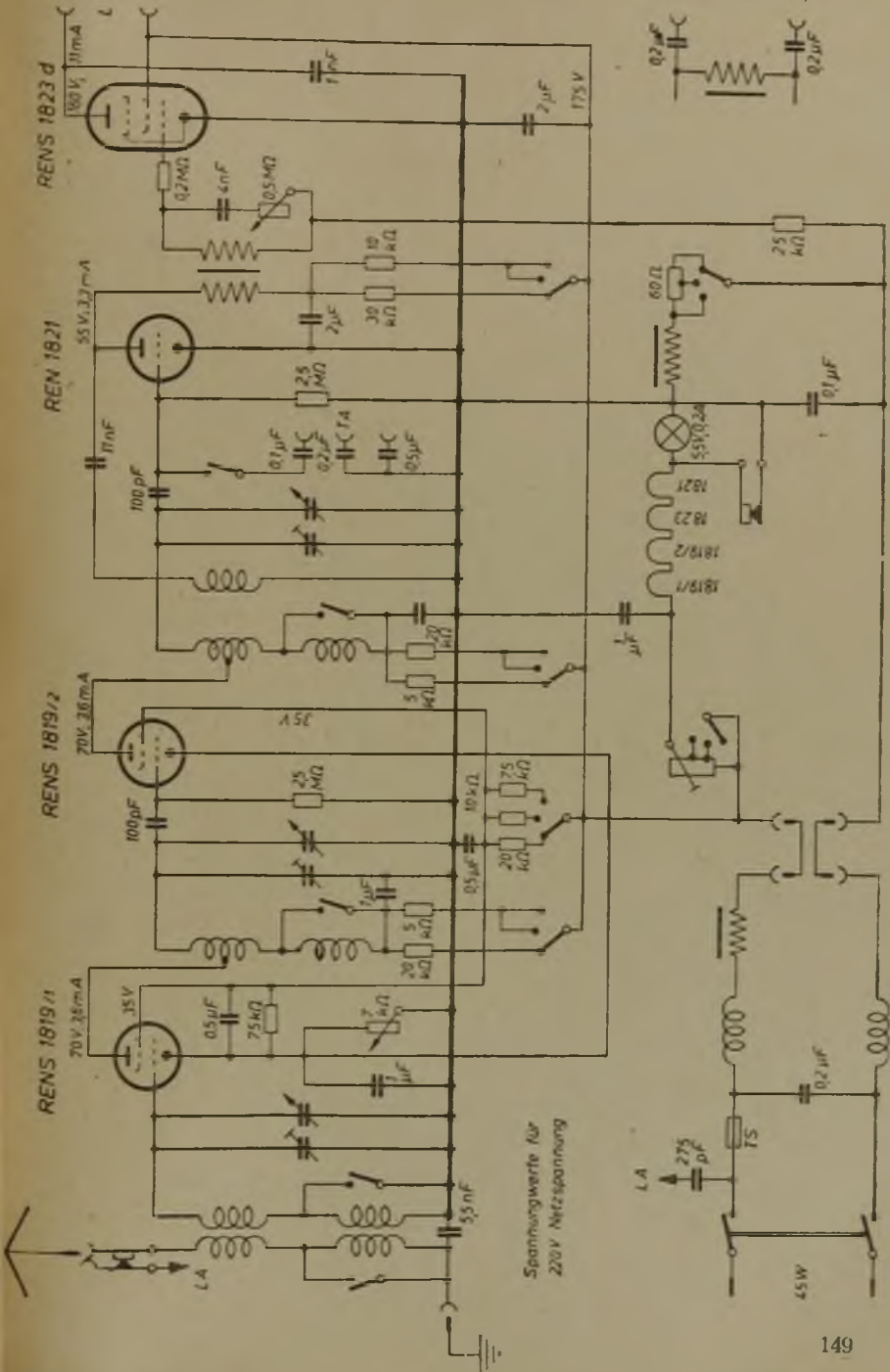

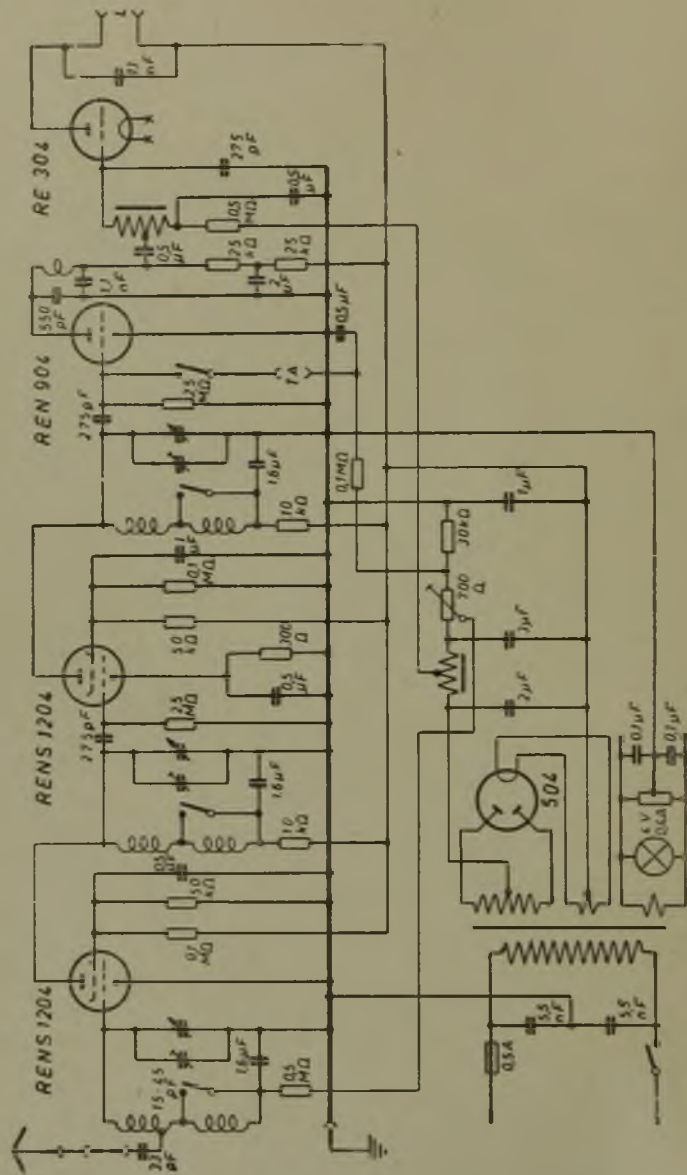

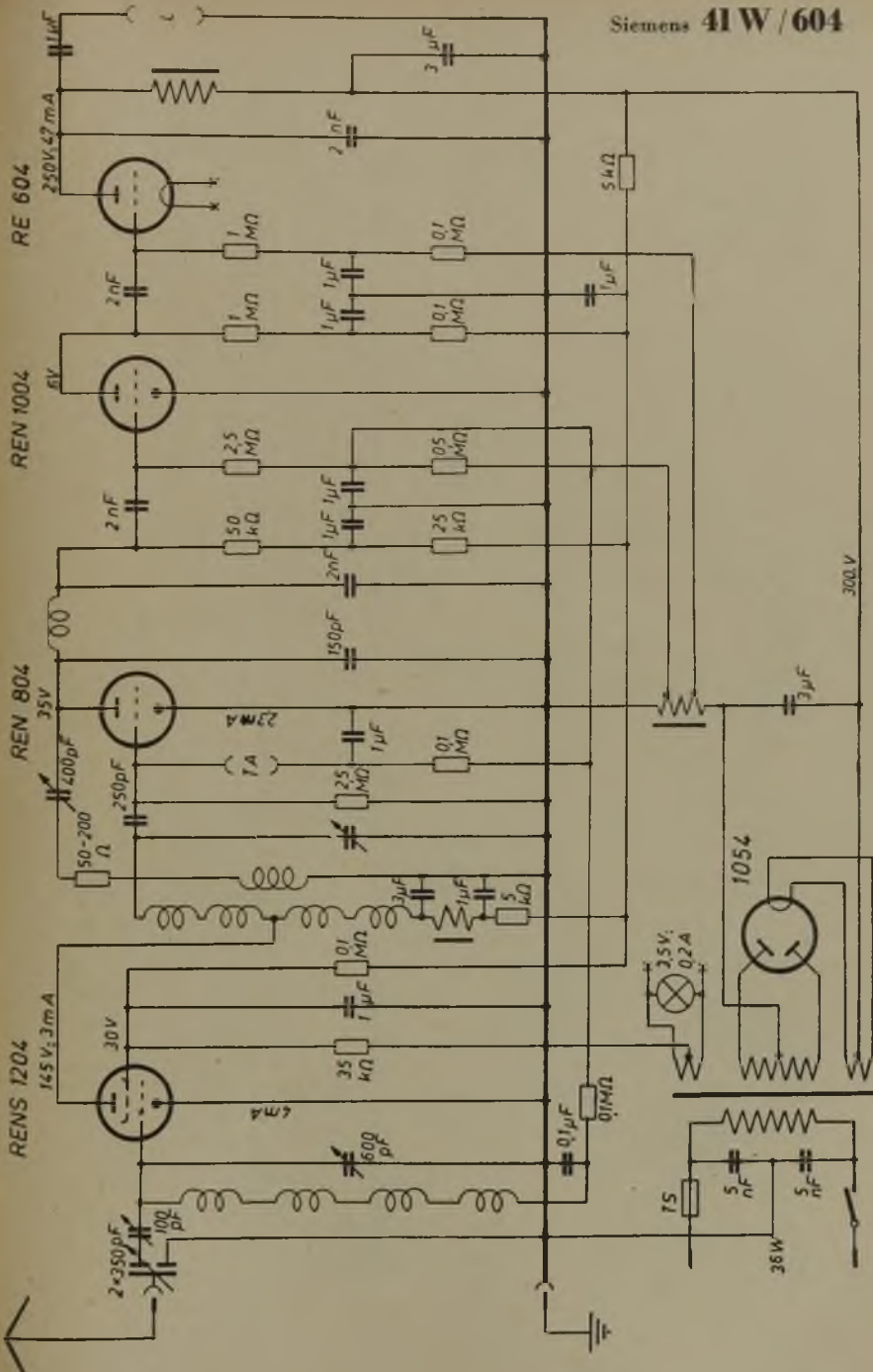

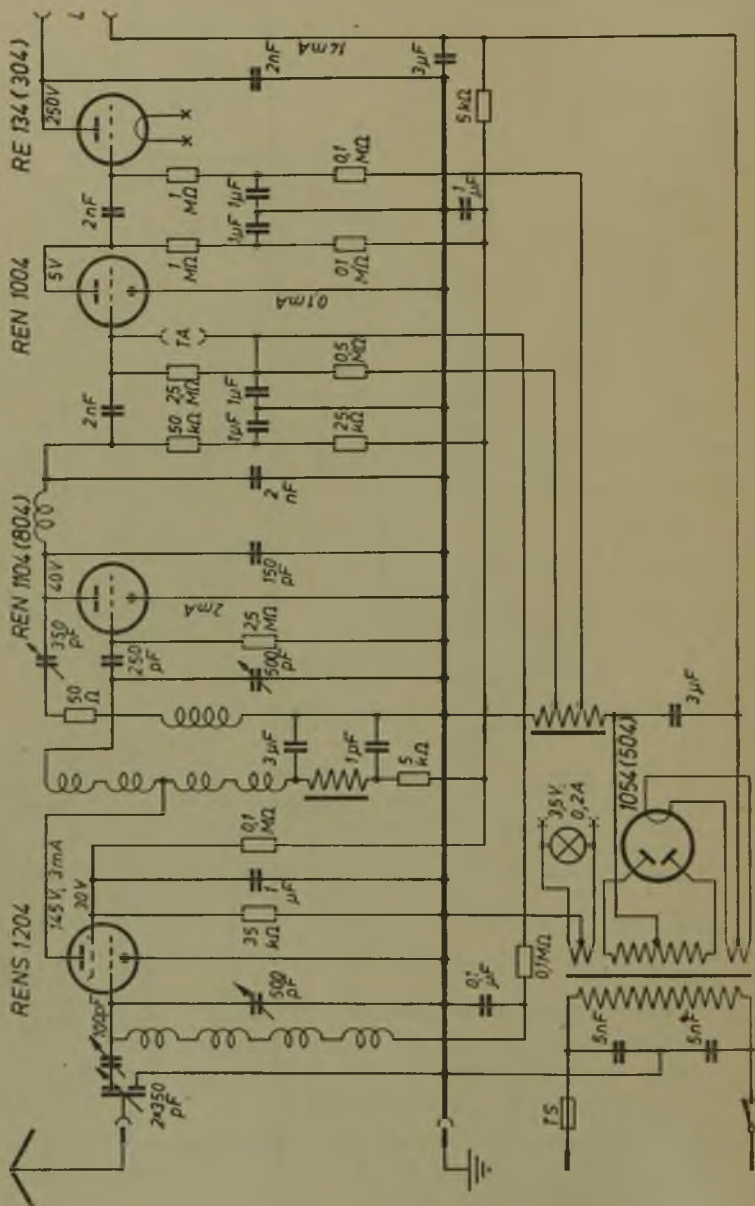

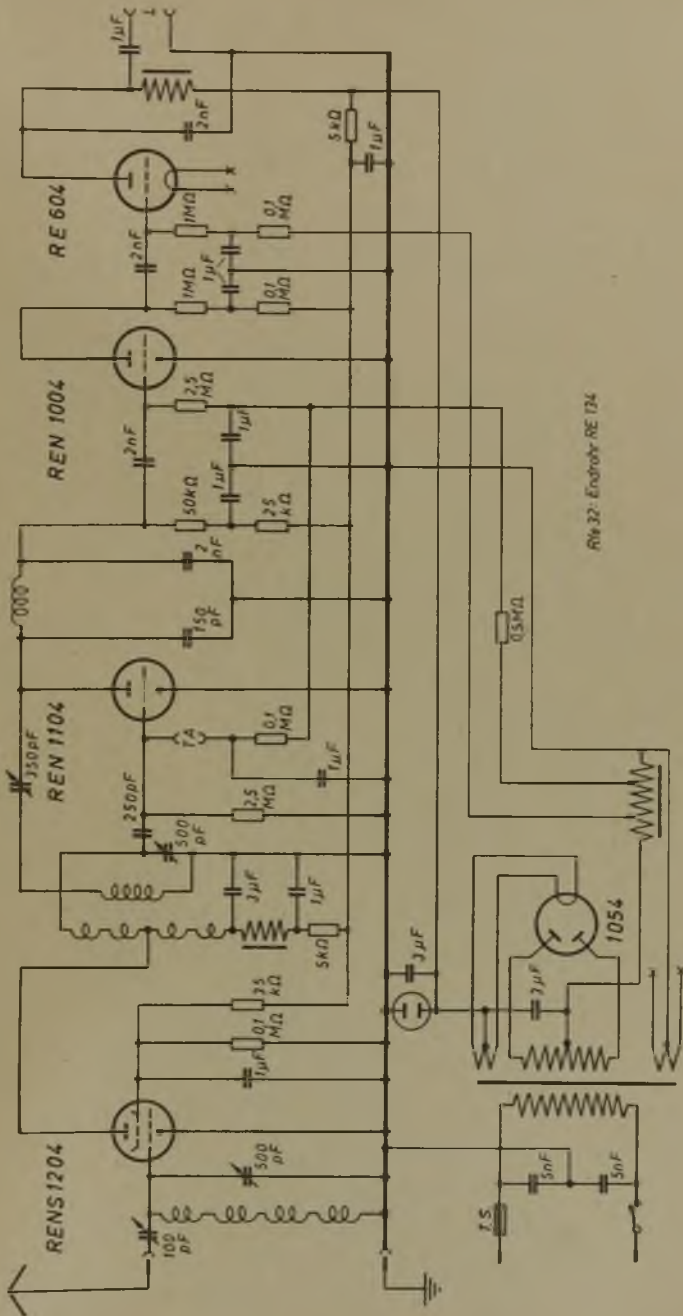

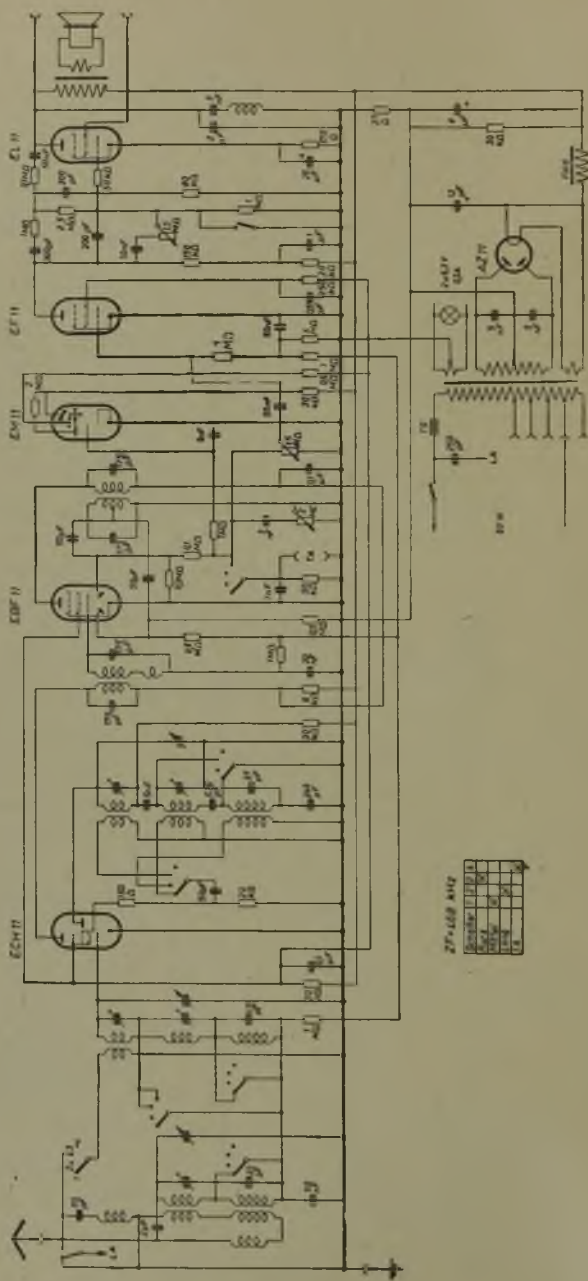

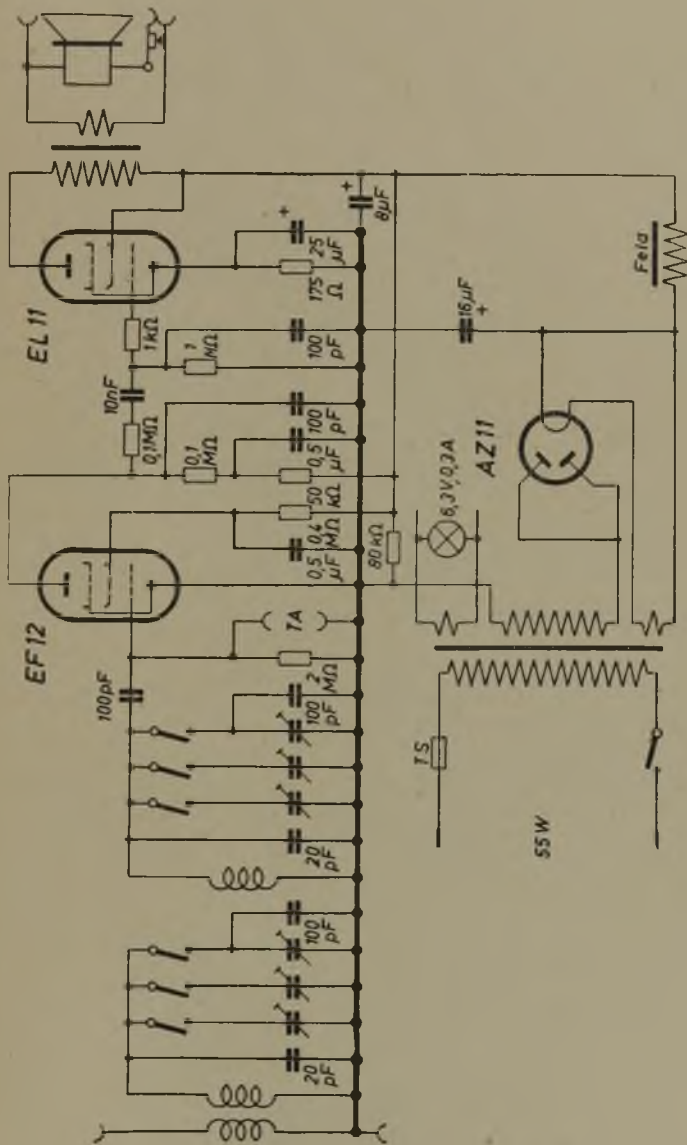

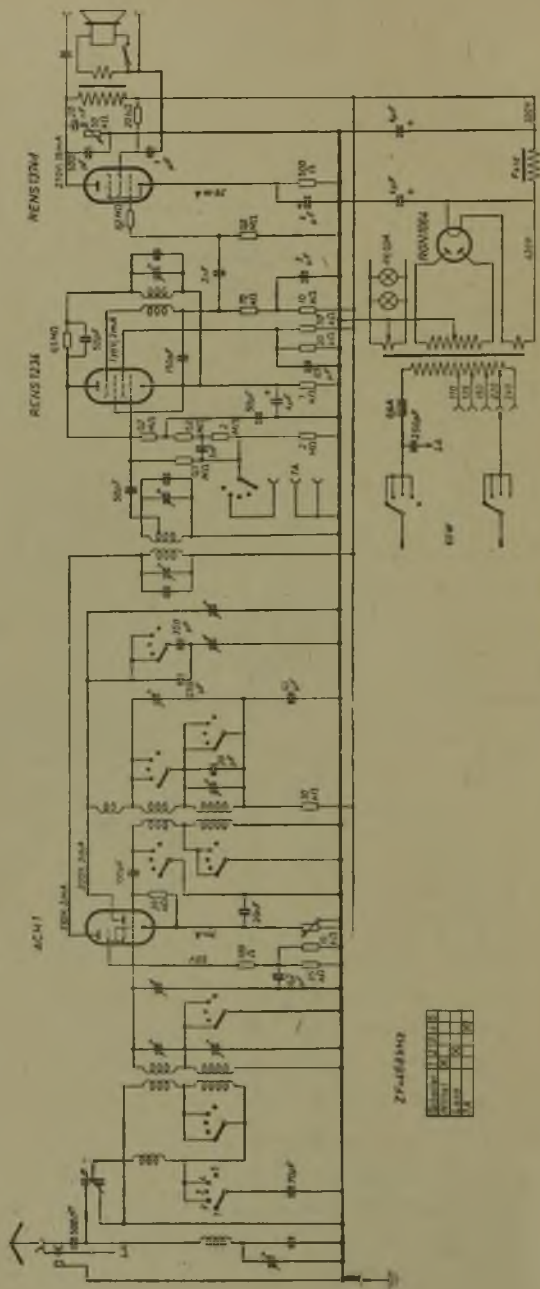

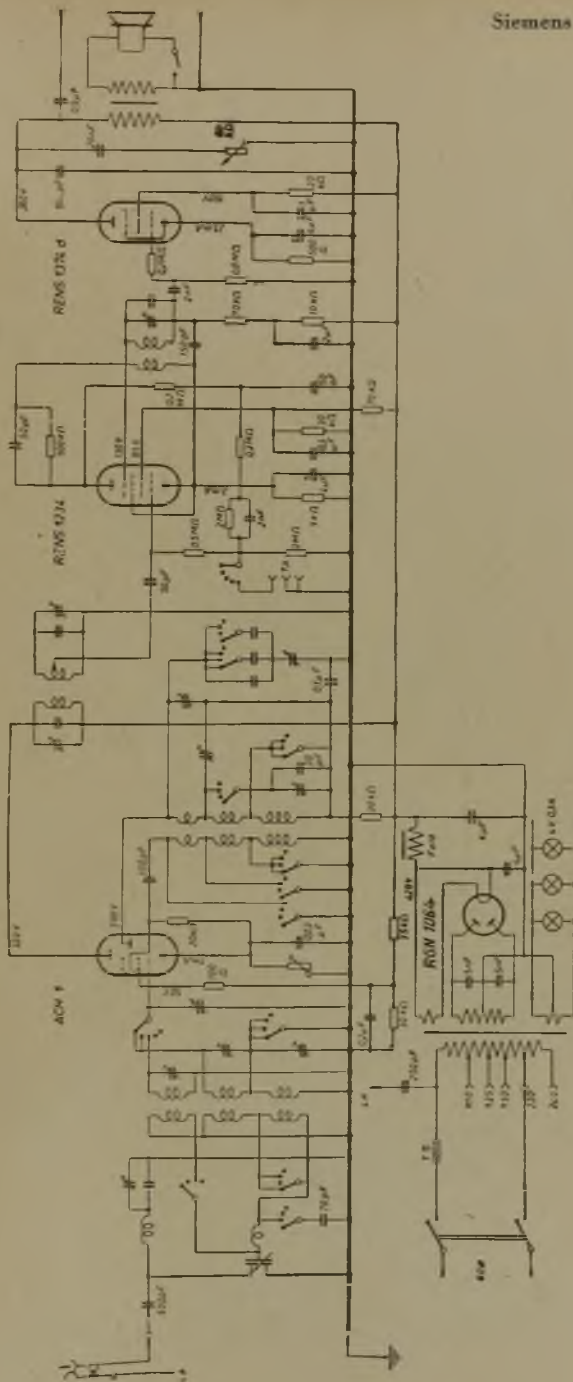

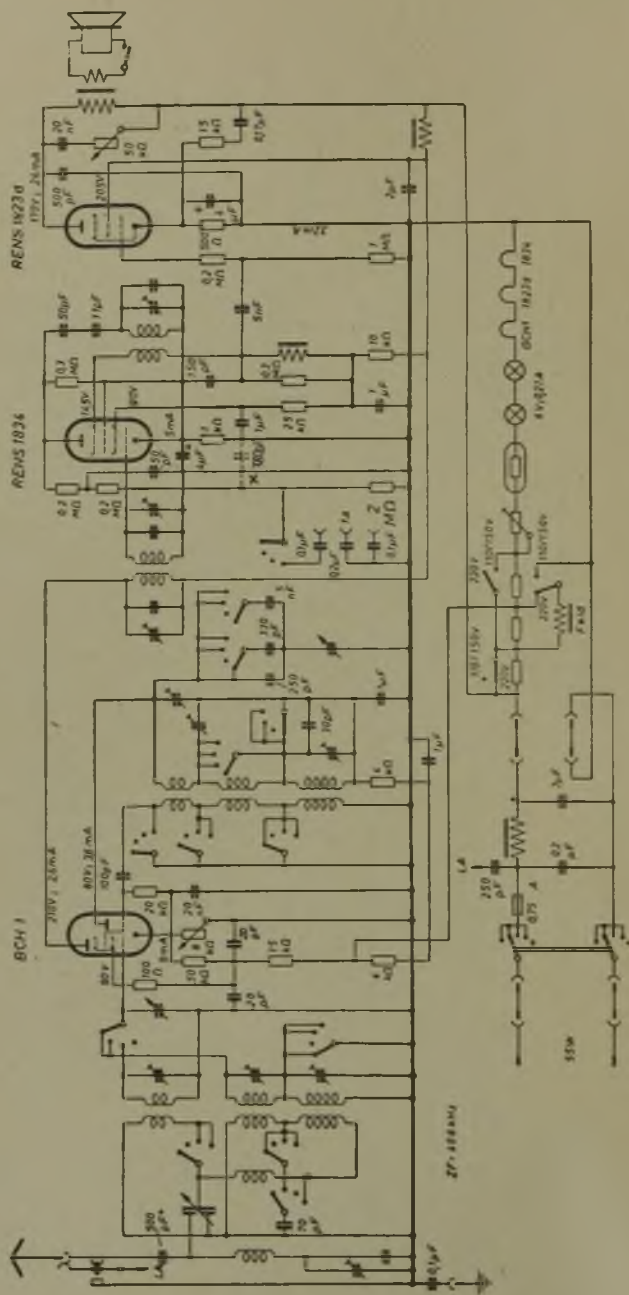

×) Kapazität der abgeschirmten Leitung, die den Kreis für die ZF erdet.

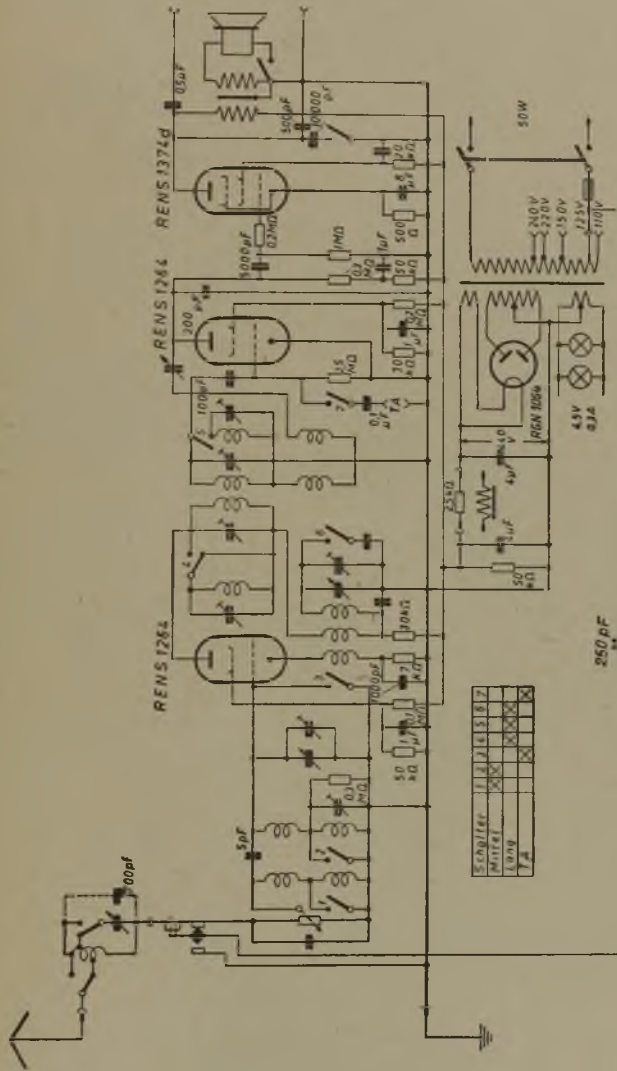

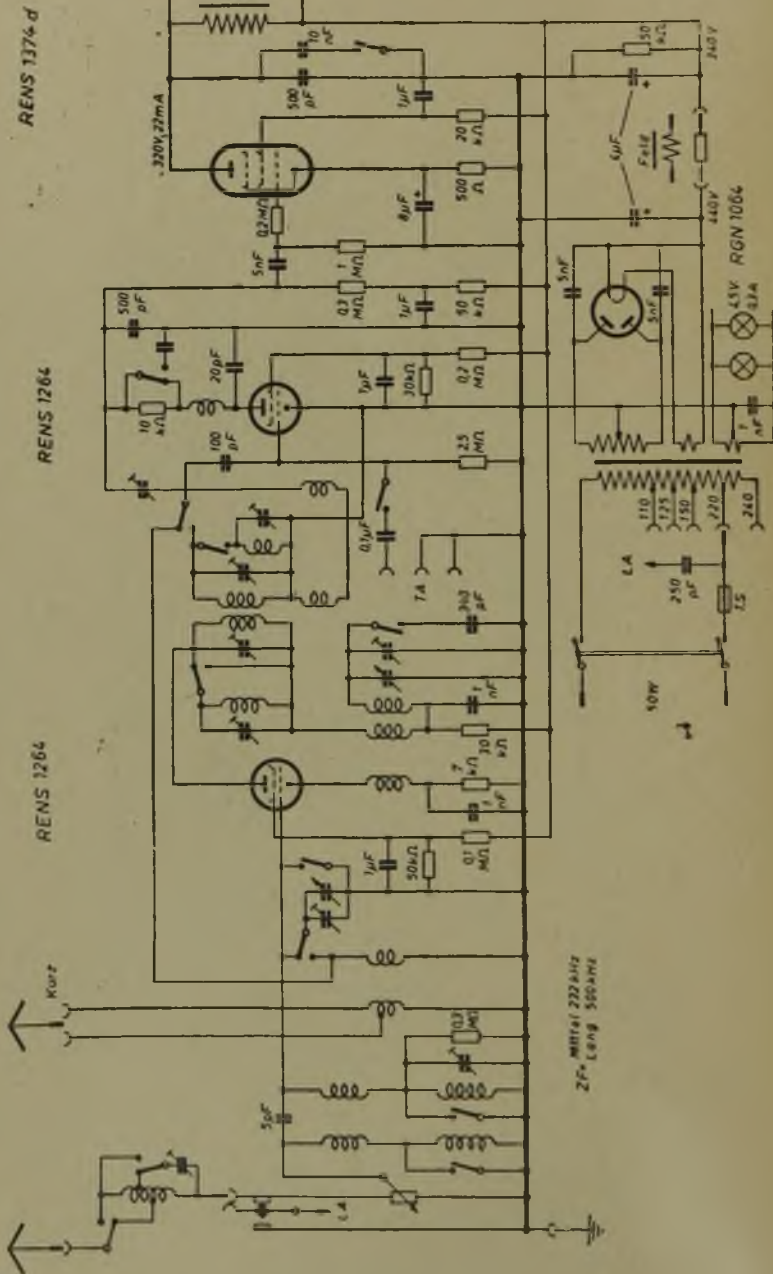

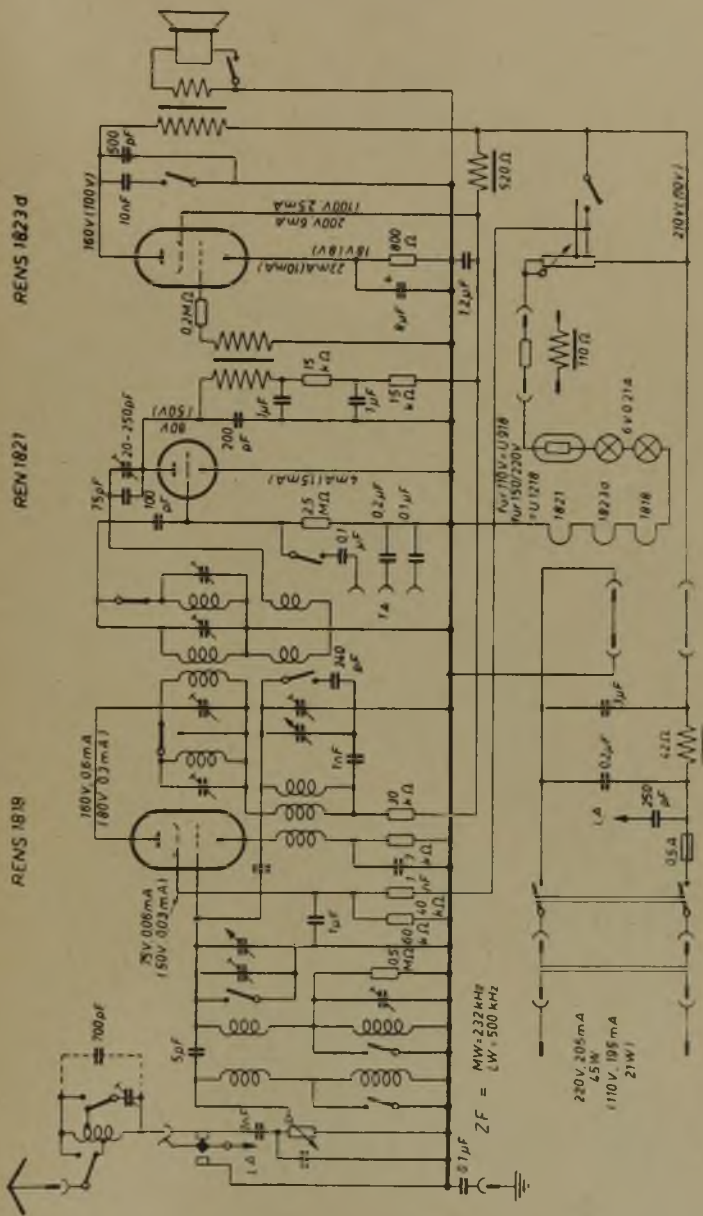

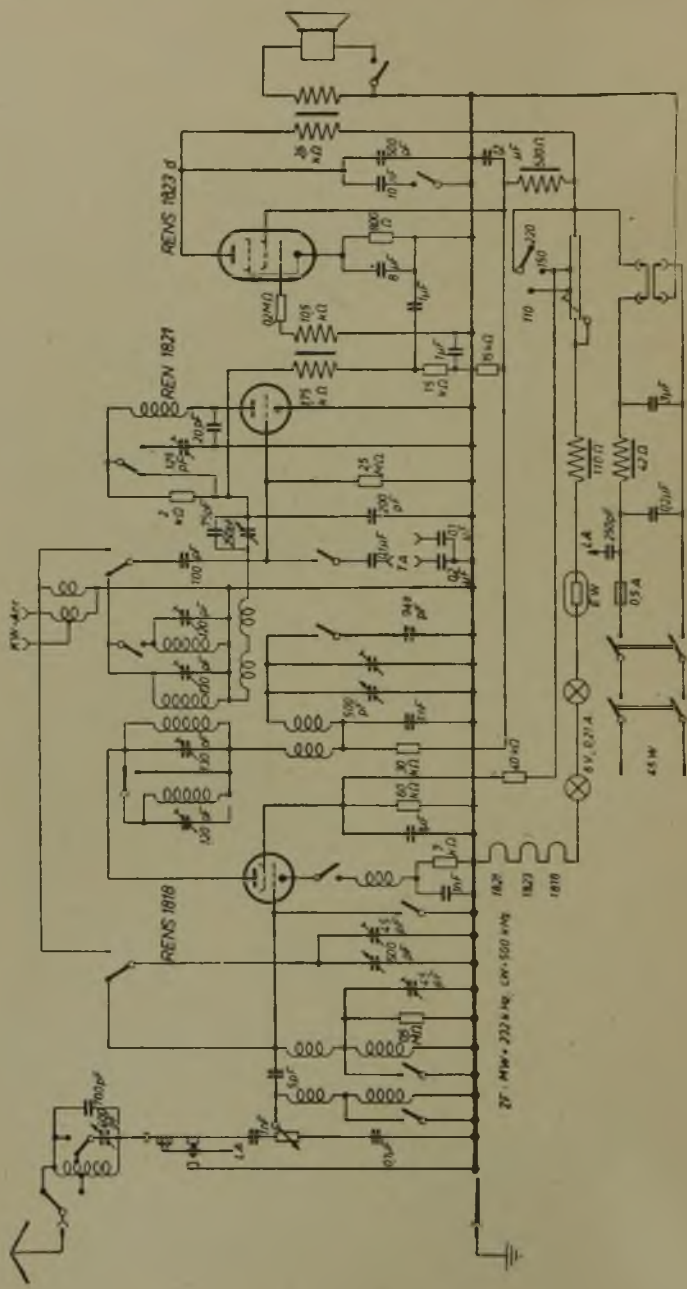

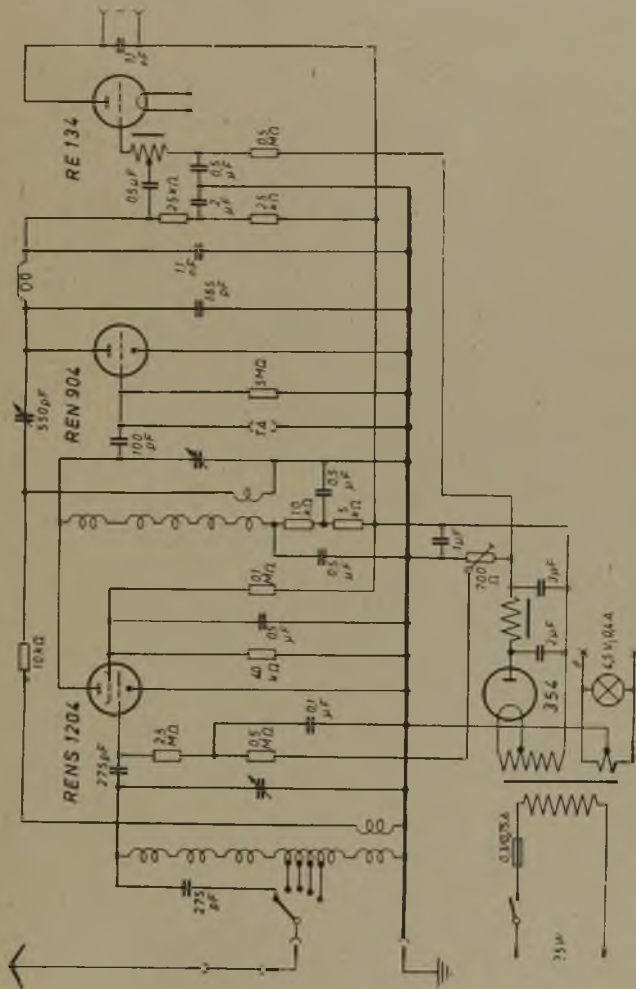

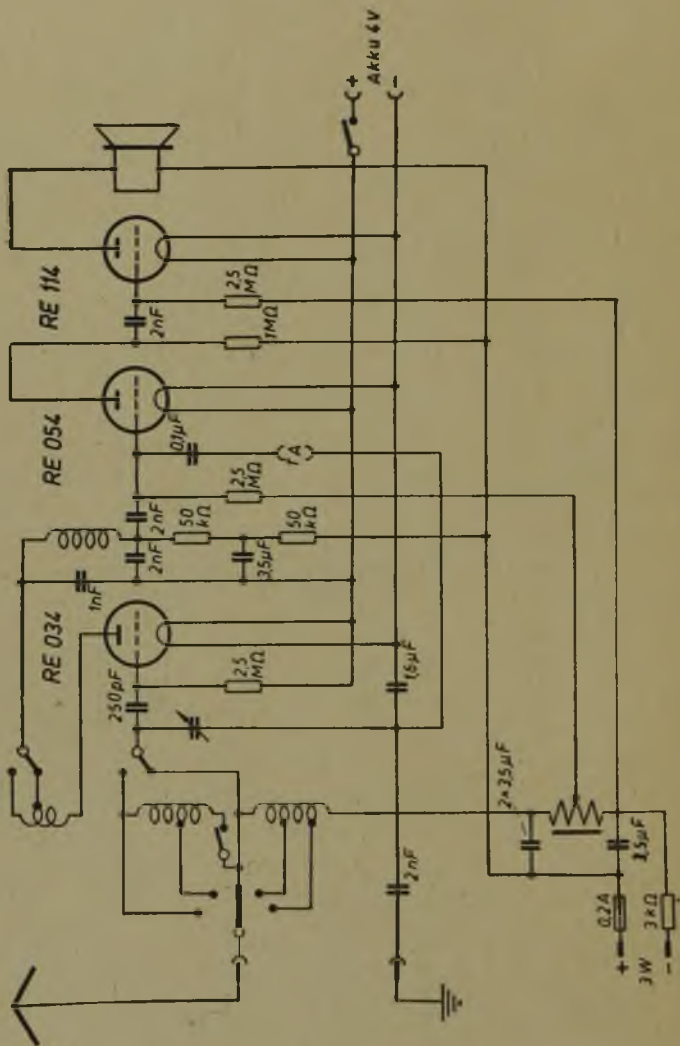

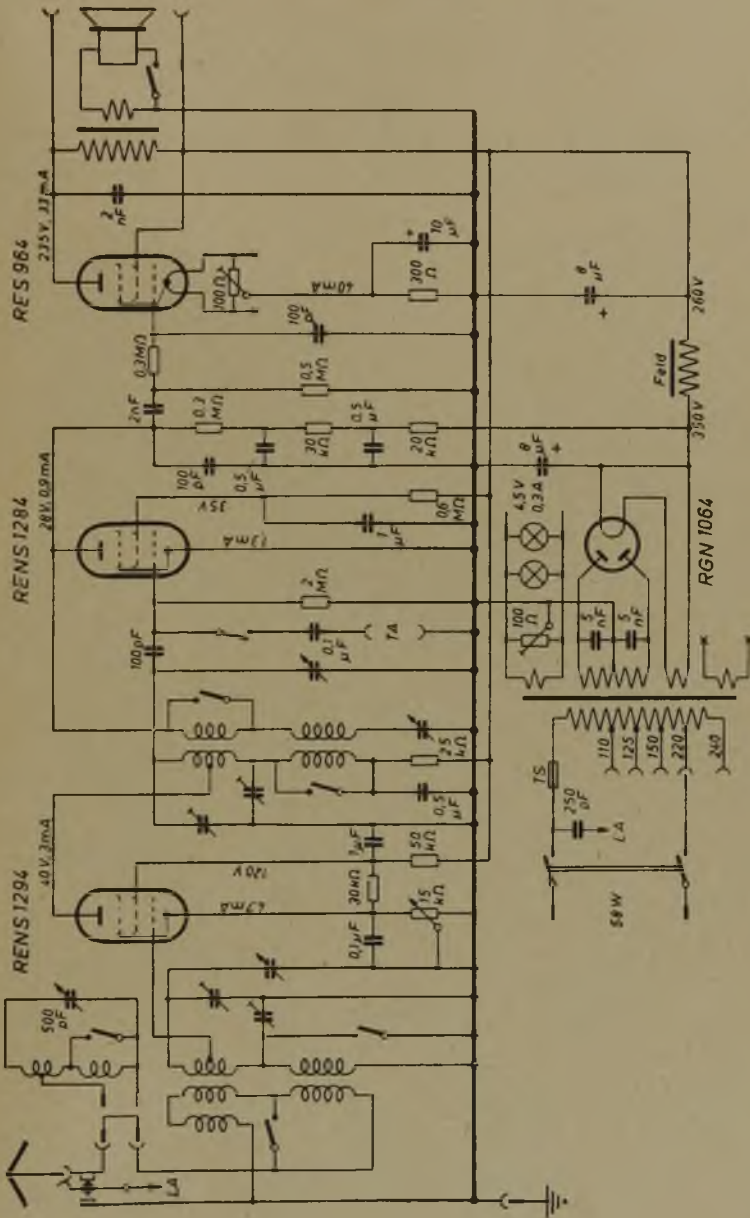

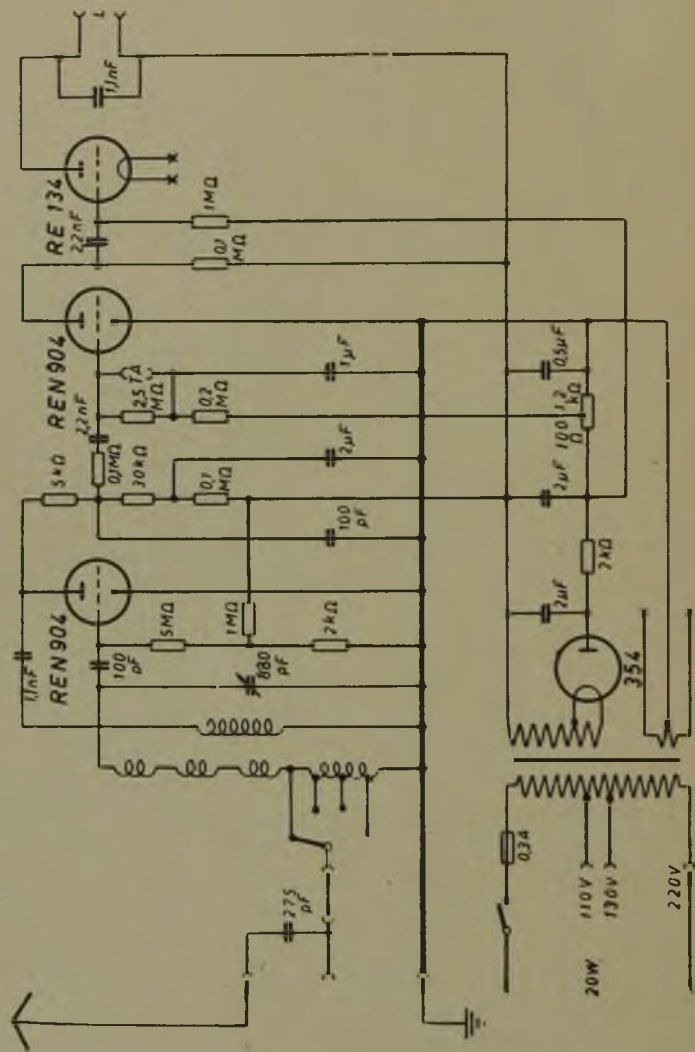

Siemens K 32 GWB

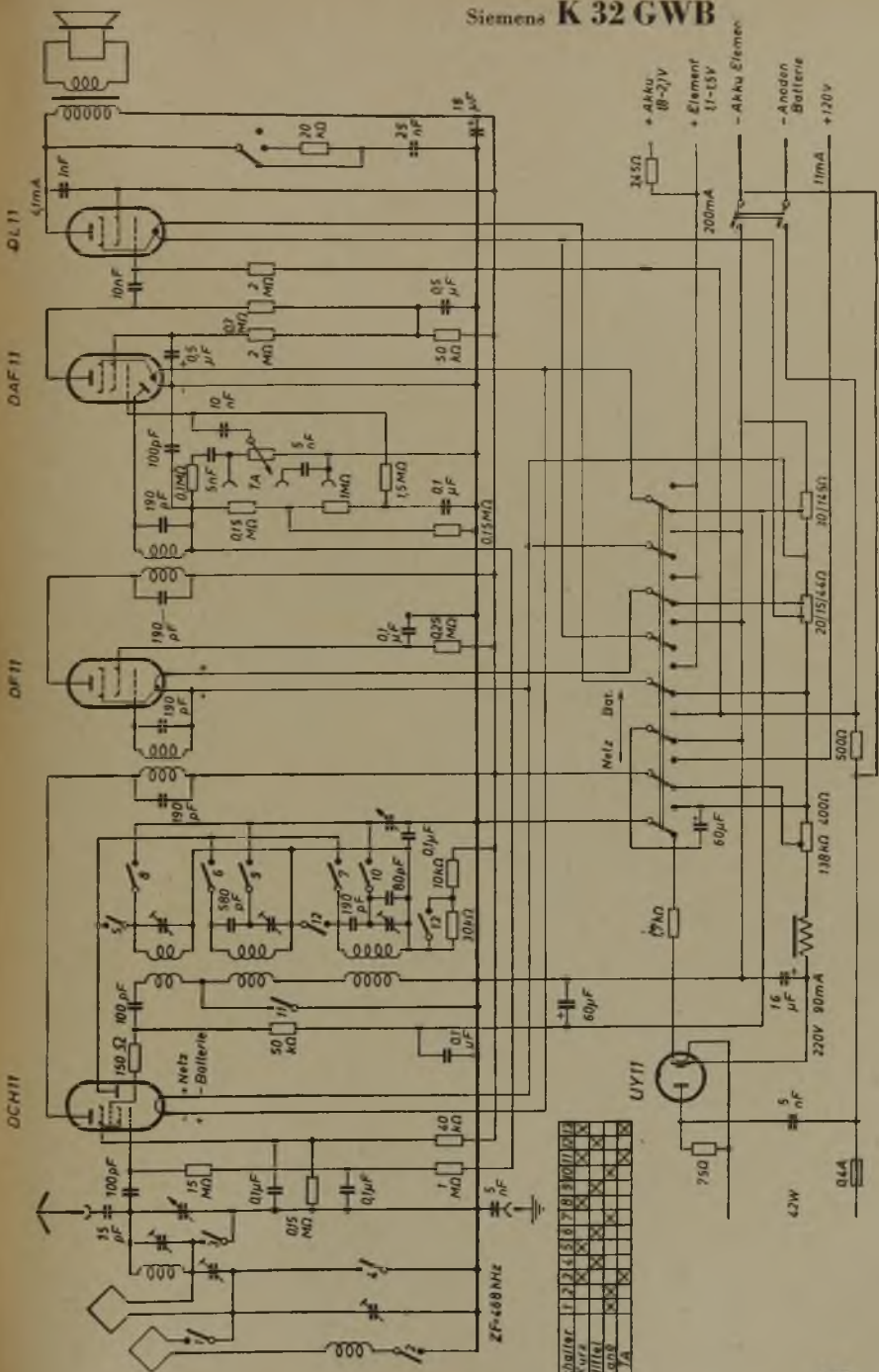

Schalter	1	2	3	4	5	6	7	8	9	10	11	12
Kurz	X	X	X	X	X	X	X	X	X	X	X	X
Mittel	X	X	X	X	X	X	X	X	X	X	X	X
Lang	X	X	X	X	X	X	X	X	X	X	X	X
JA												

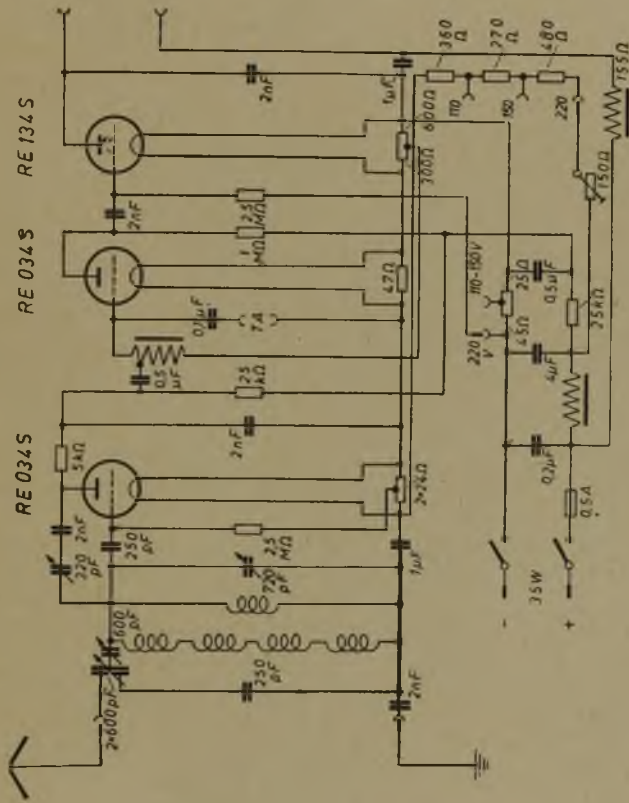

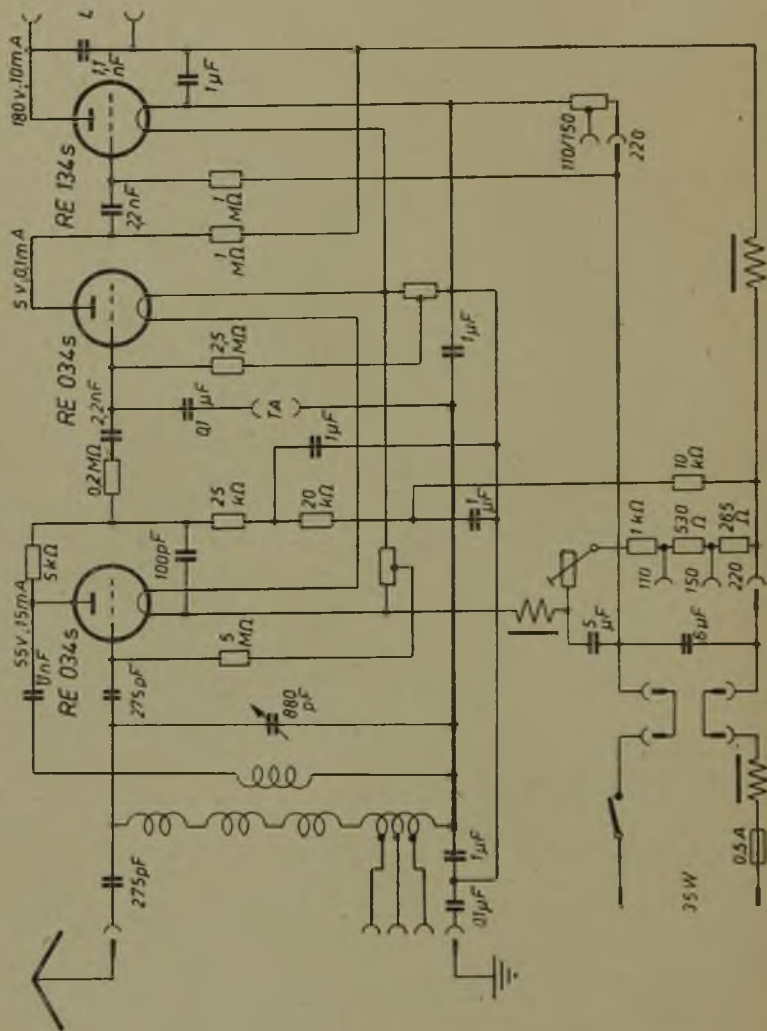

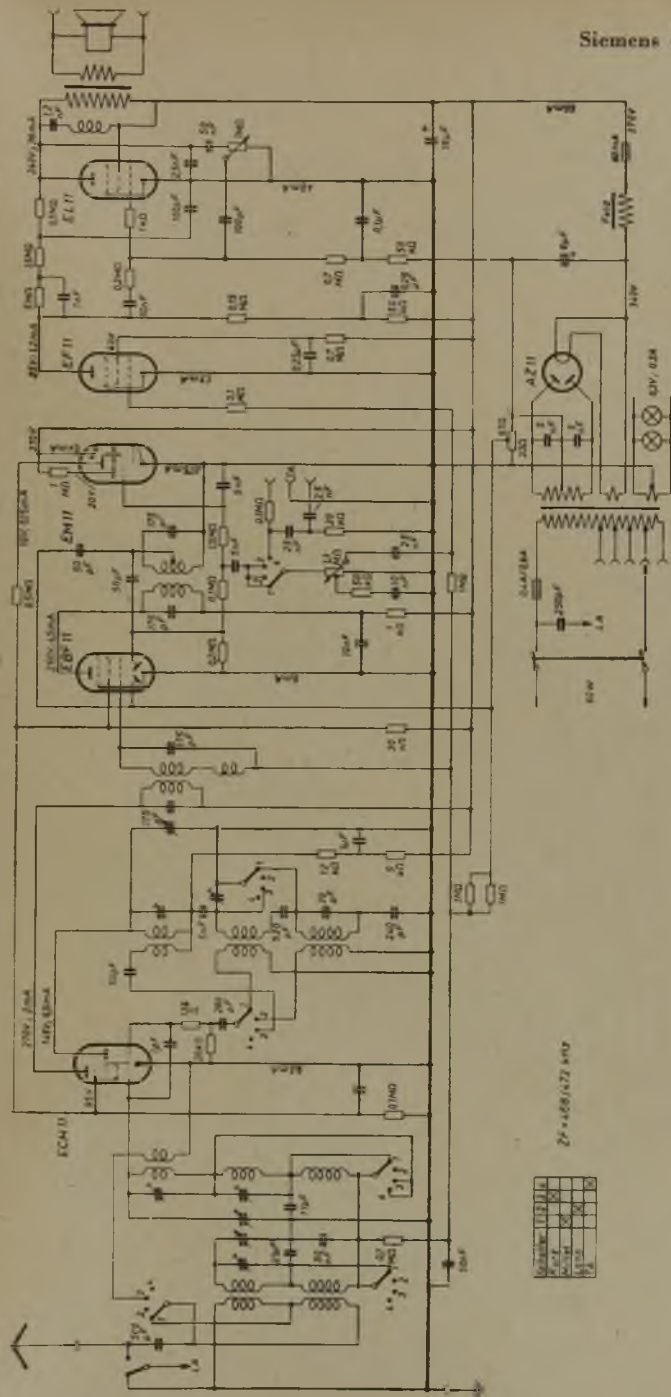

25 + 250 (27) 8V2

6X4	6Z5	6AV6	6BE6
6X4	6Z5	6AV6	6BE6
6X4	6Z5	6AV6	6BE6
6X4	6Z5	6AV6	6BE6

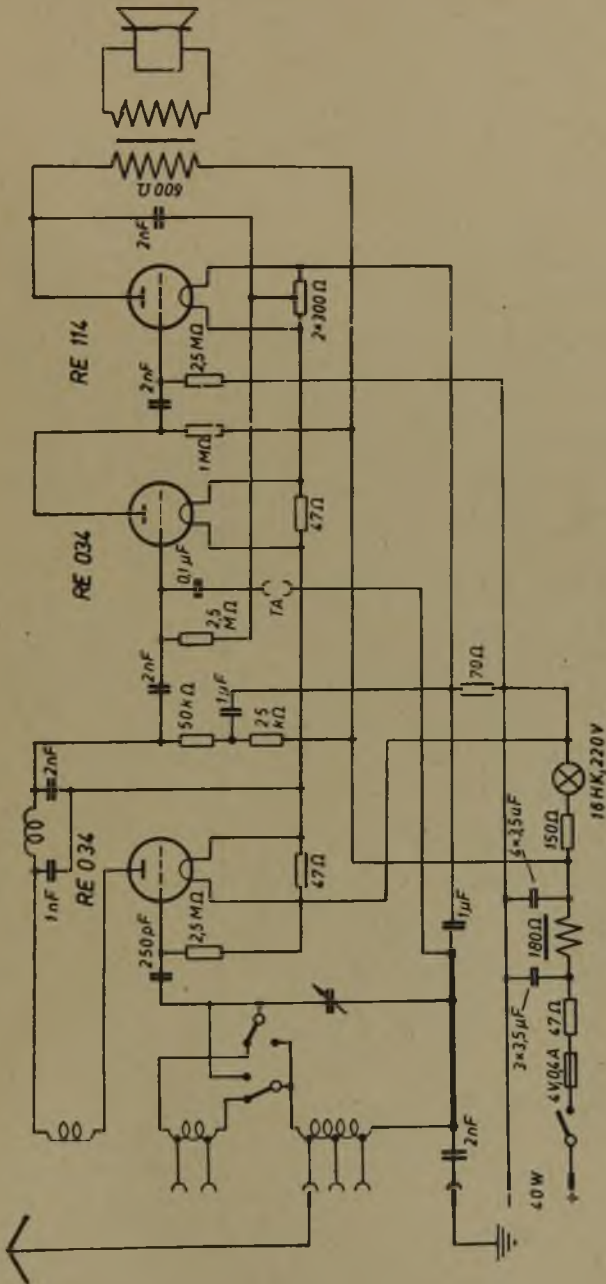

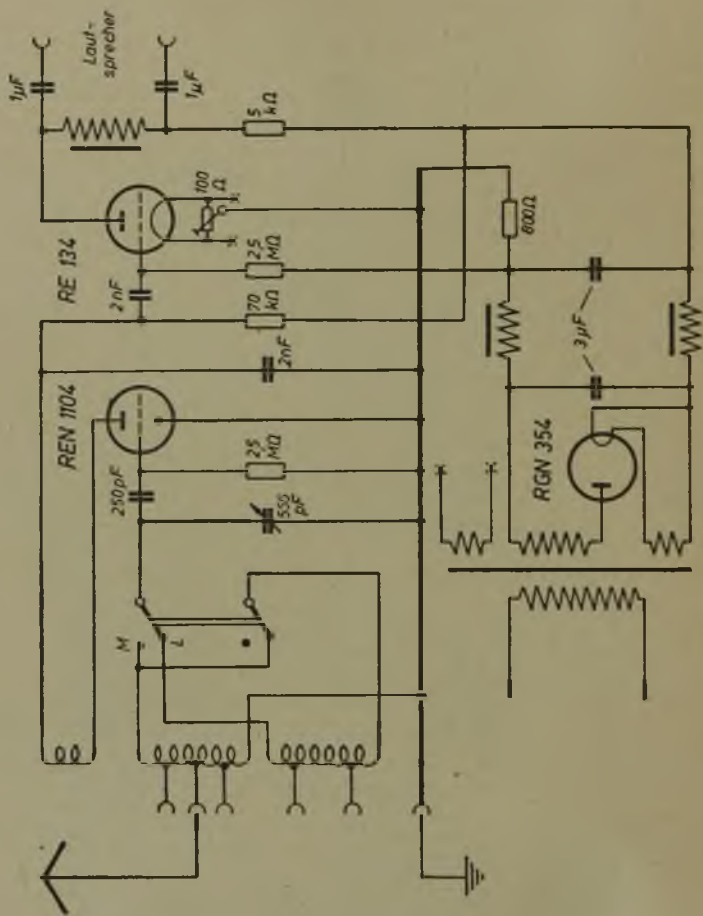

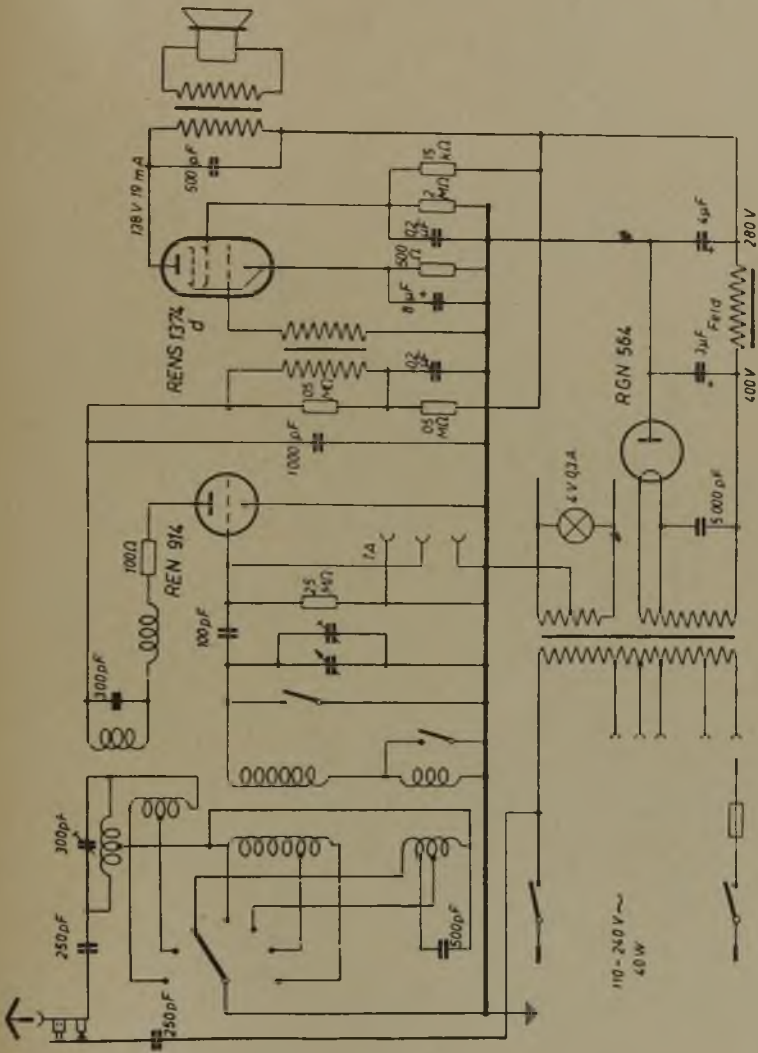

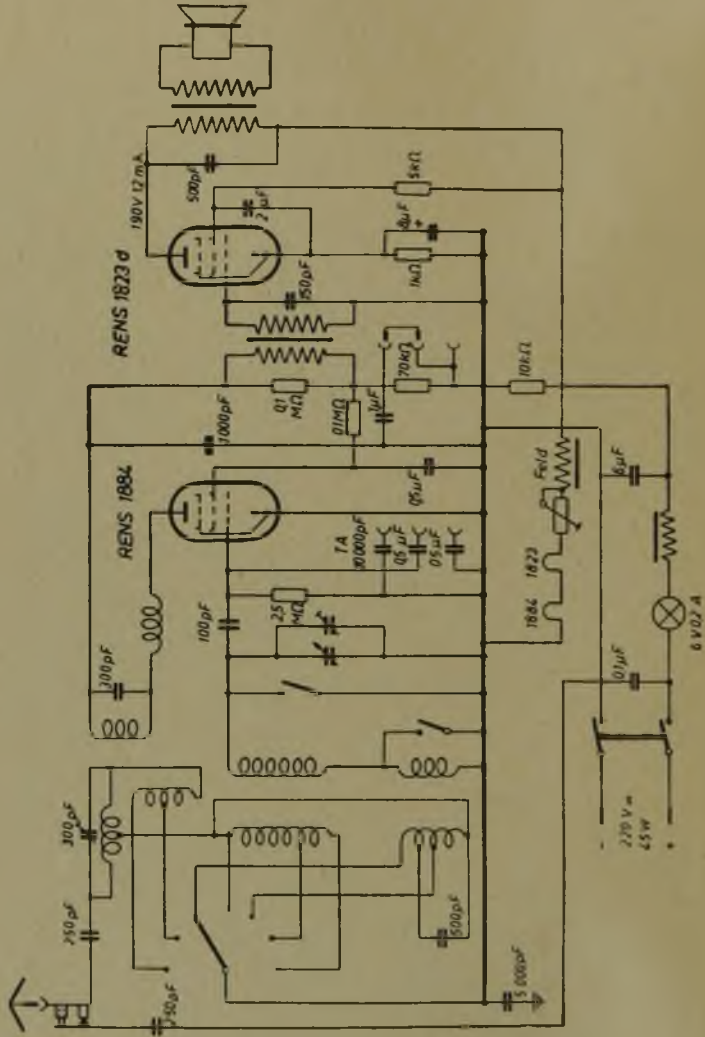

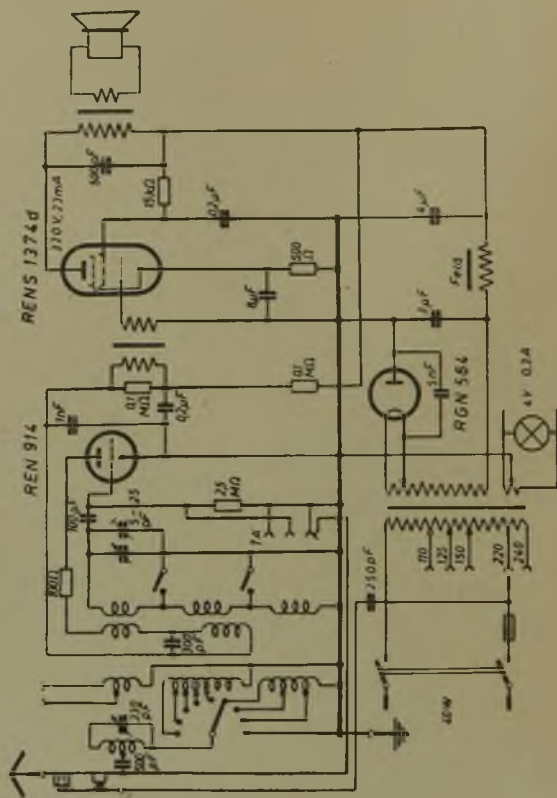

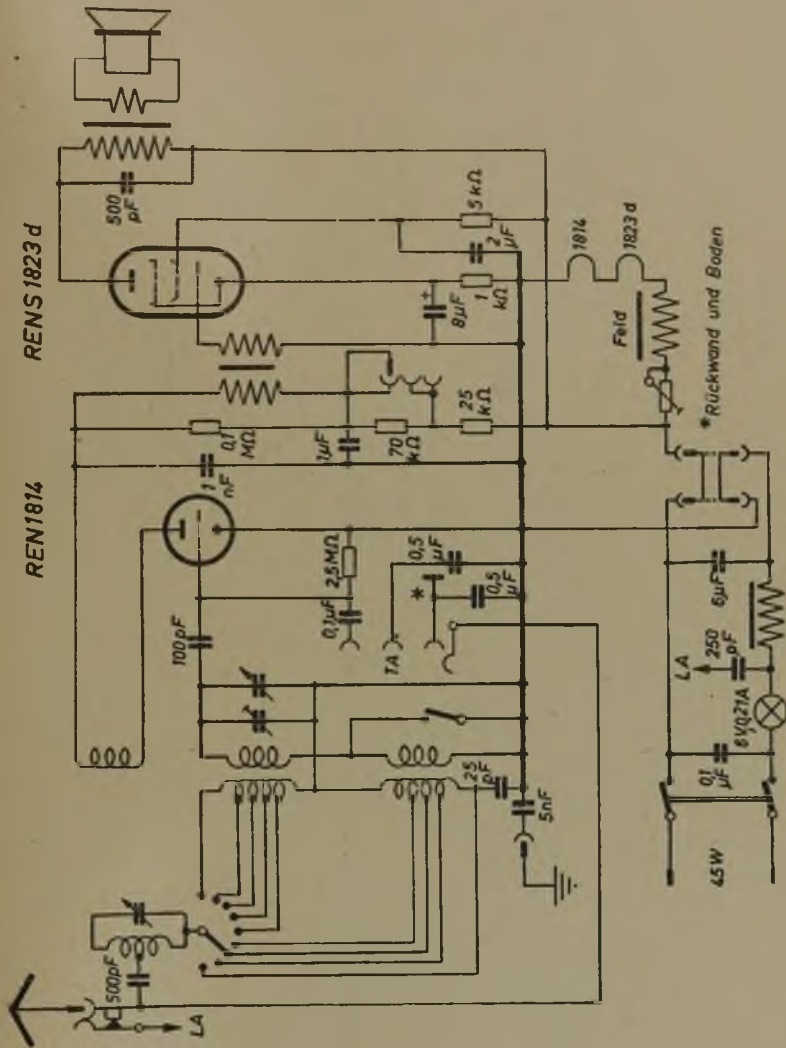

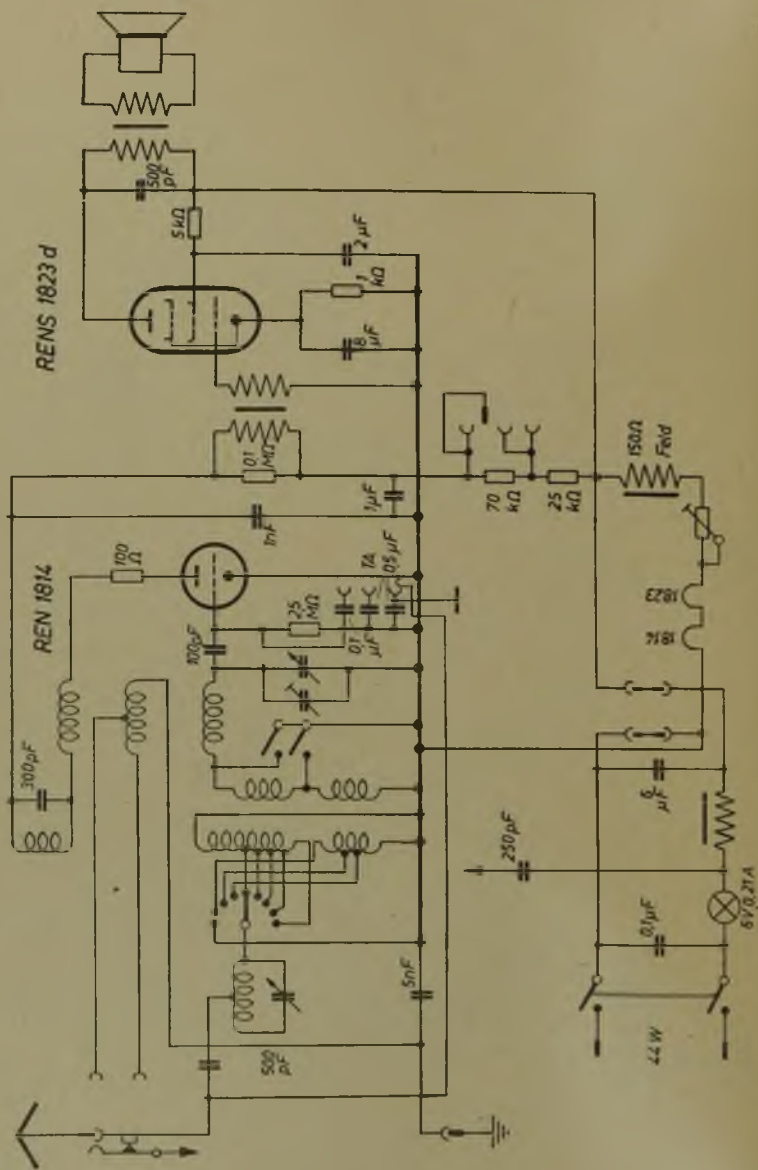

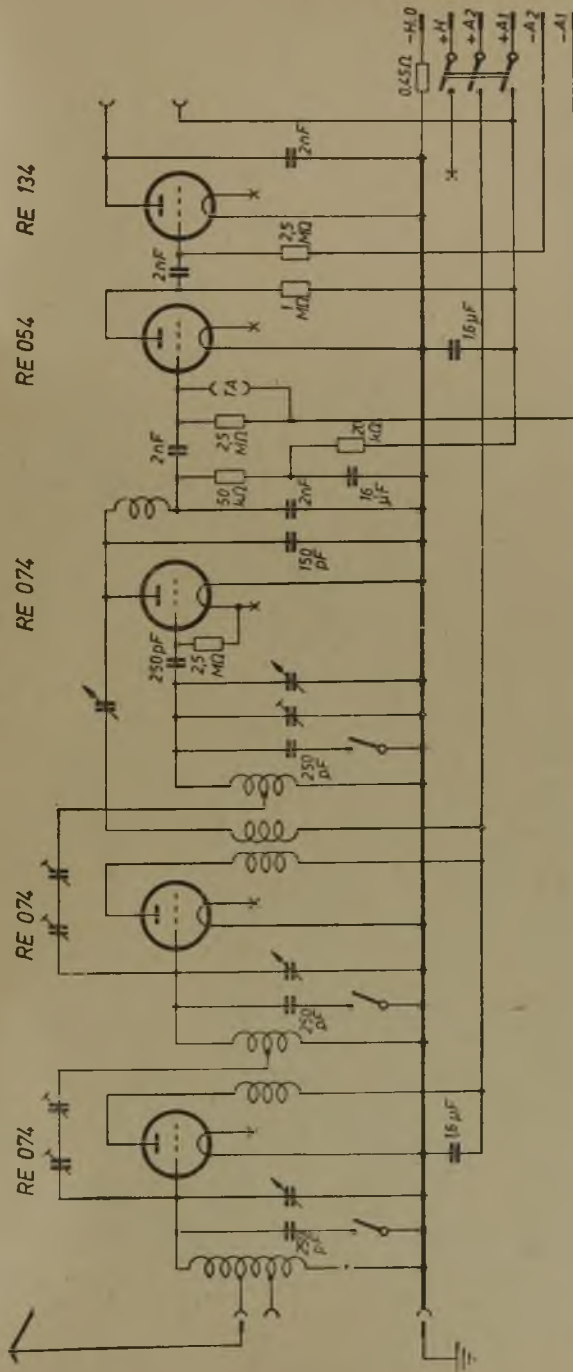

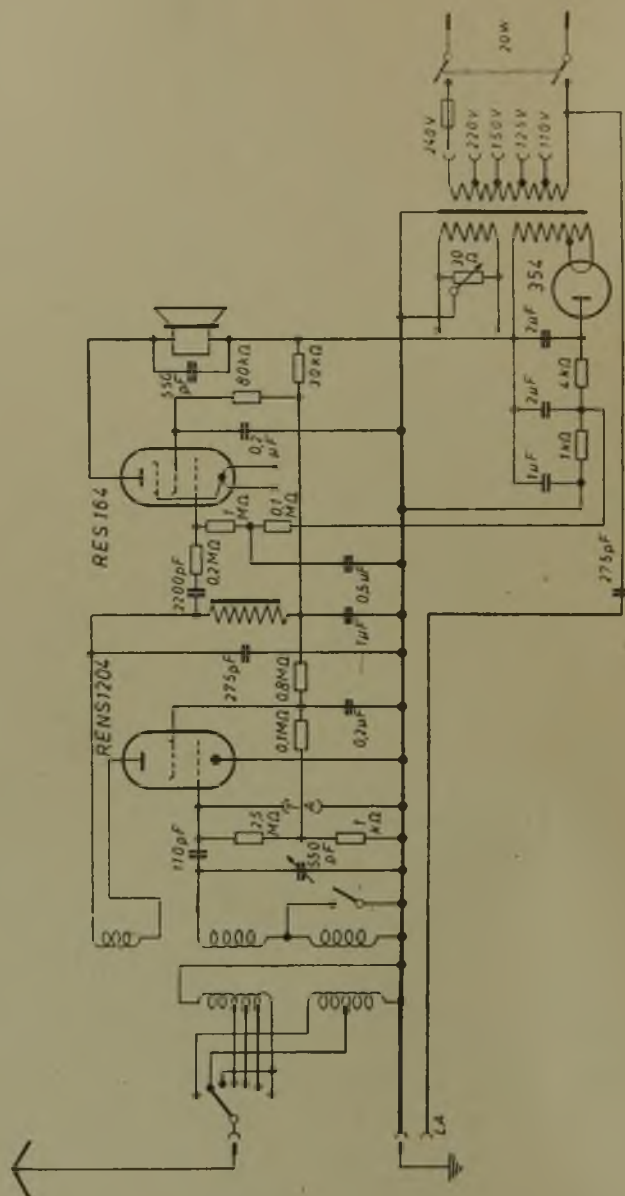

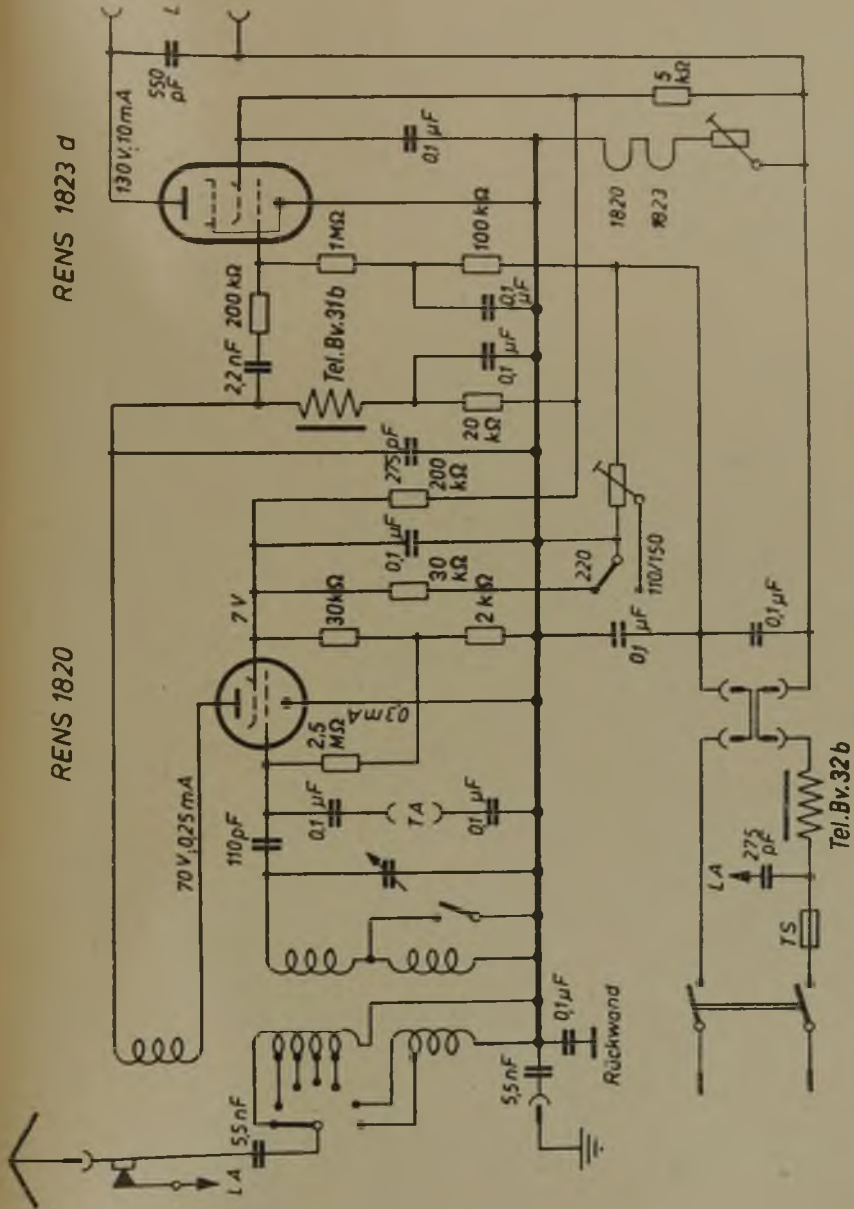

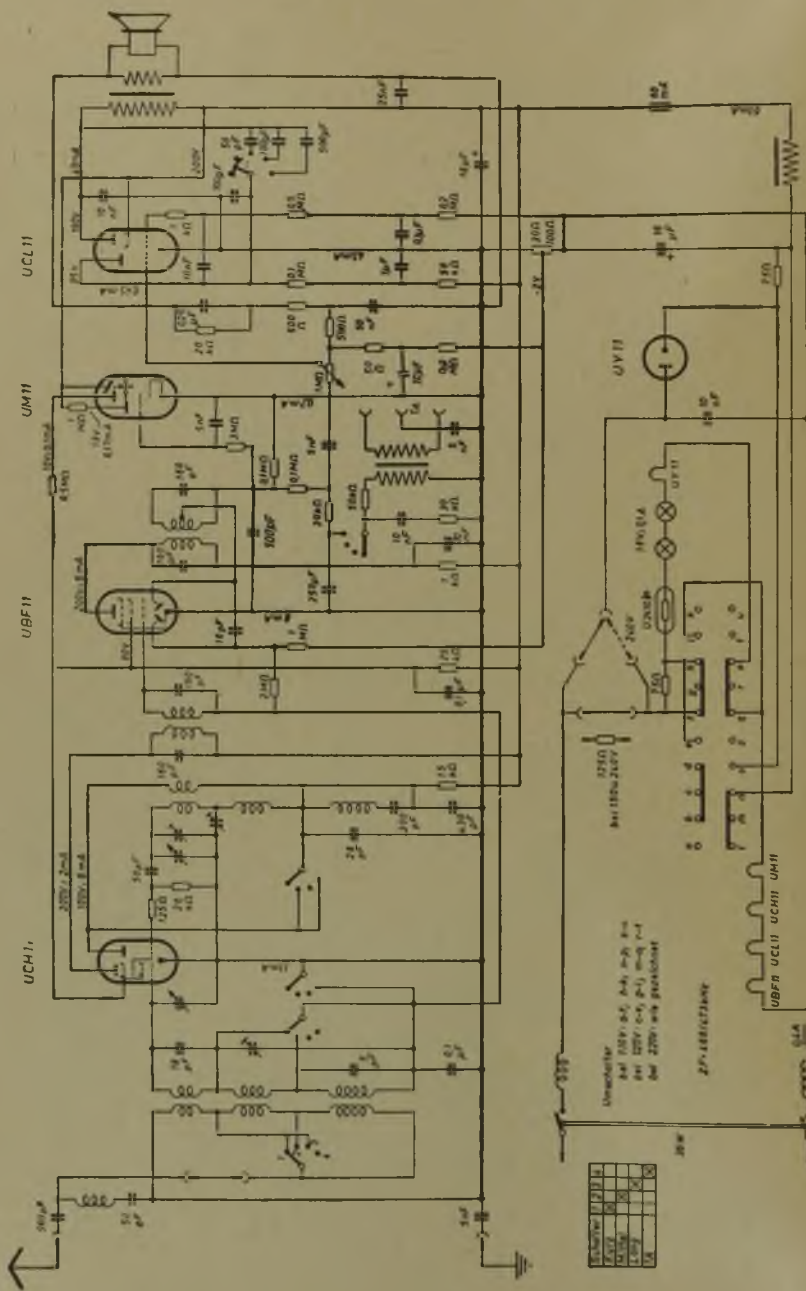

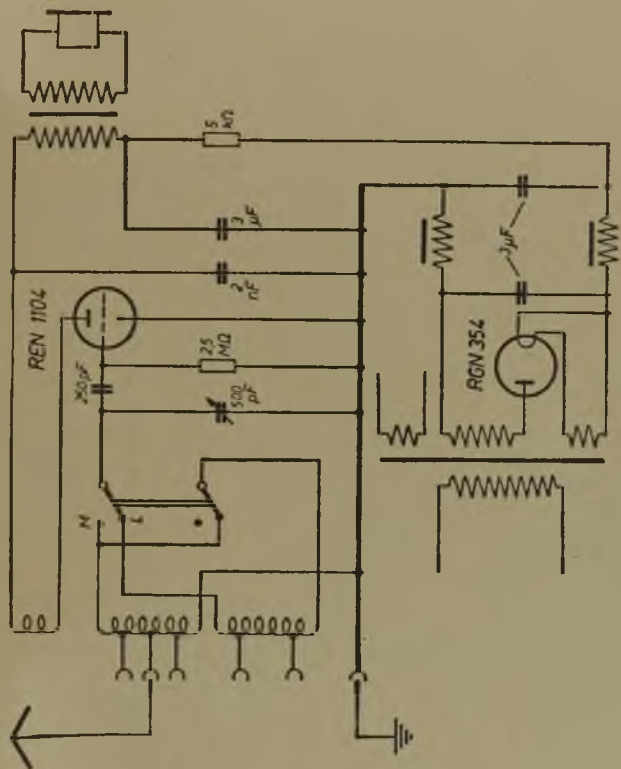

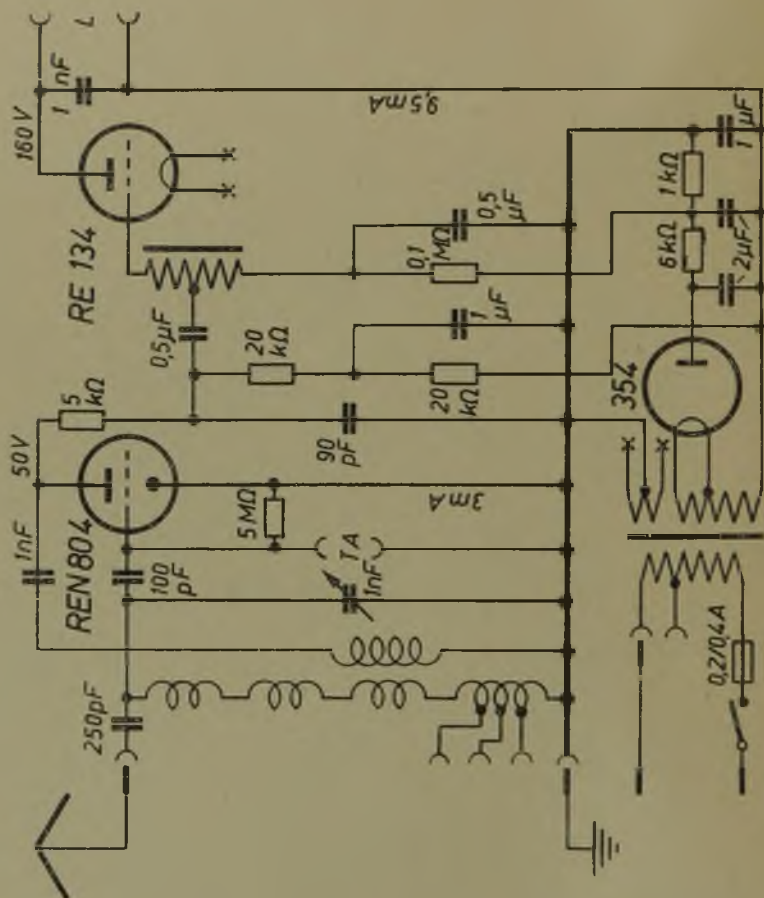

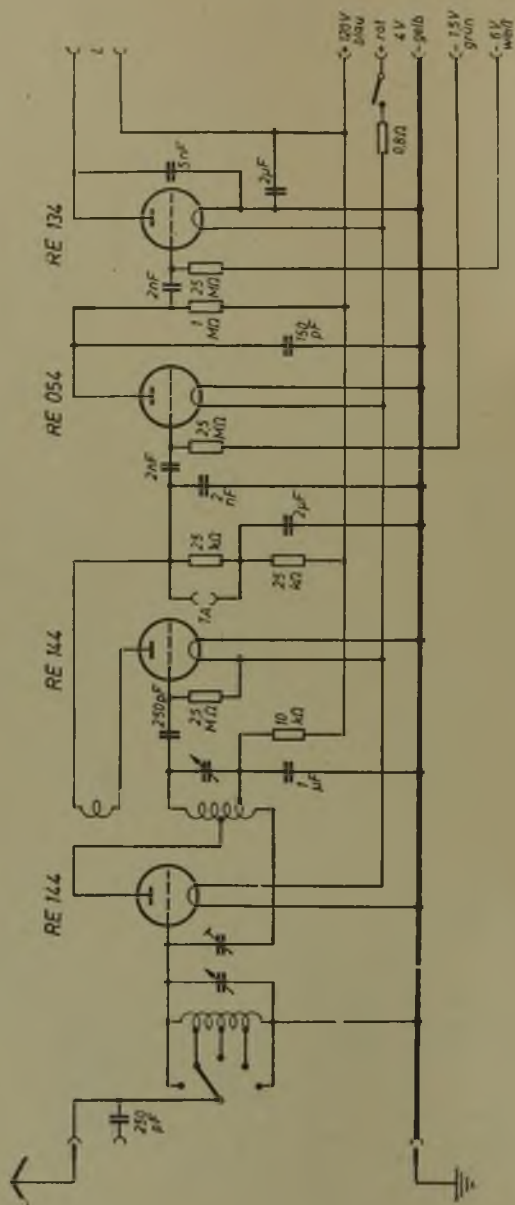

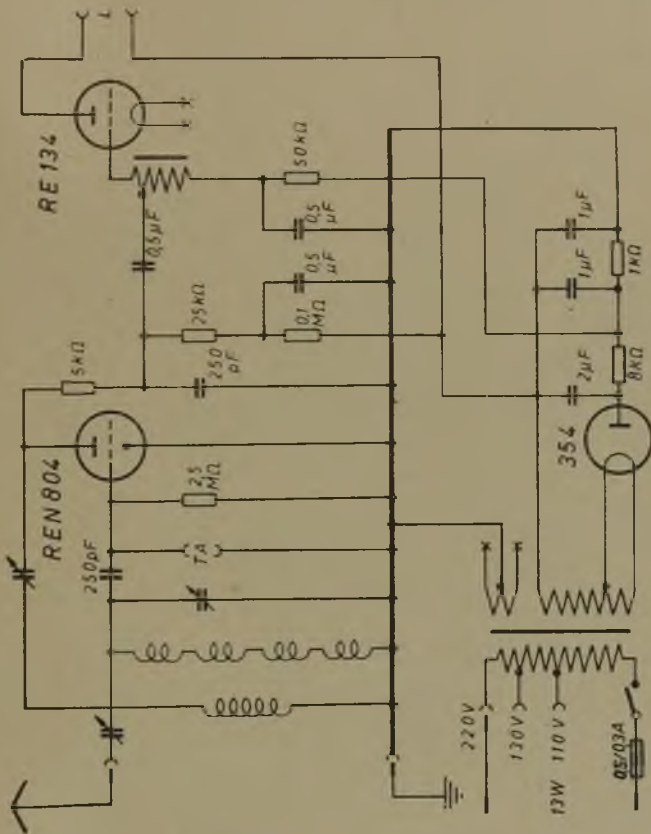

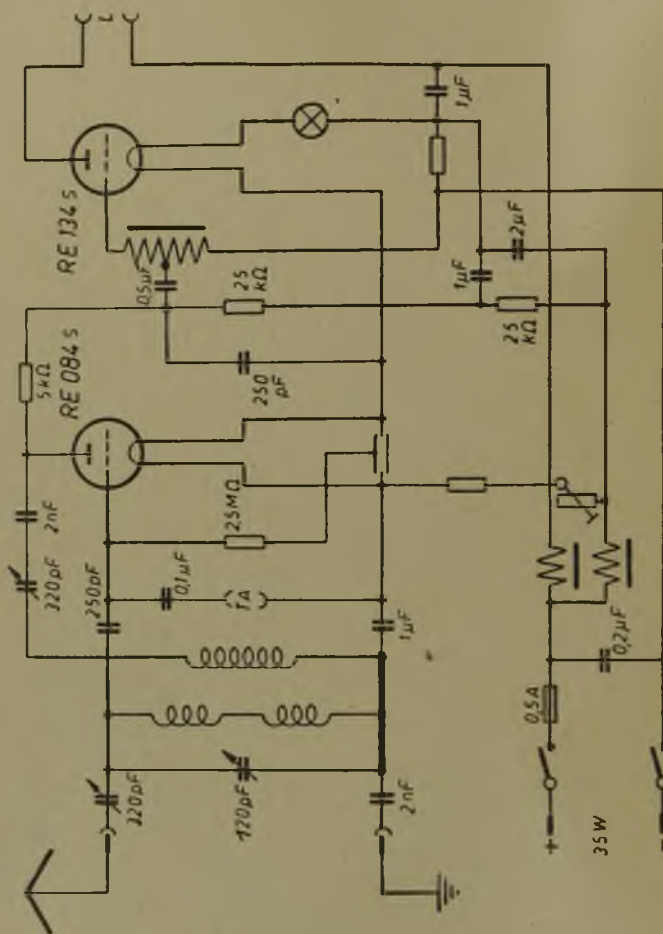

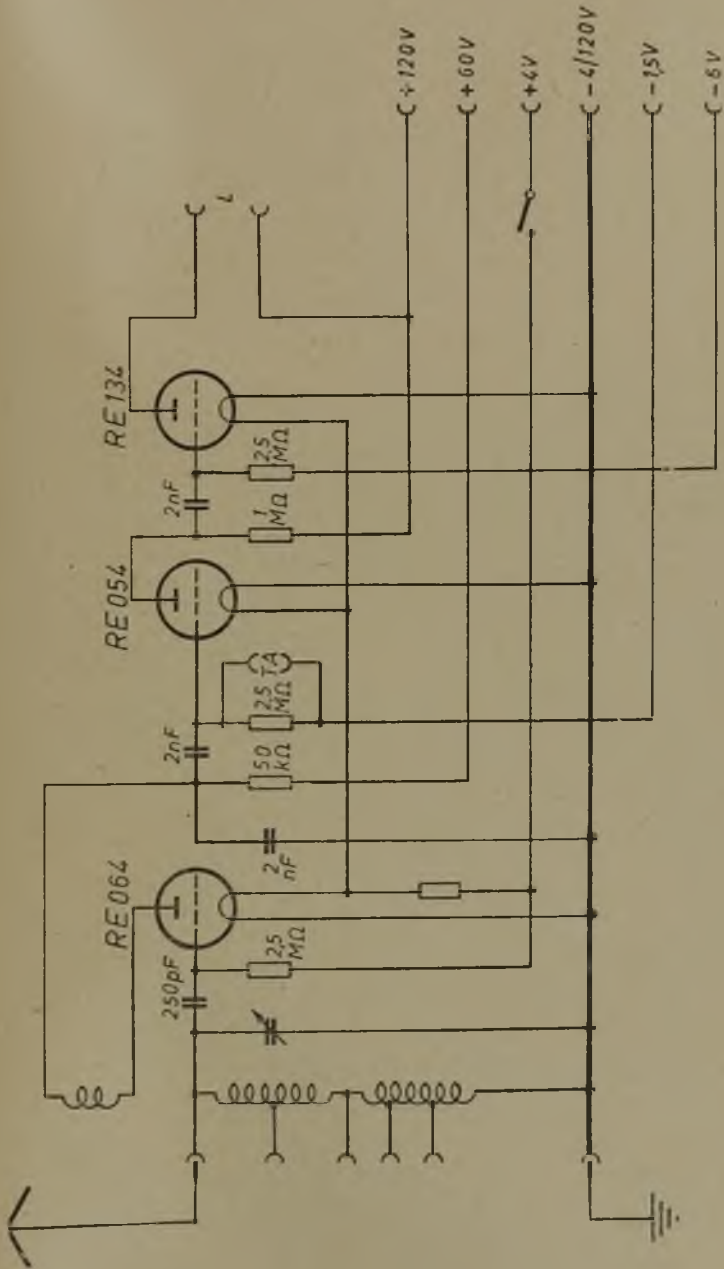

Siemens 20 GW

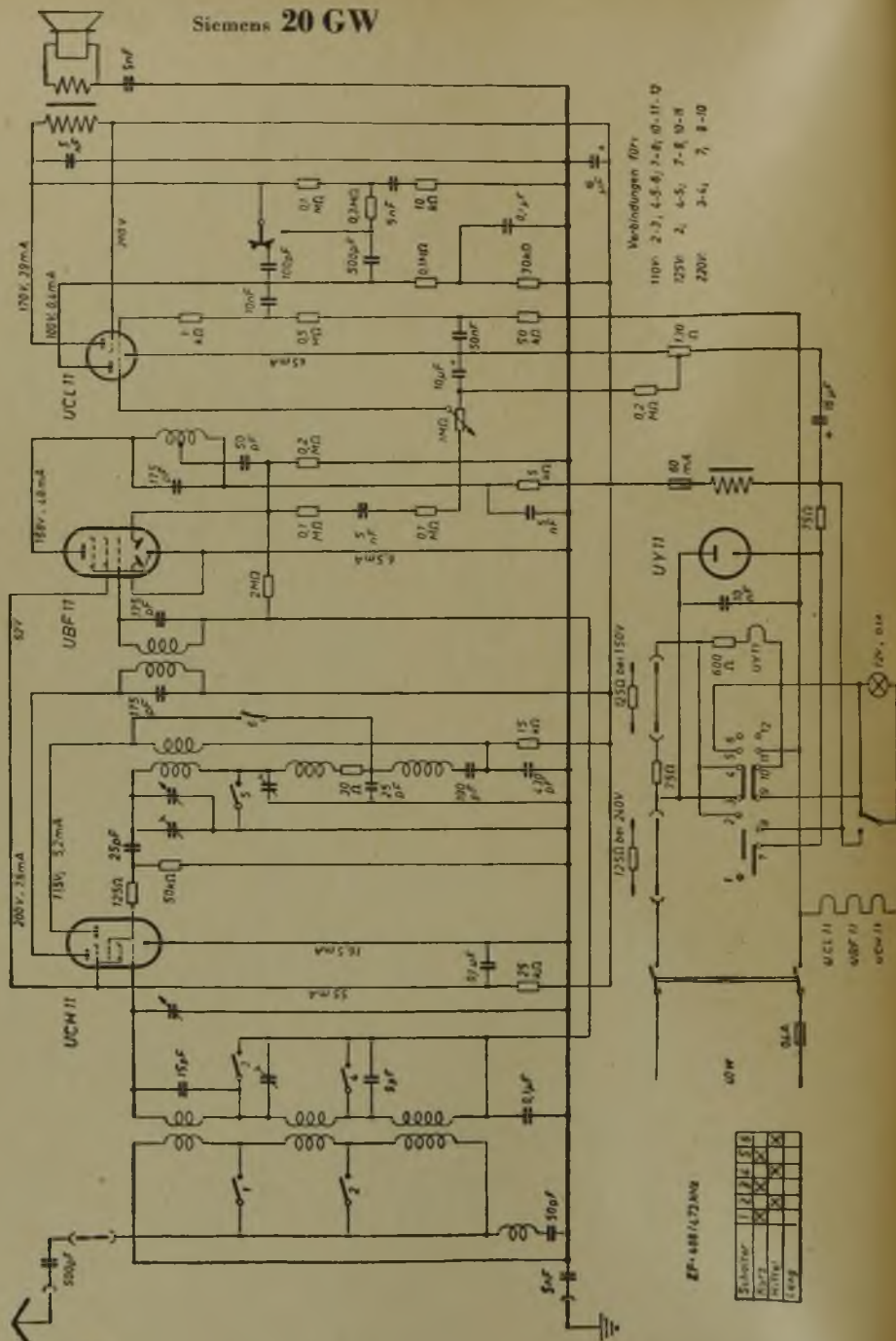

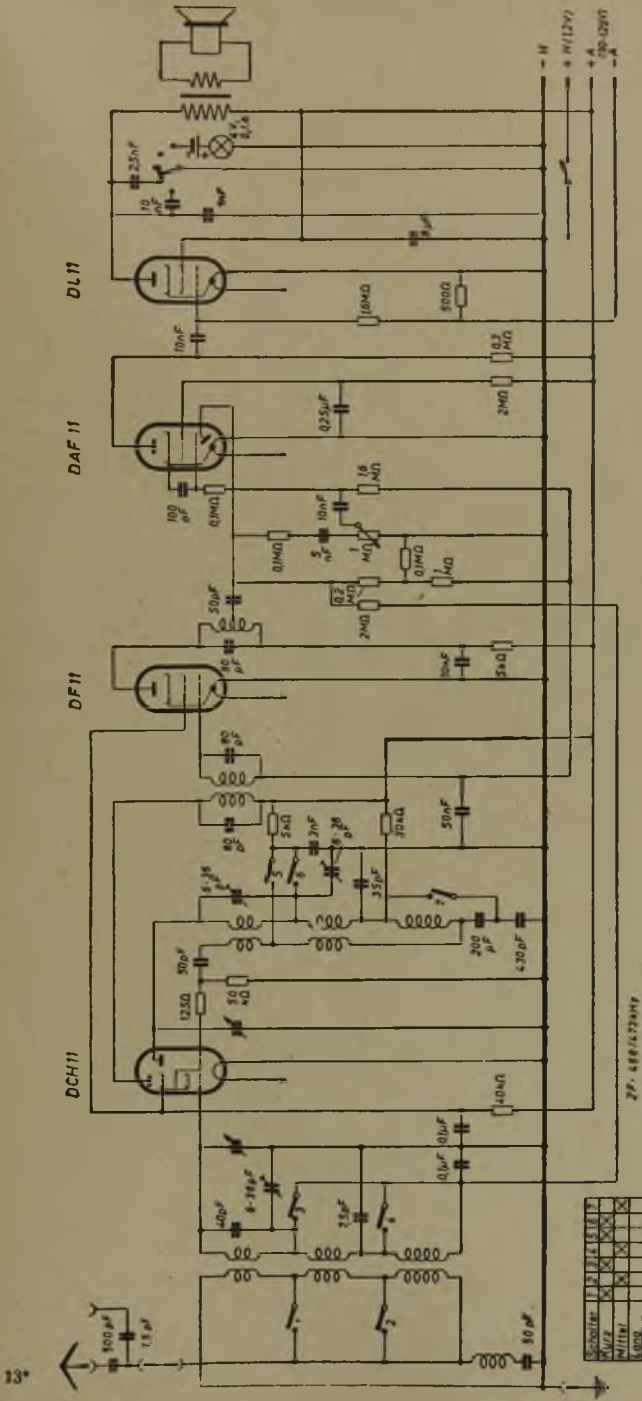

5000	5000	5000	5000	5000	5000
1000	1000	1000	1000	1000	1000
1000	1000	1000	1000	1000	1000
1000	1000	1000	1000	1000	1000
1000	1000	1000	1000	1000	1000
1000	1000	1000	1000	1000	1000

Siemens 15 W
(linke Seite des Schaltbildes)

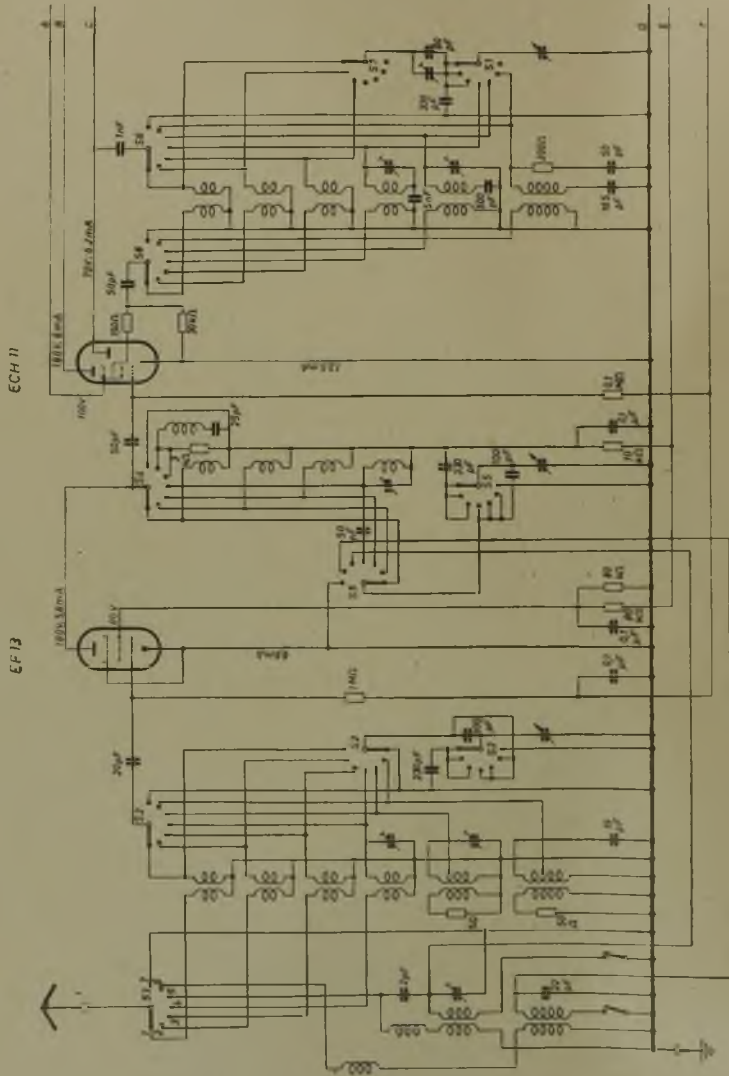

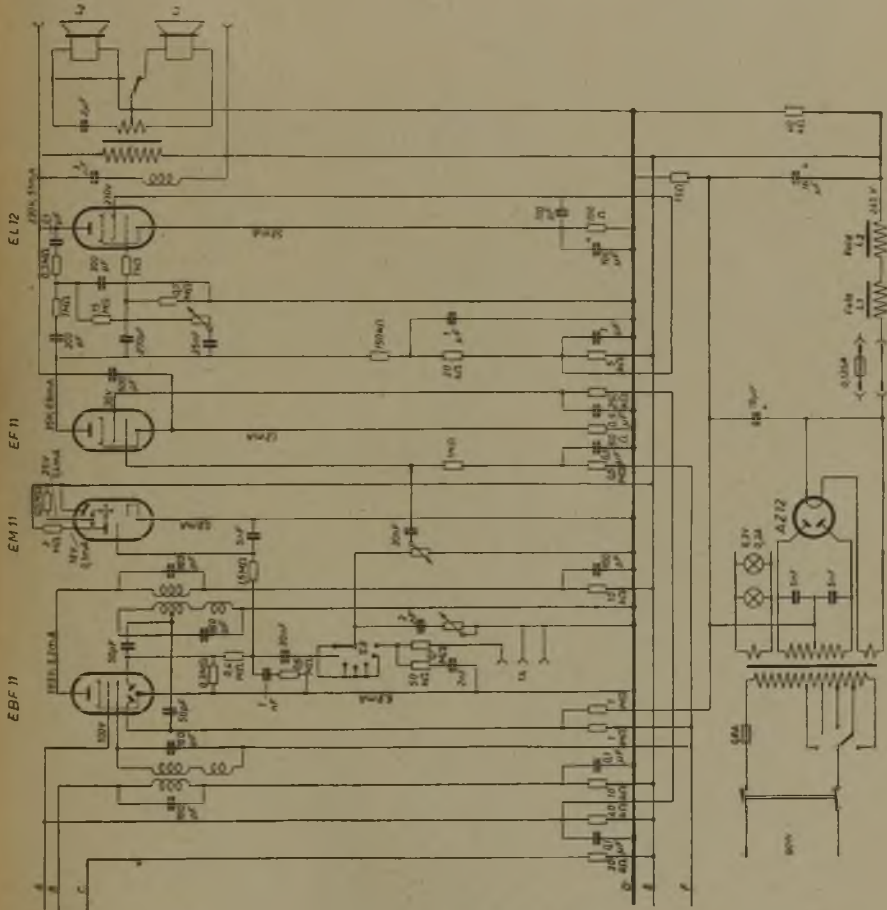

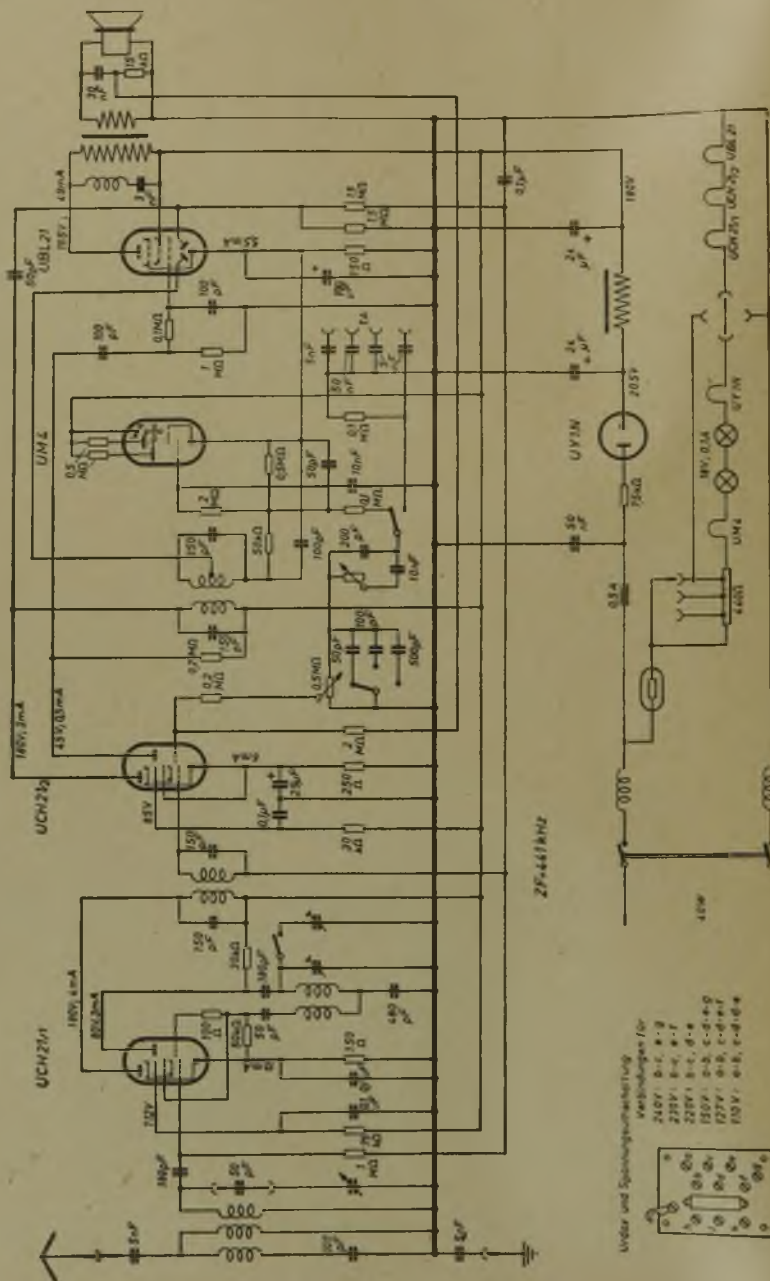

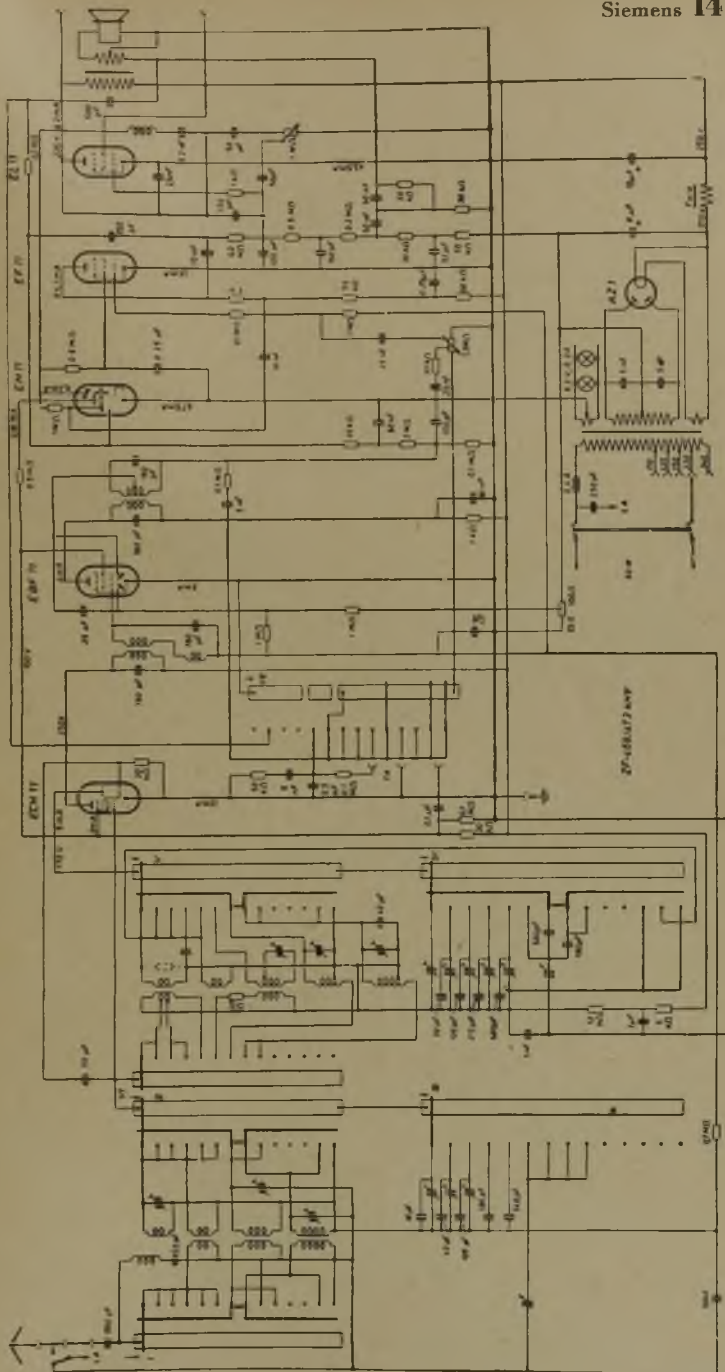

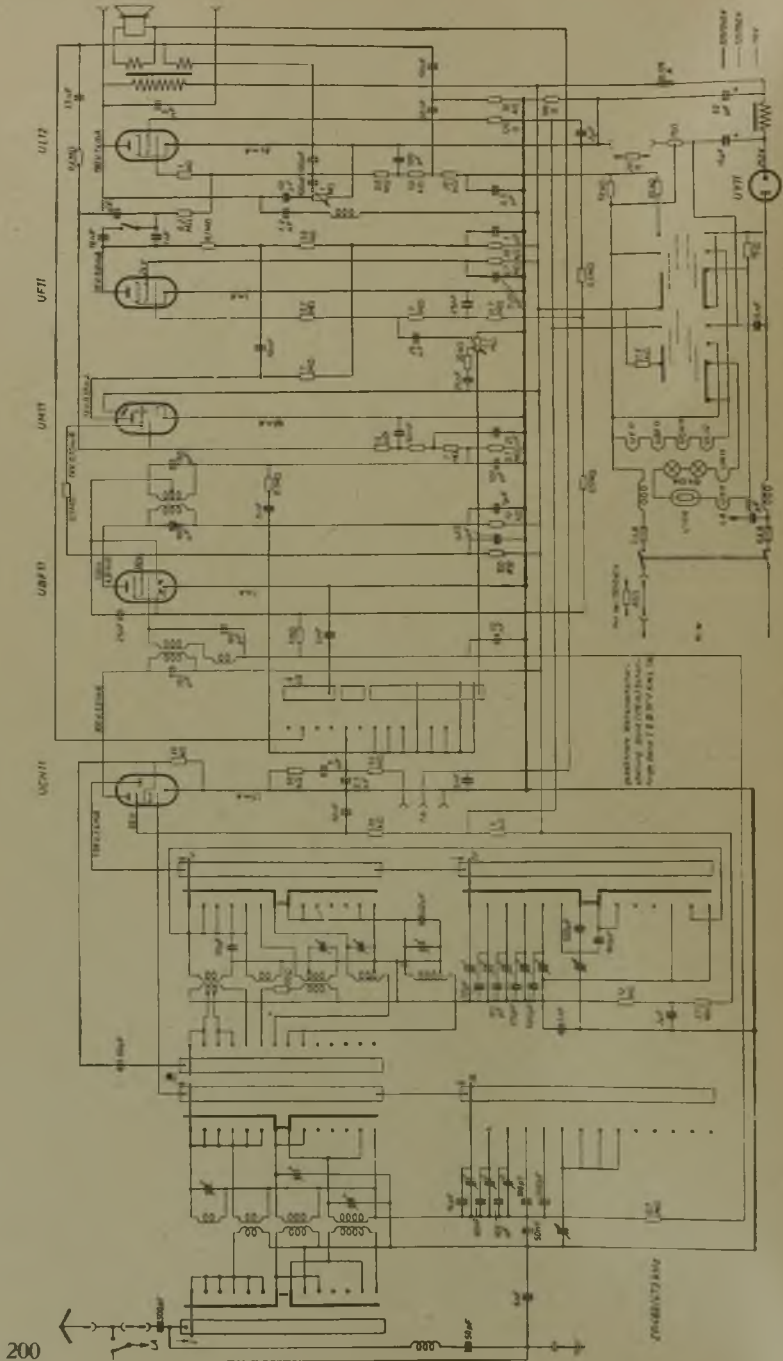

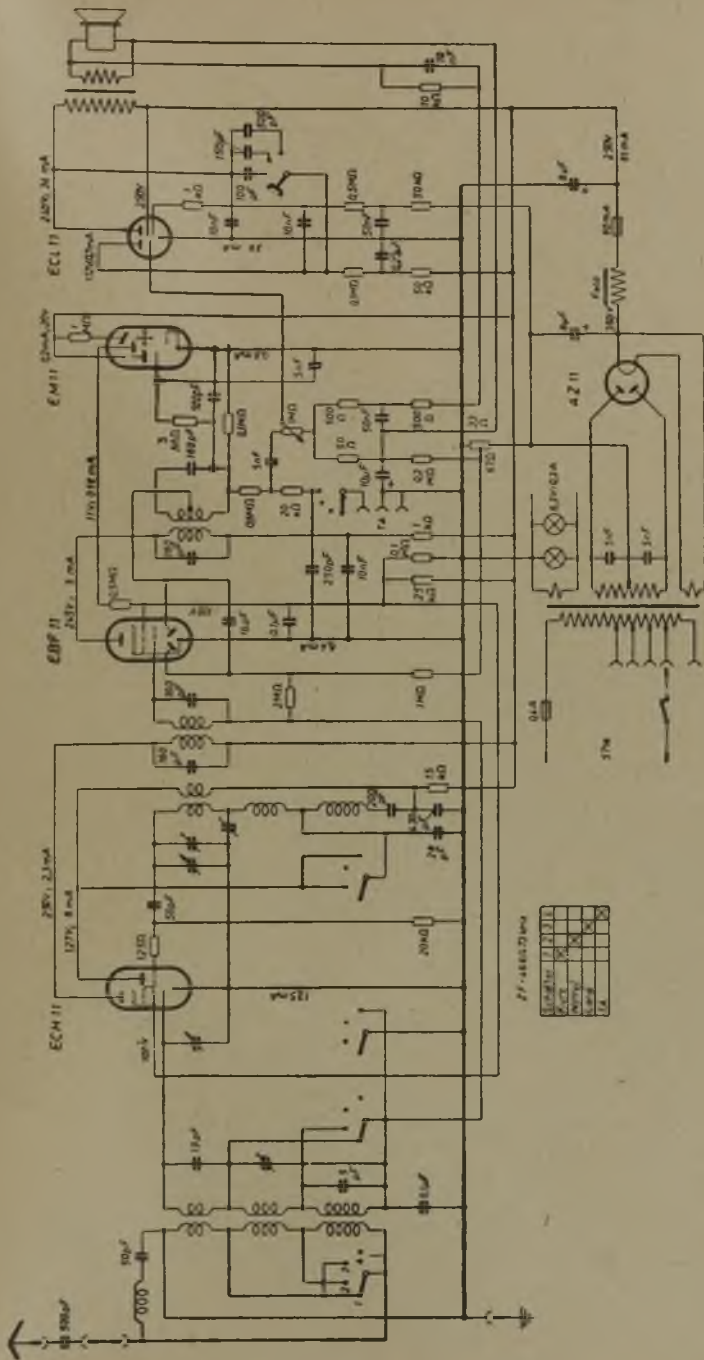

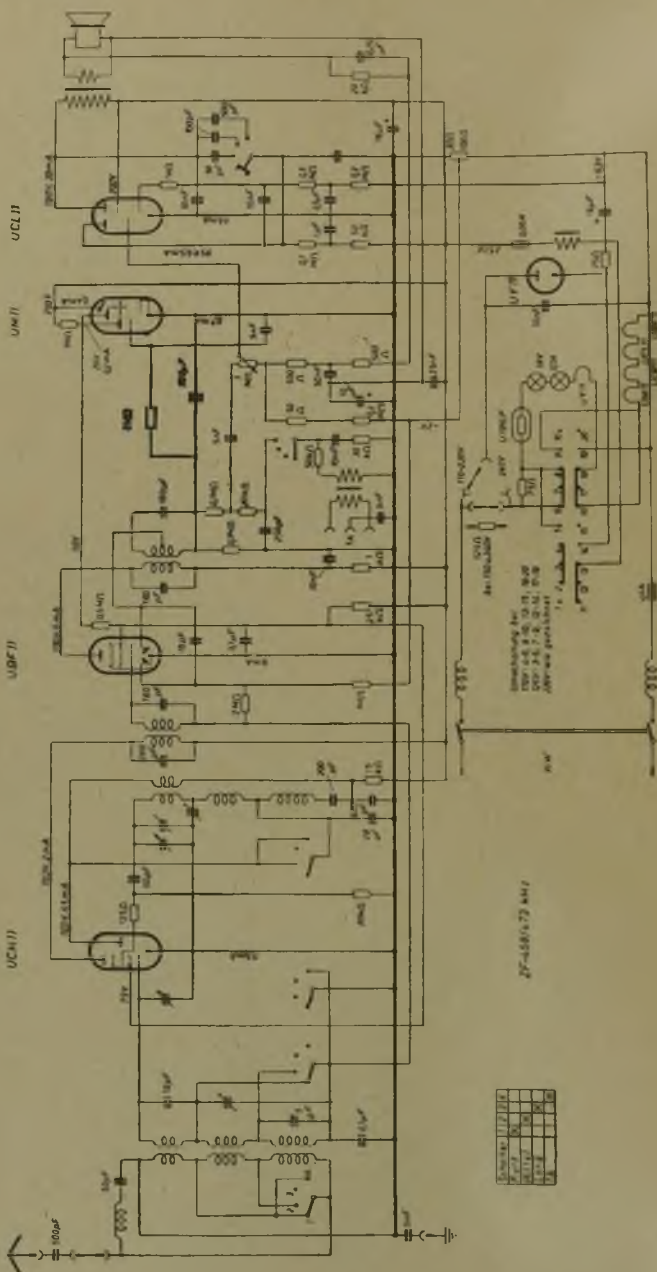

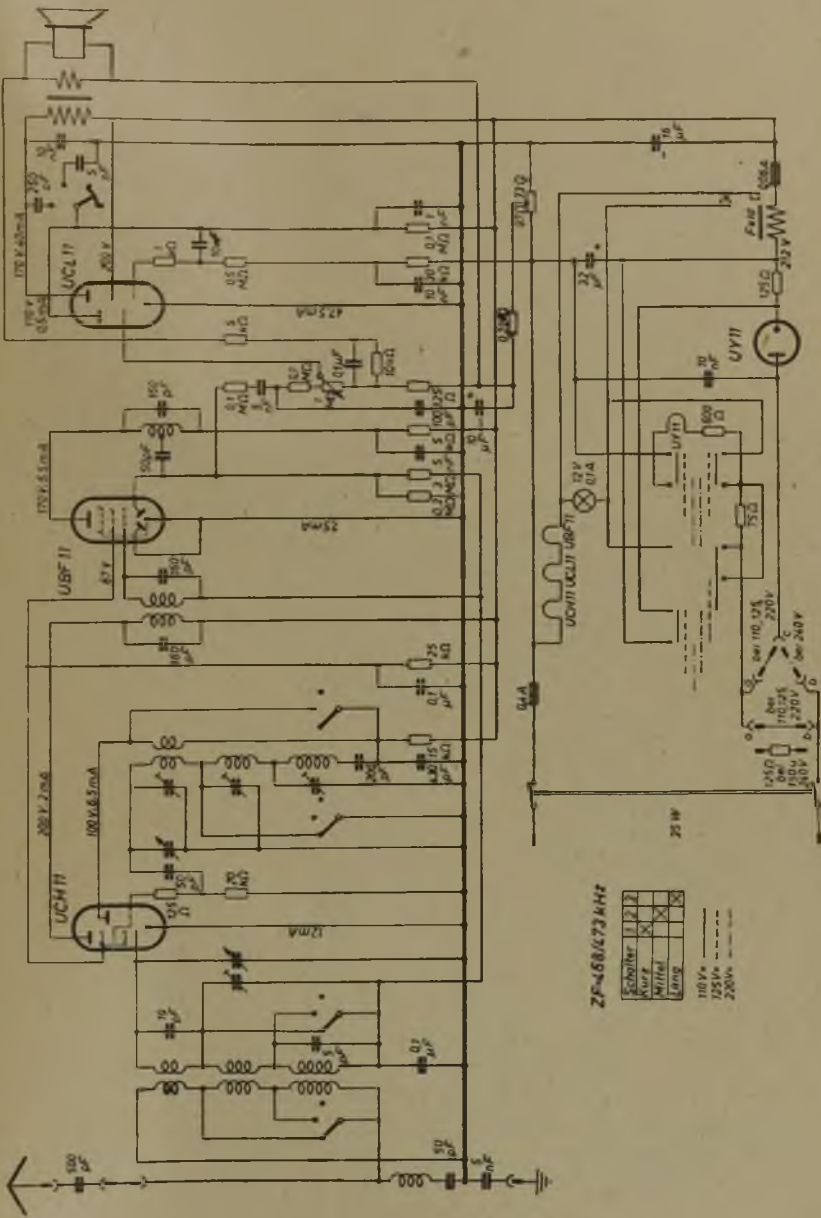

ZF-458/473 MHz

Schaltung	1	2	3
Kopf	X	X	X
Mittel			X
Lang			X

- 10V - - - - -
- 25V - - - - -
- 200V - - - - -

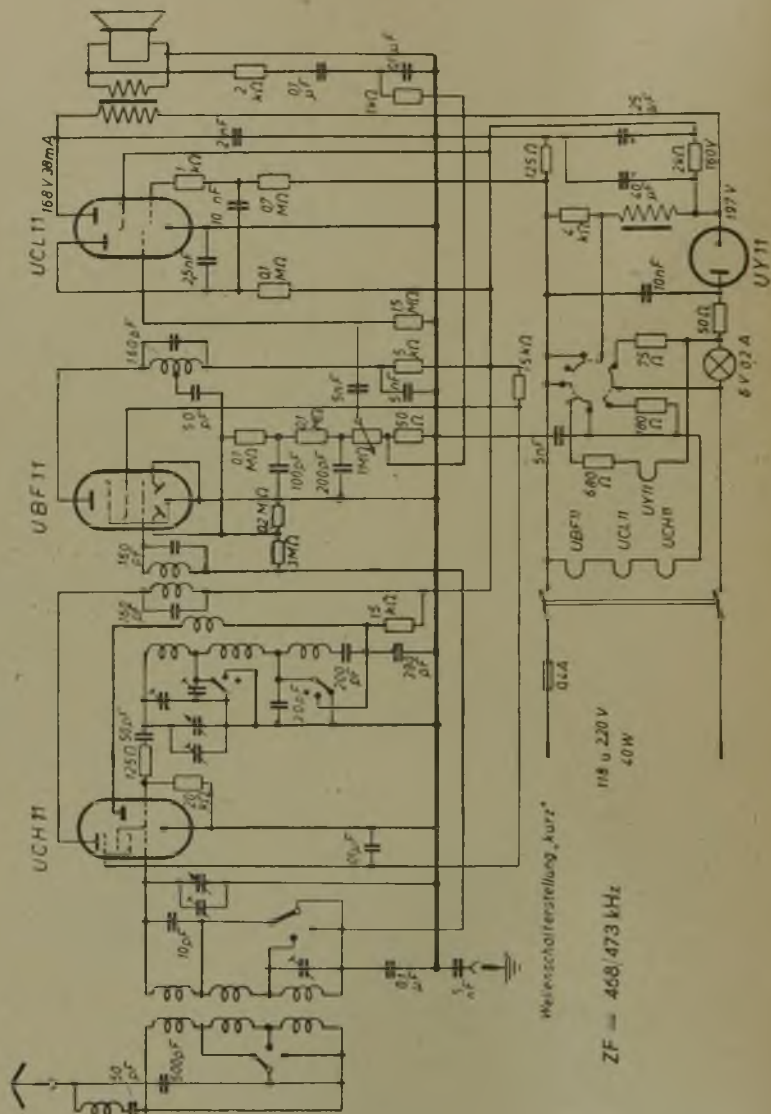

Weisschaltstellung „kurz“

ZF = 468/473 kHz

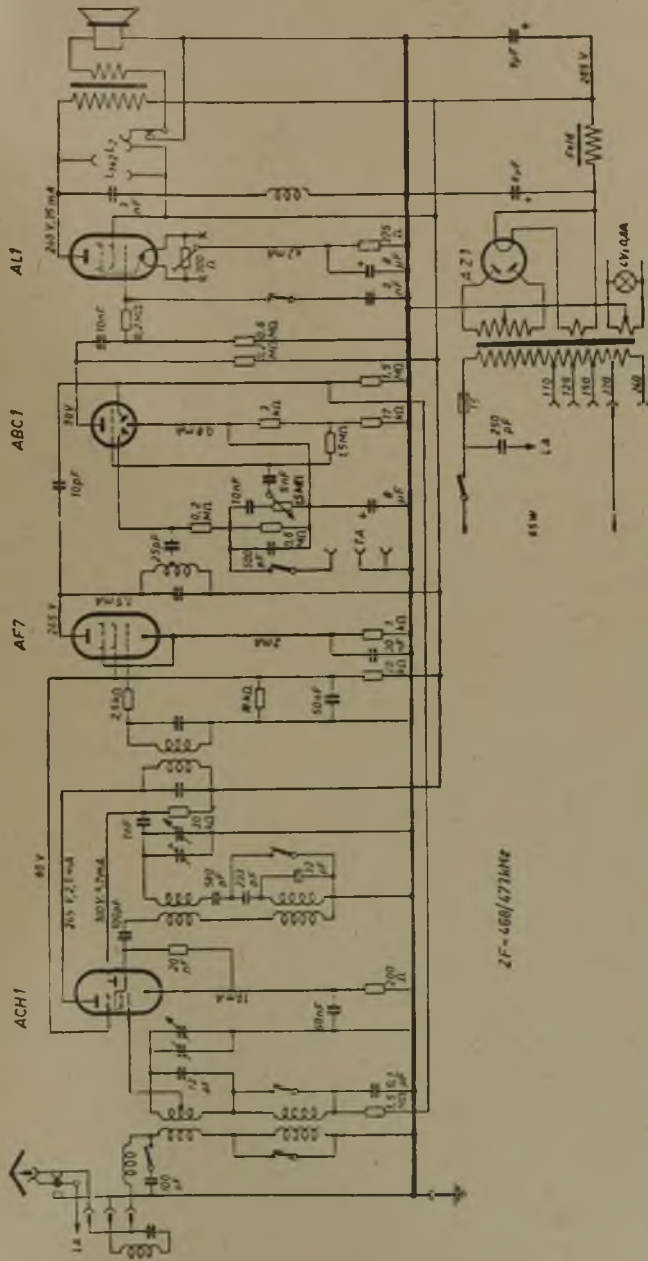

SIEMENS-WECHSELRICHTER

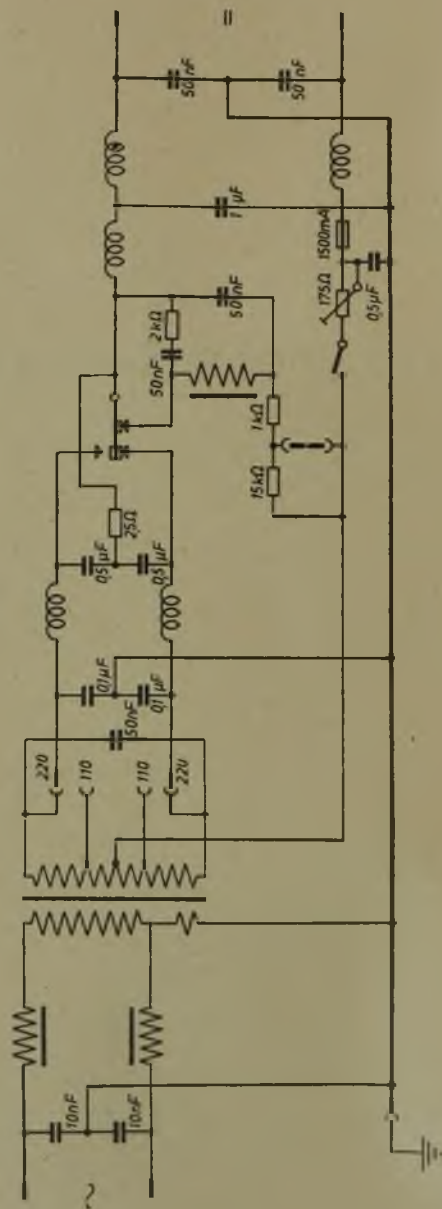

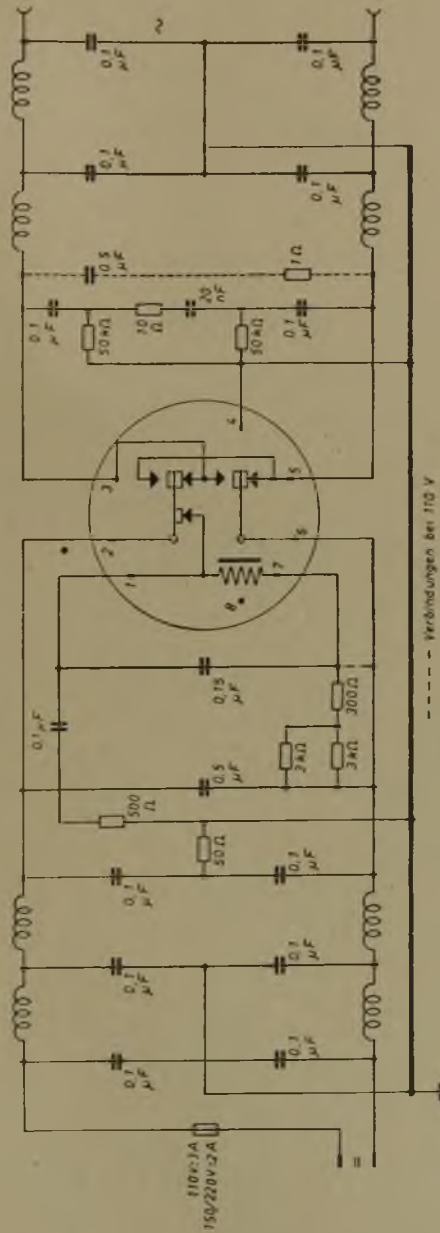

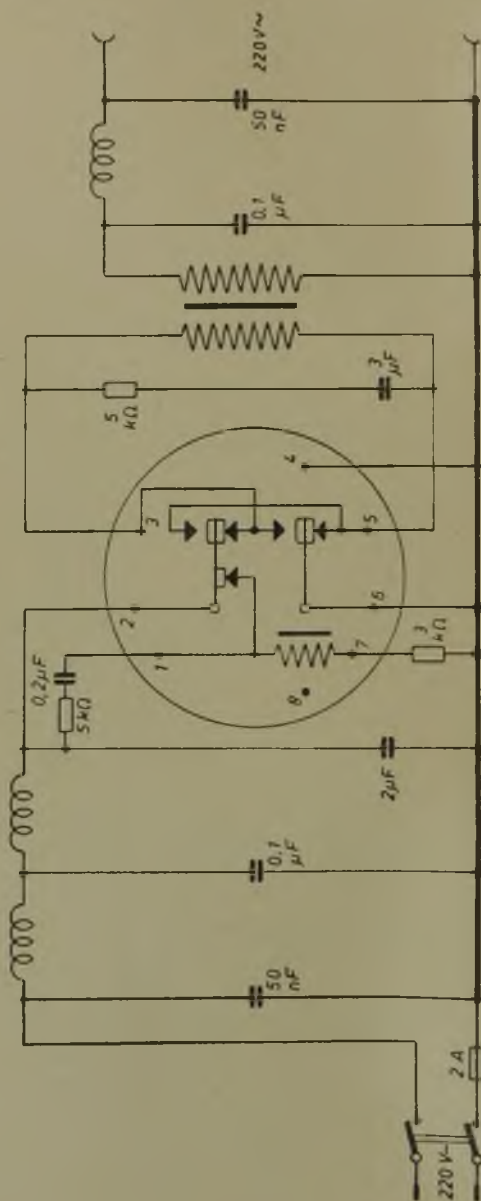

SIEMENS-VERSTÄRKER

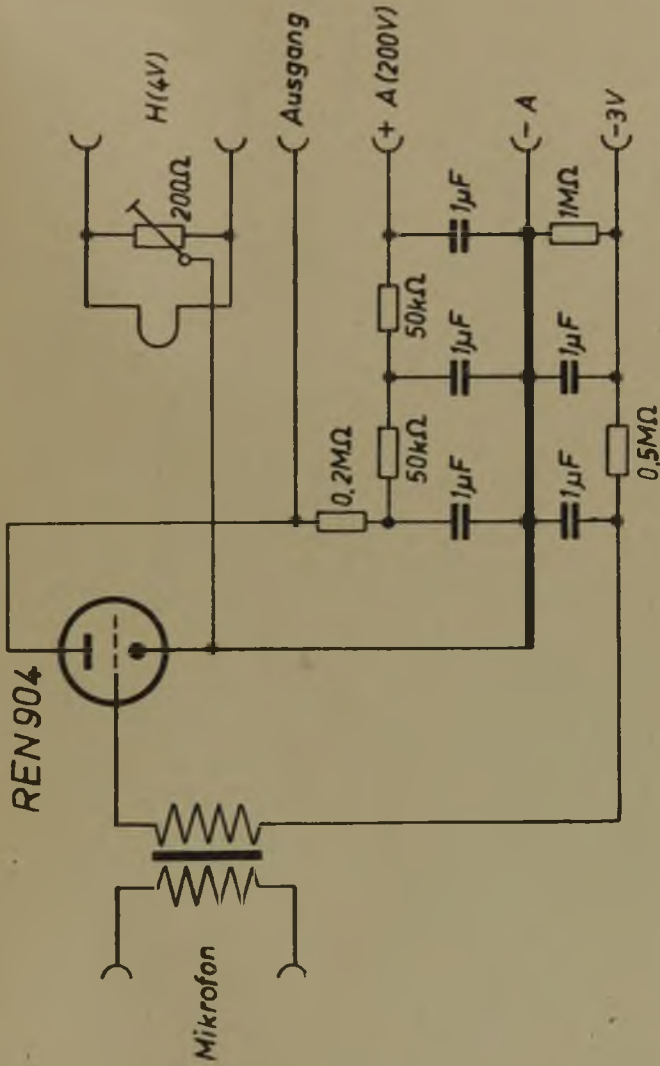

Siemens **SMV 1a** (Mikrofonvorverstärker)

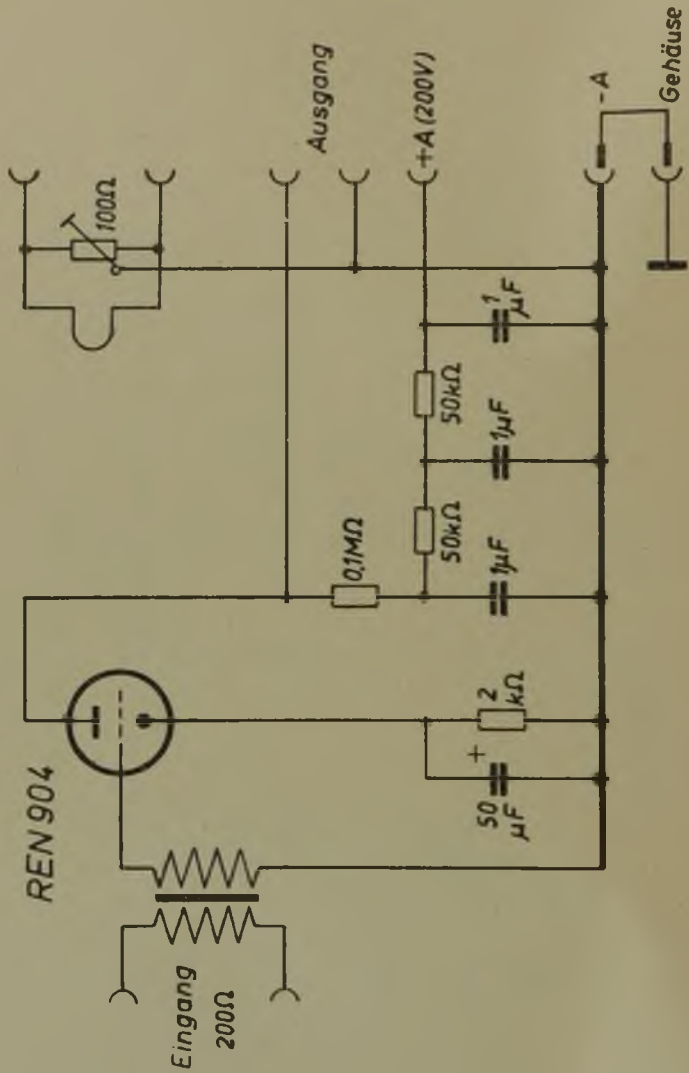

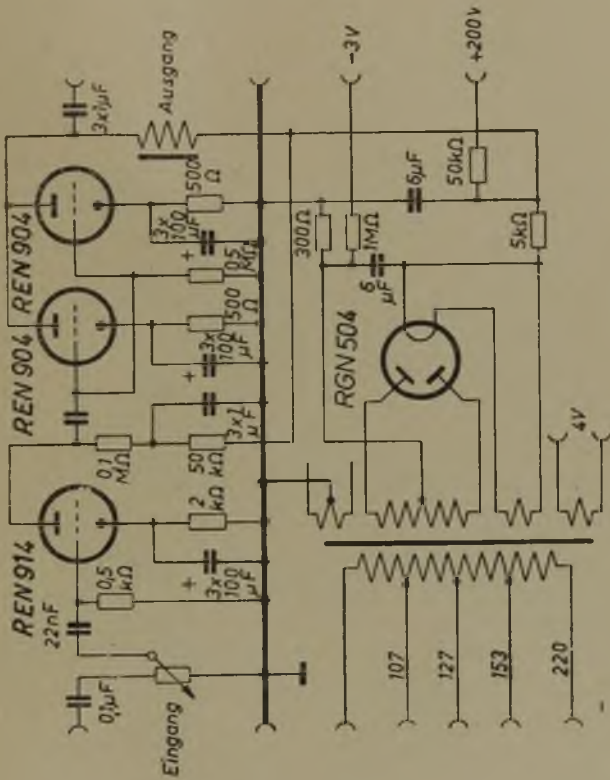

Siemens **SV 1/1** (Steuerverstärker)

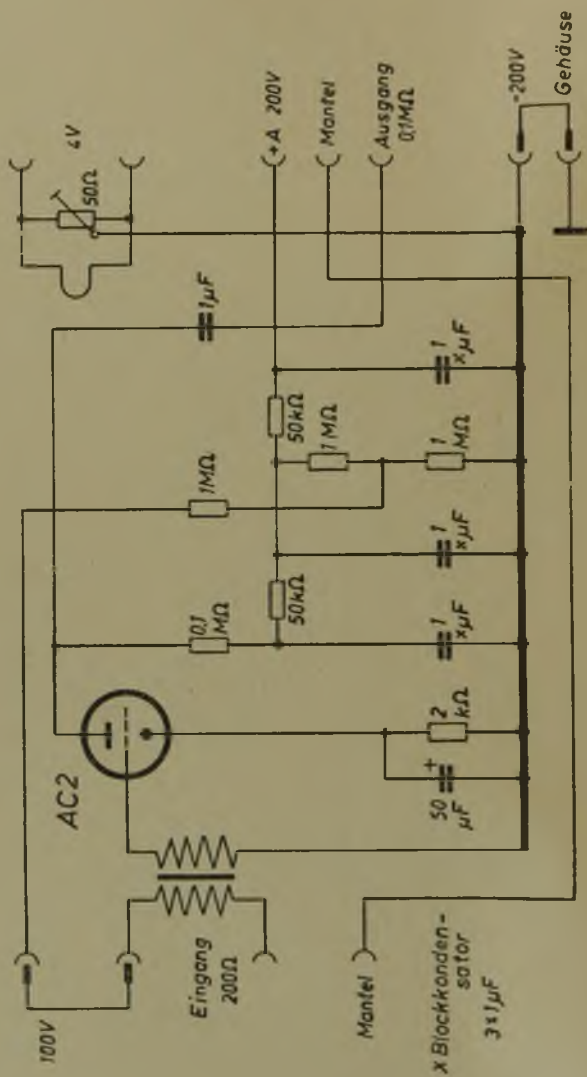

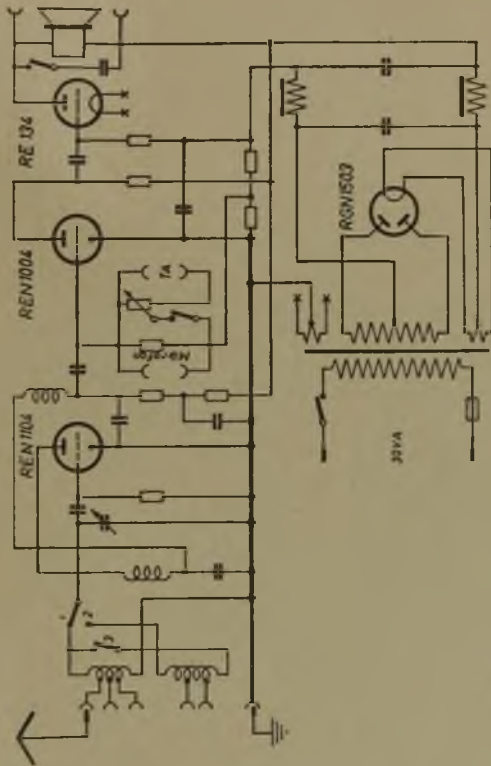

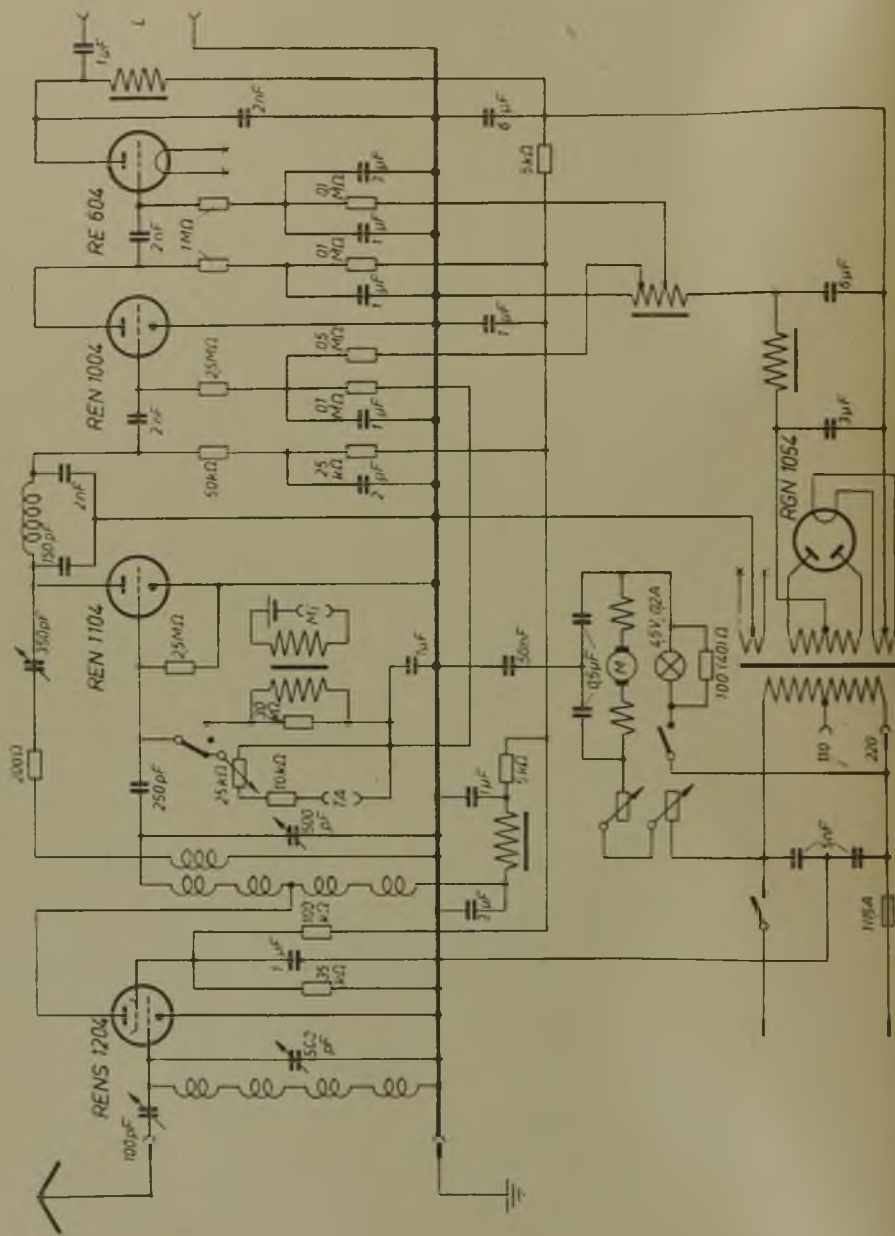

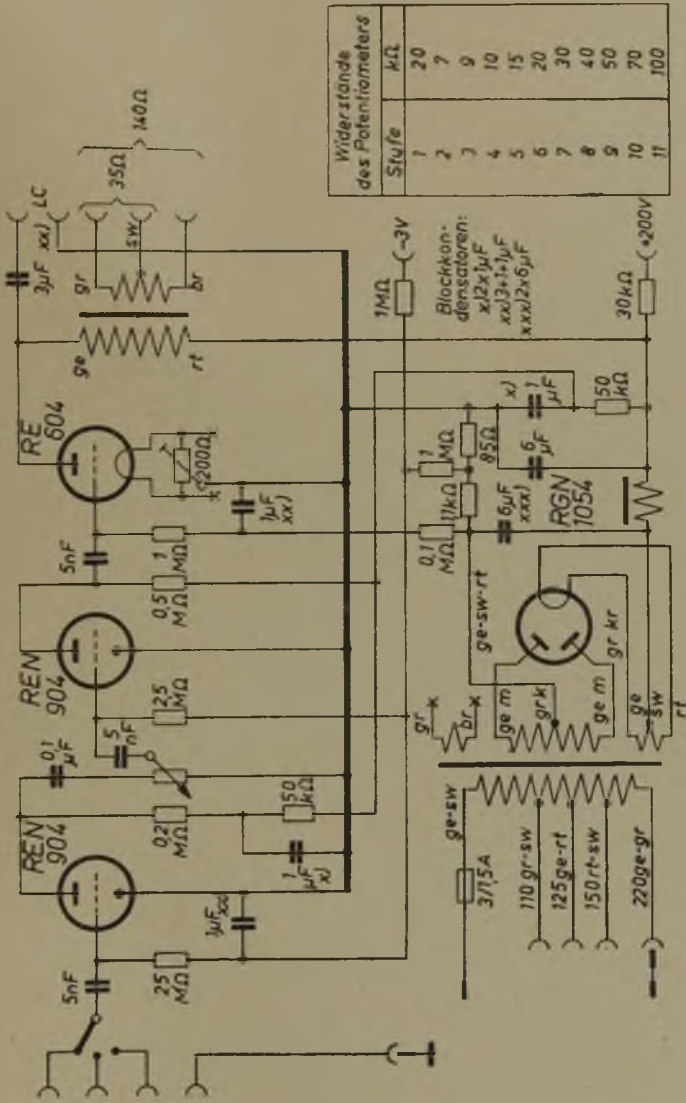

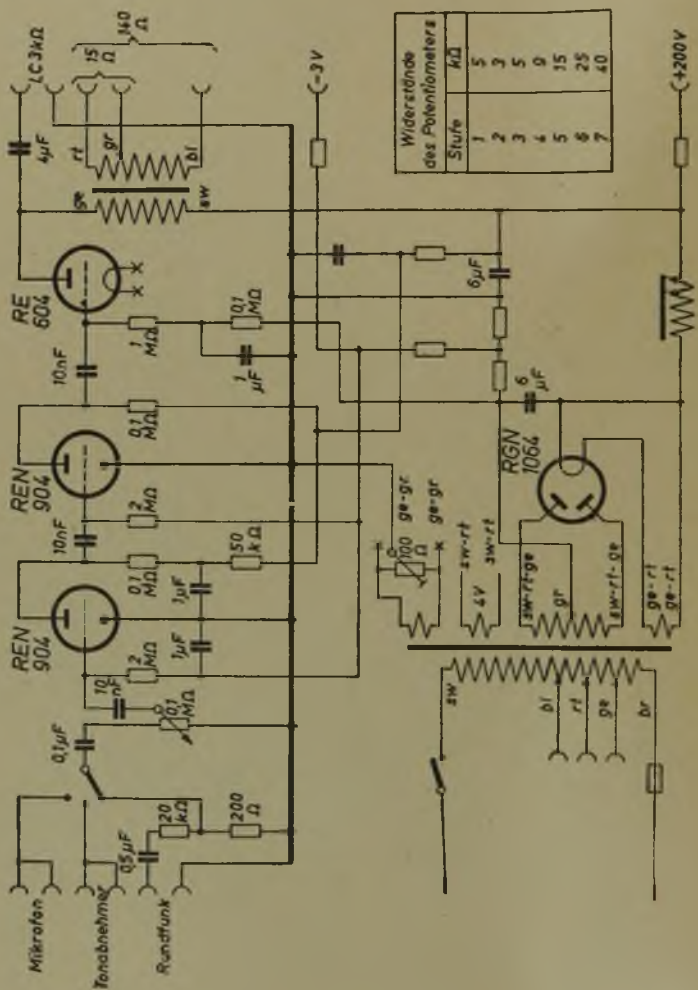

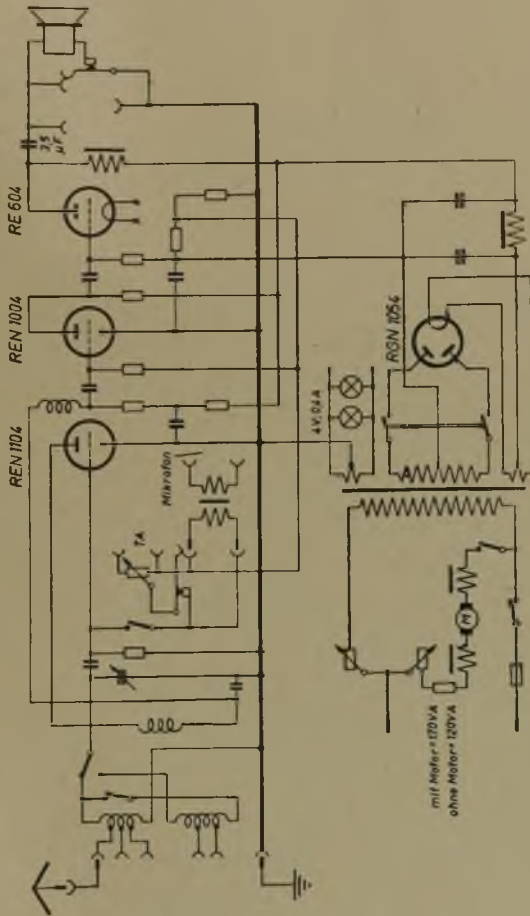

Siemens E verst 2 b/1 und 2 b/2 (25-Watt-Verstärker)

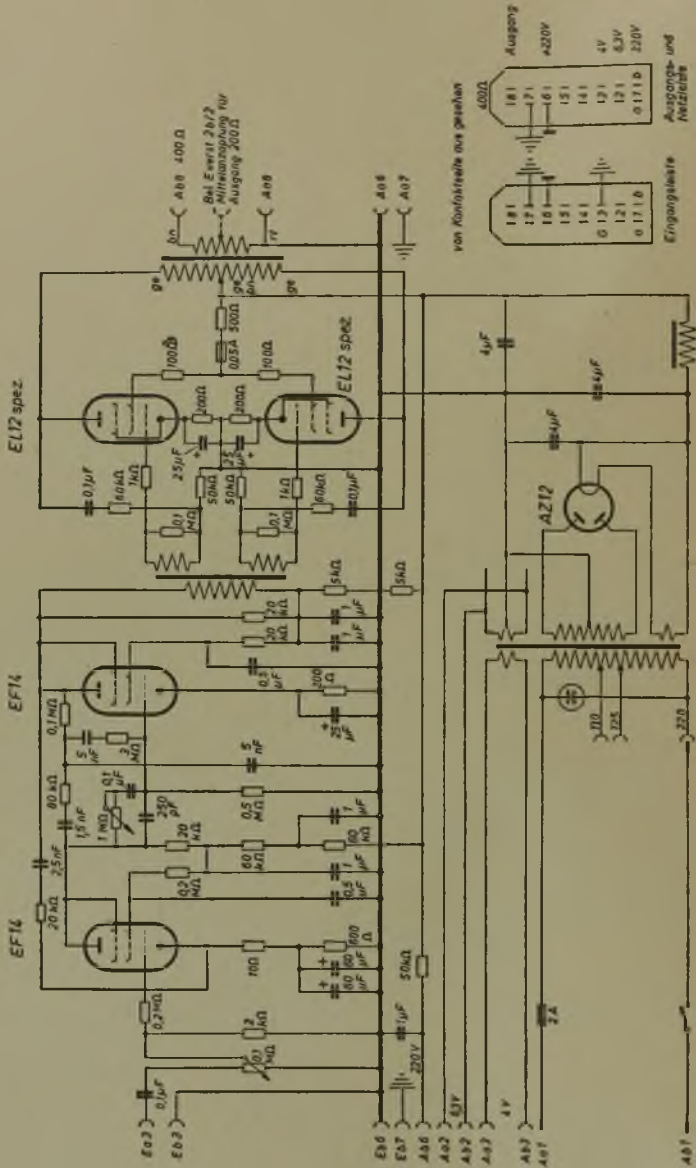

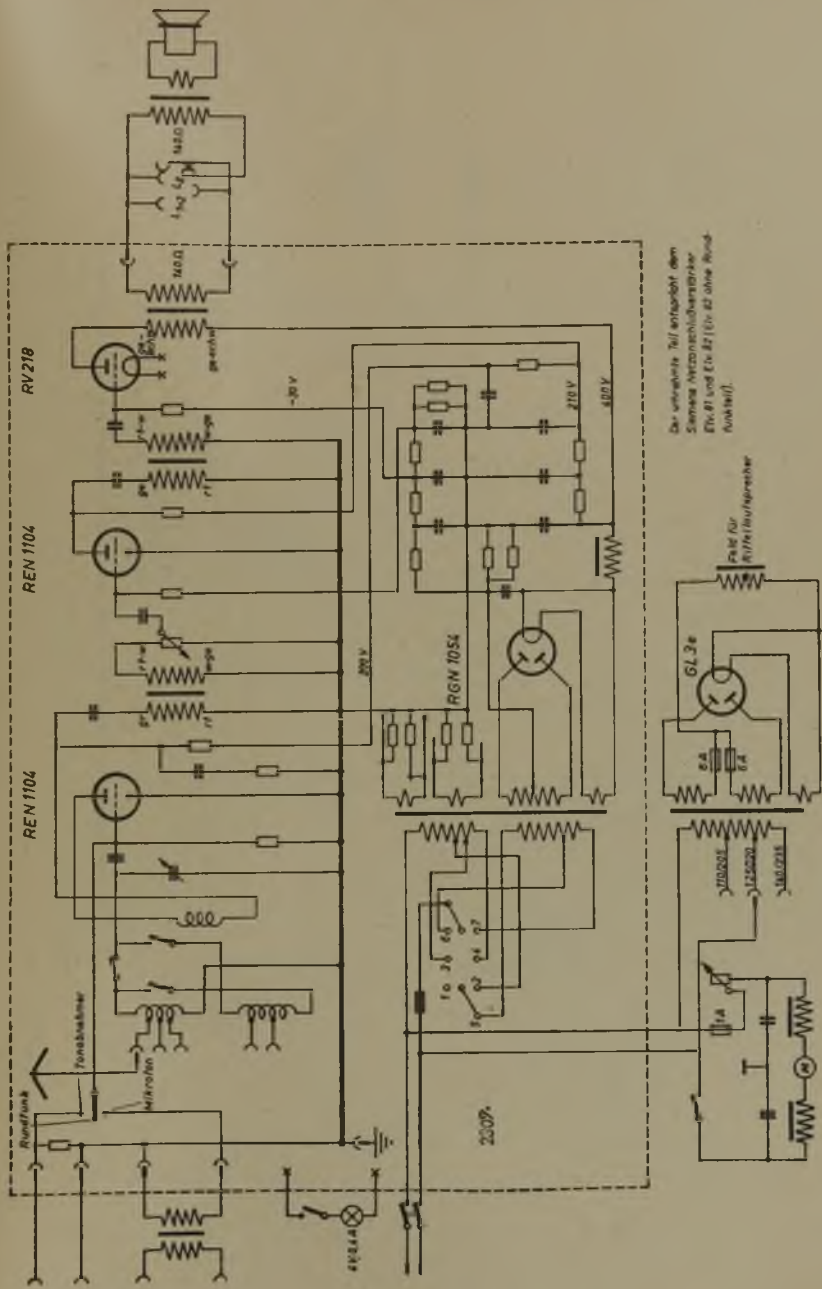

Der erwähnte Teil entspricht dem
Siemens Mikroenschaltwerk
Typ. 81 und Typ. 82 (für 82 ohne Rund-
funkteil).

Siemens **E verst 4a/1** (Mikrofonvorverstärker)

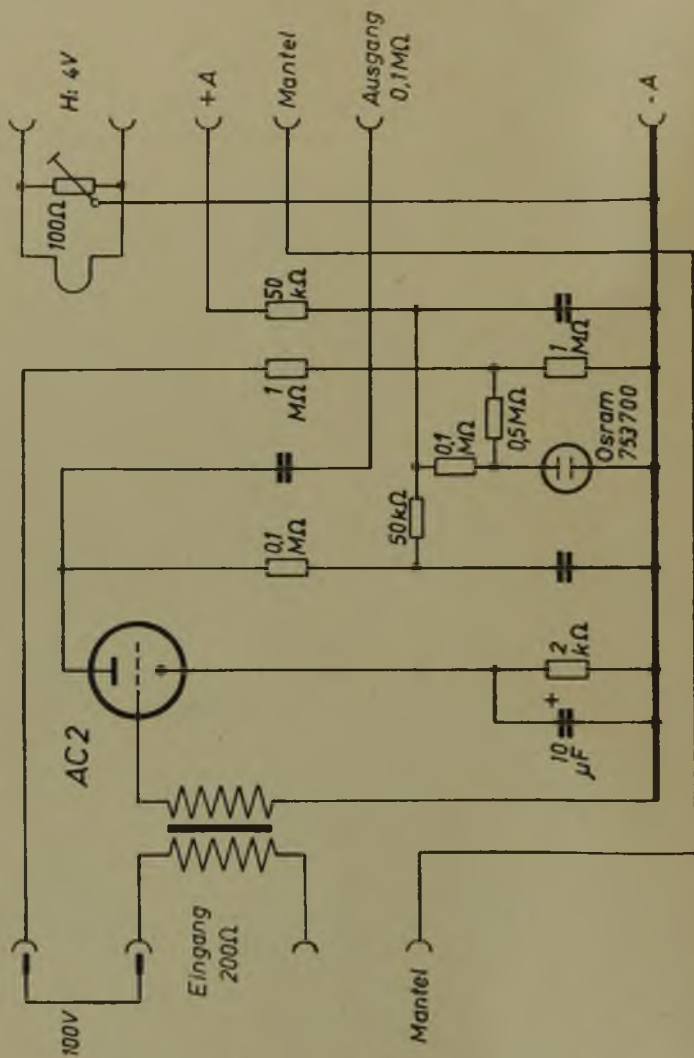

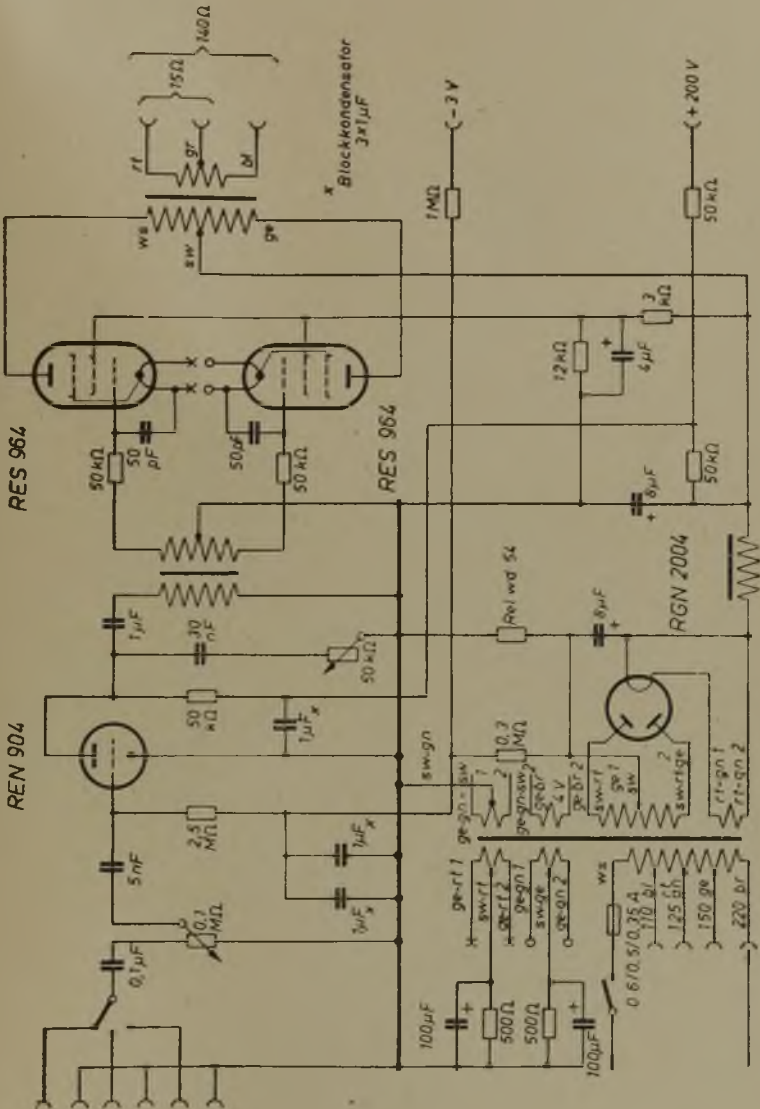

Siemens **SV 8a W** (7,5-Watt-Verstärker)

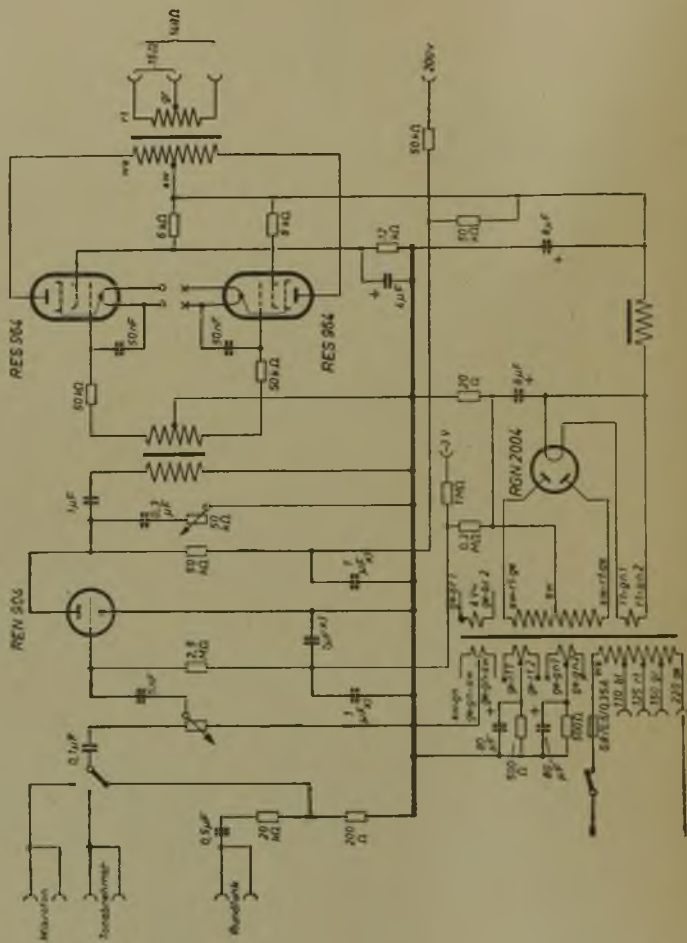

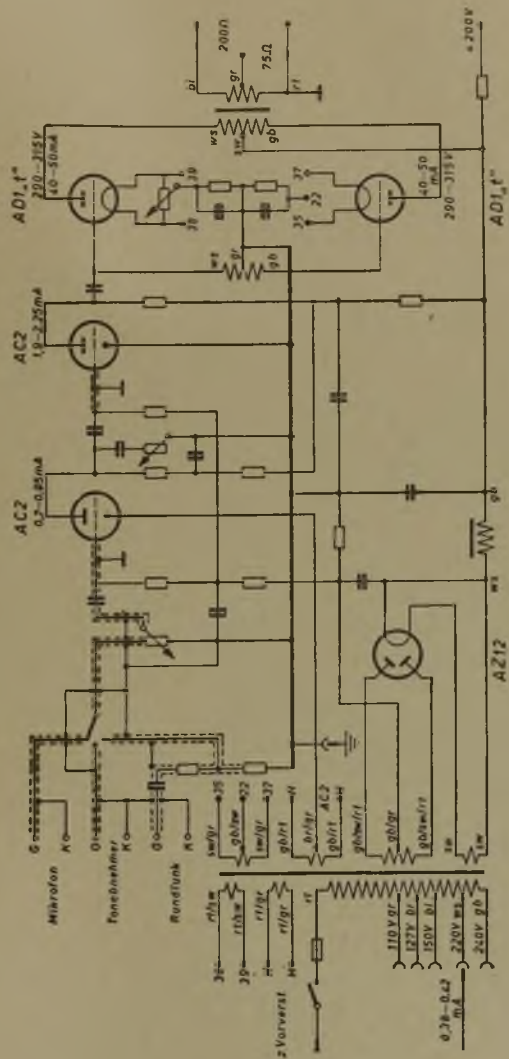

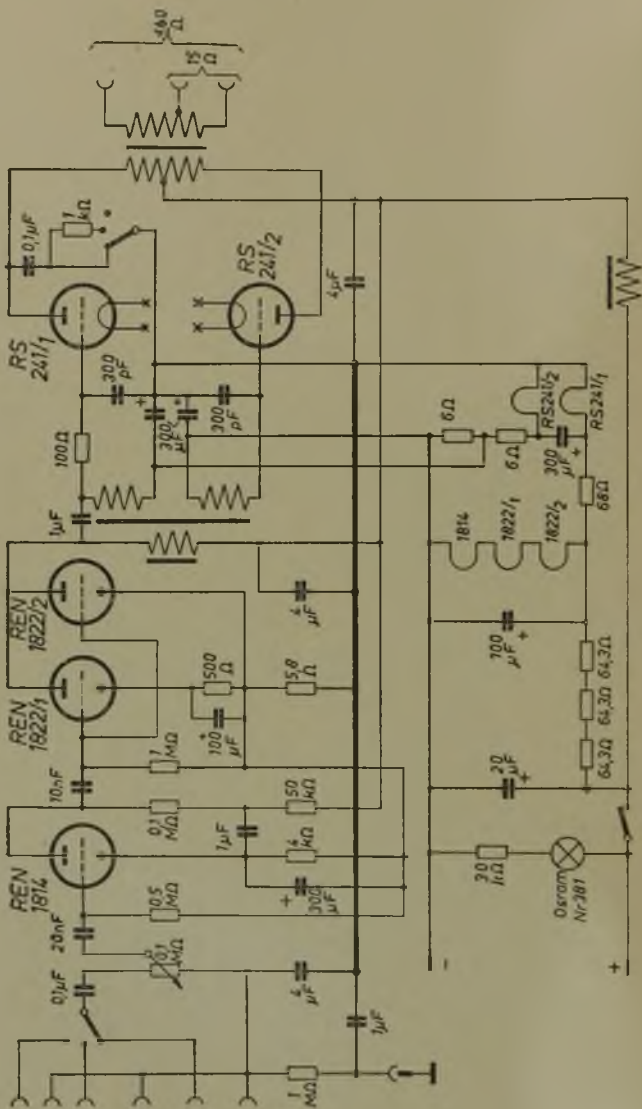

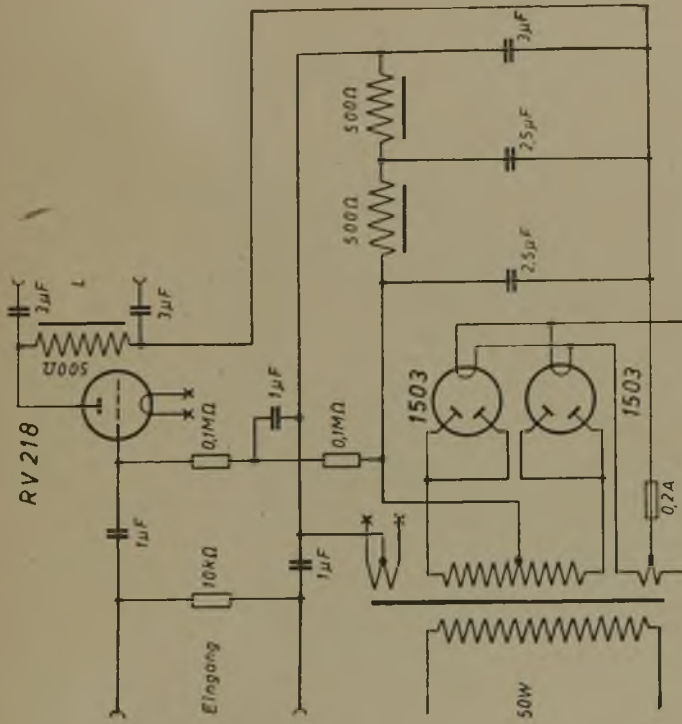

Siemens **Rfv 12 b** (Netzendstufe)

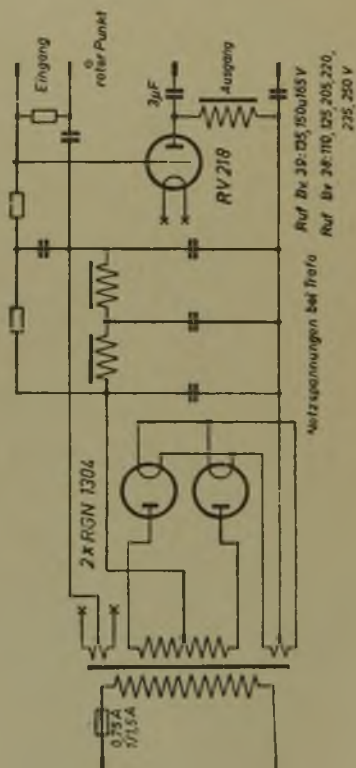

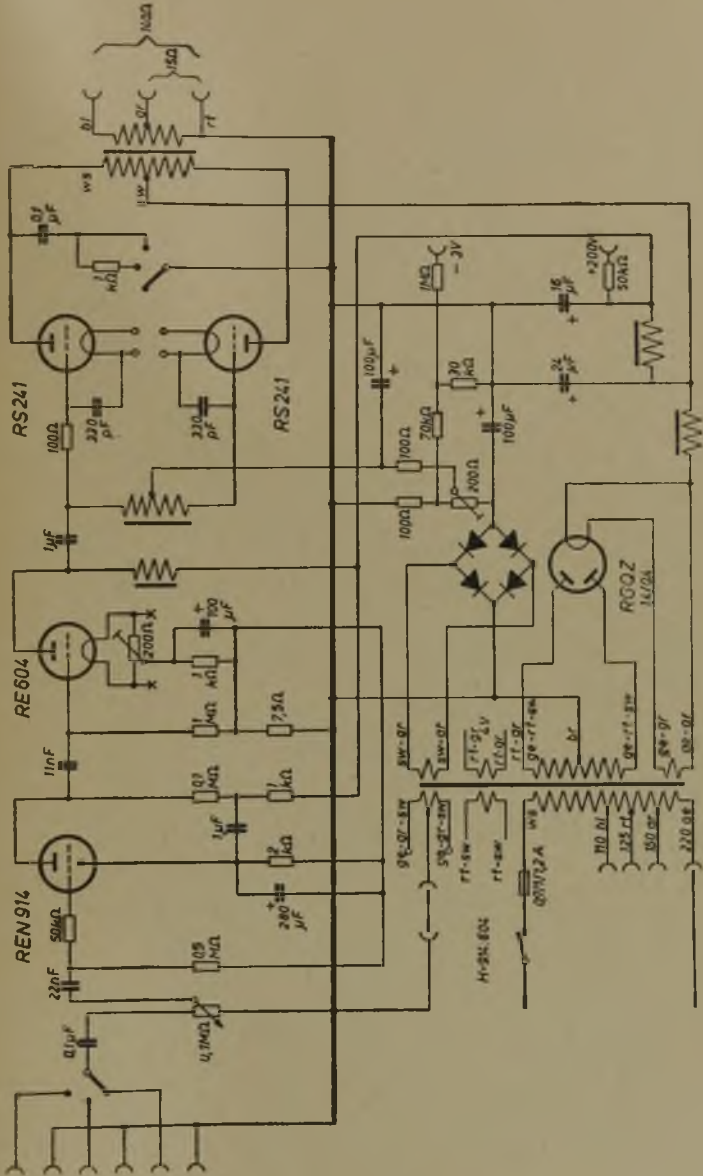

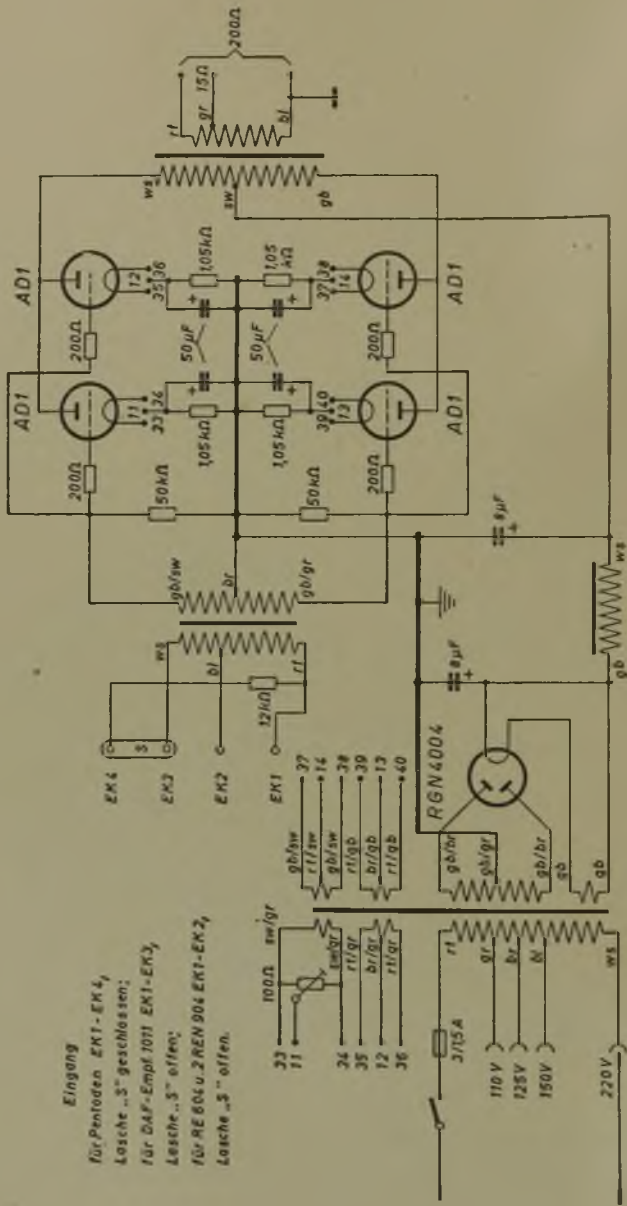

Eingang
für Pentoden EKT1-EKT4,
Lötlöte „S“ geschlossen;
für DAF-Empf 1011 EKT1-EKT3,
Lötlöte „S“ offen;
für RE 604 u. 2 REN 904 EKT1-EKT2,
Lötlöte „S“ offen.

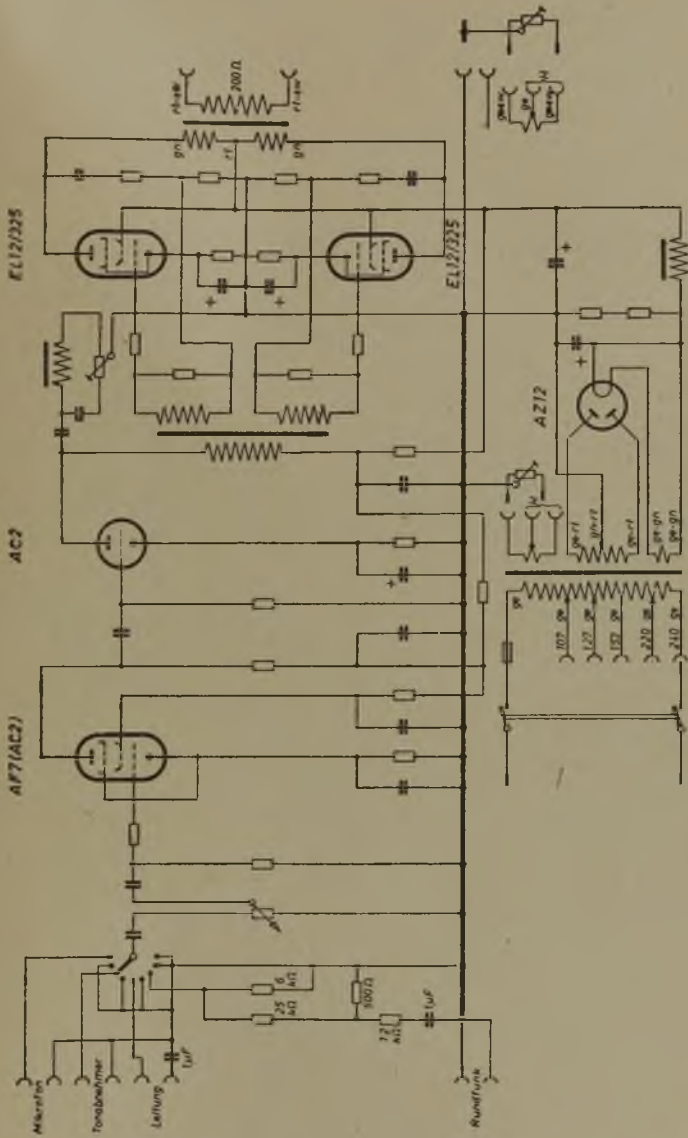

Siemens **SV 20/10 W** (20-Watt-Verstärker)

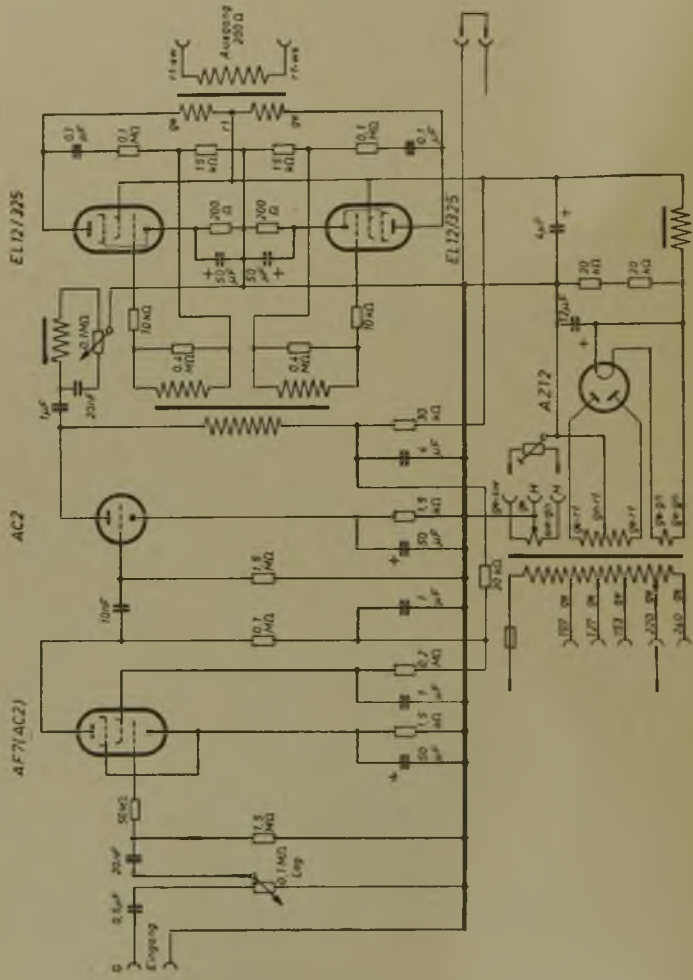

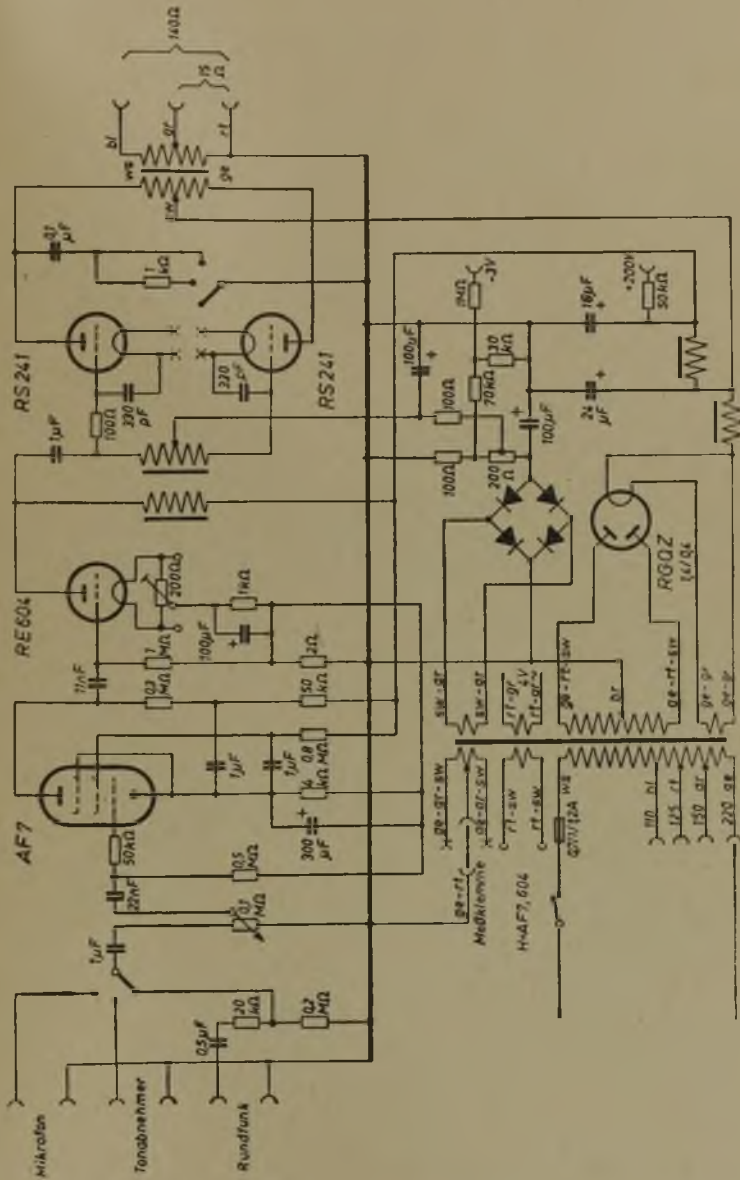

Siemens SV 20 bW (20-Watt-Verstärker)

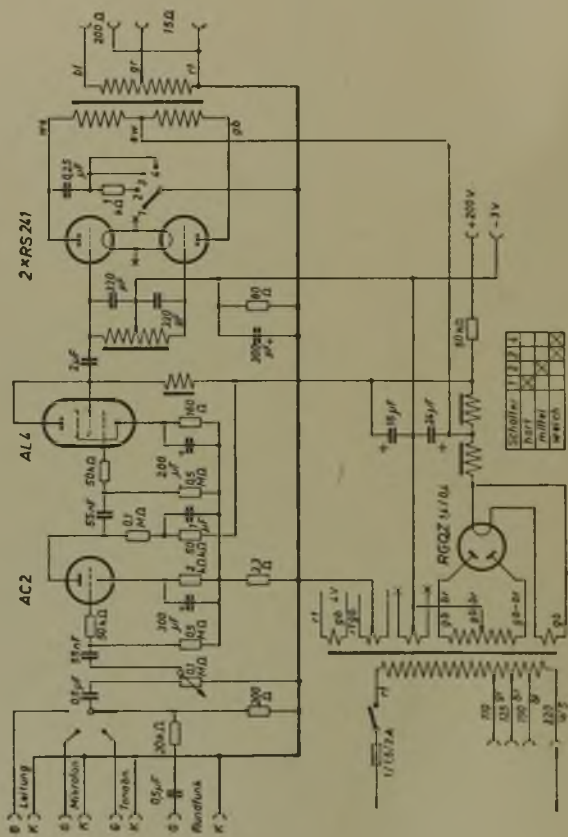

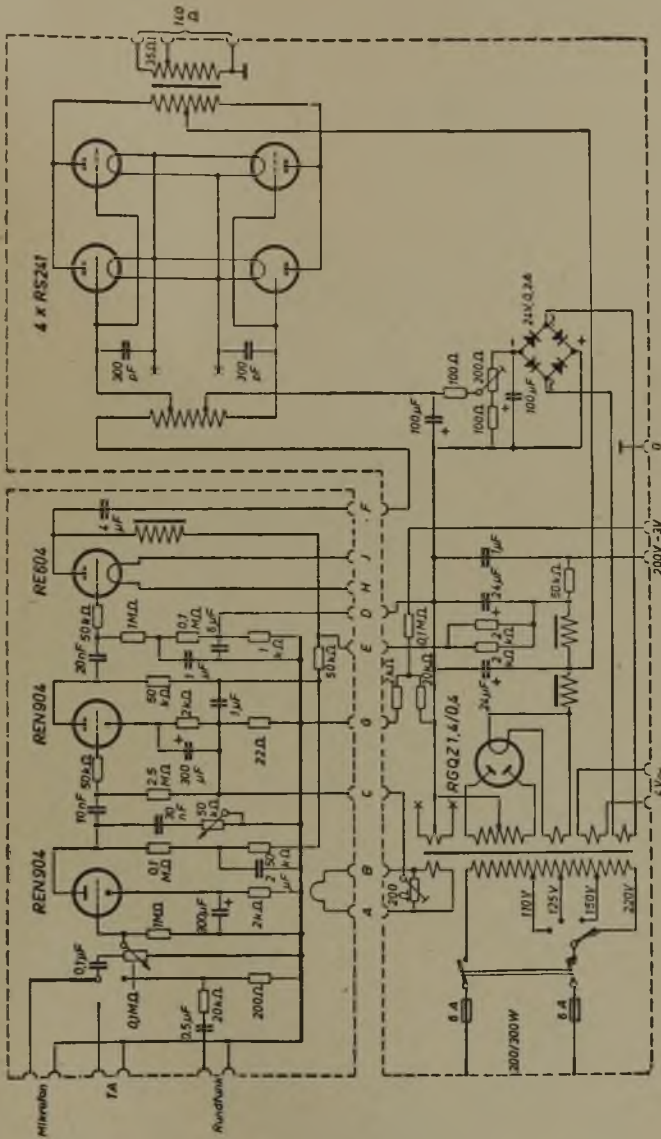

Siemens SV 70/1 W (70-Watt-Verstärker)

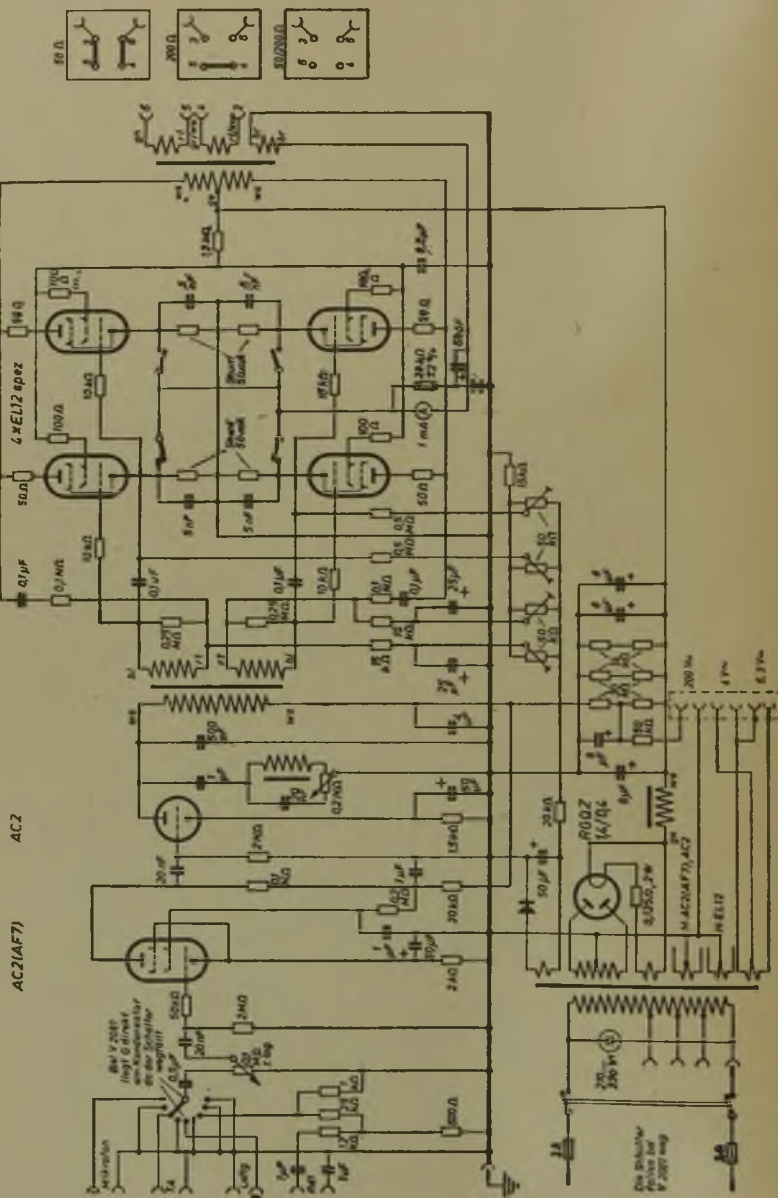

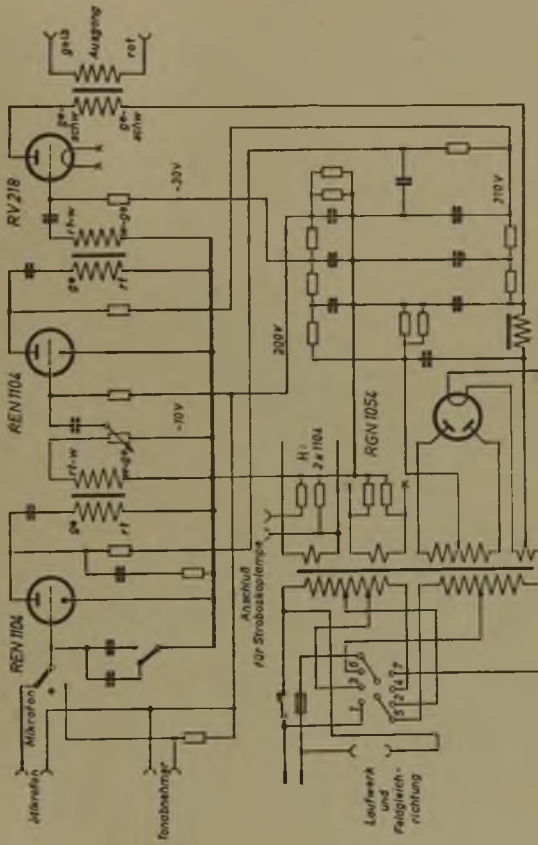

Siemens Elv 83 und 813

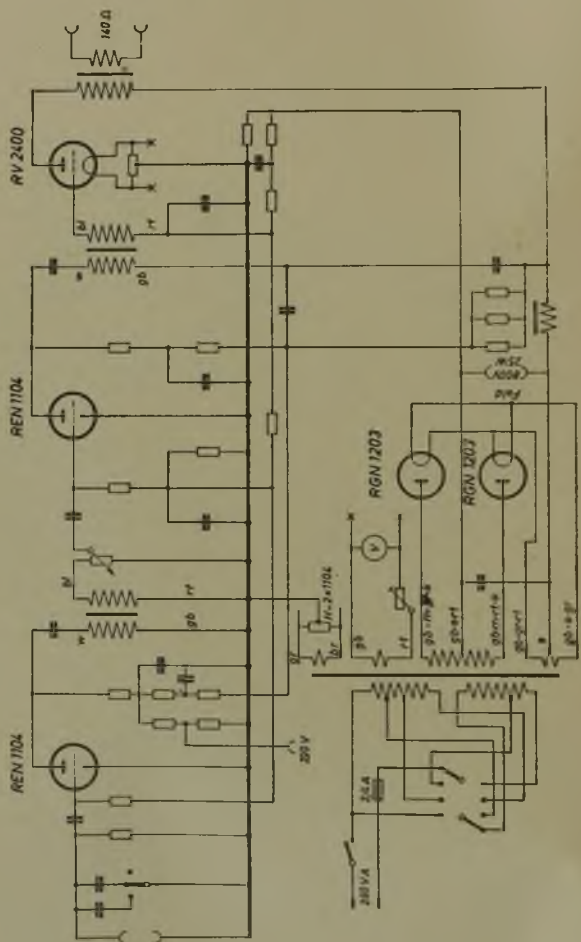

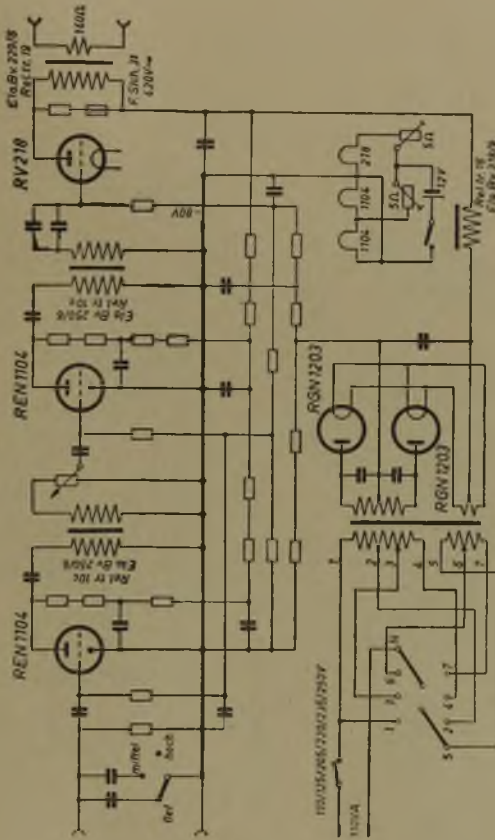

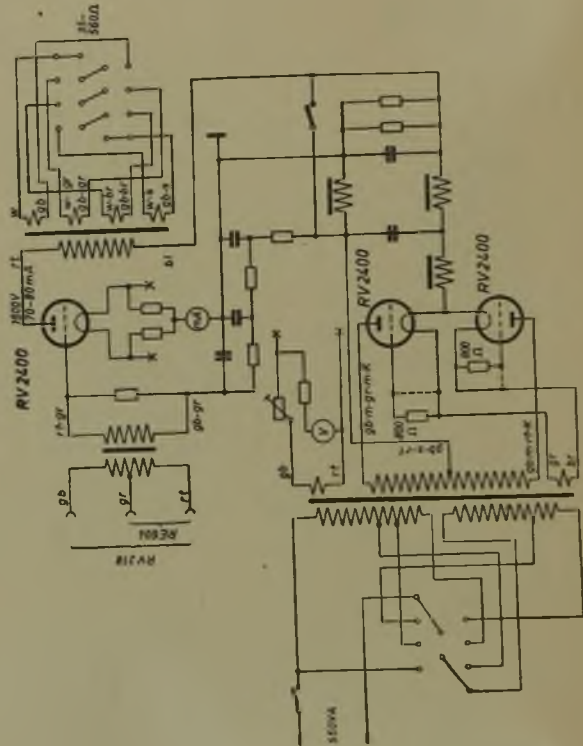

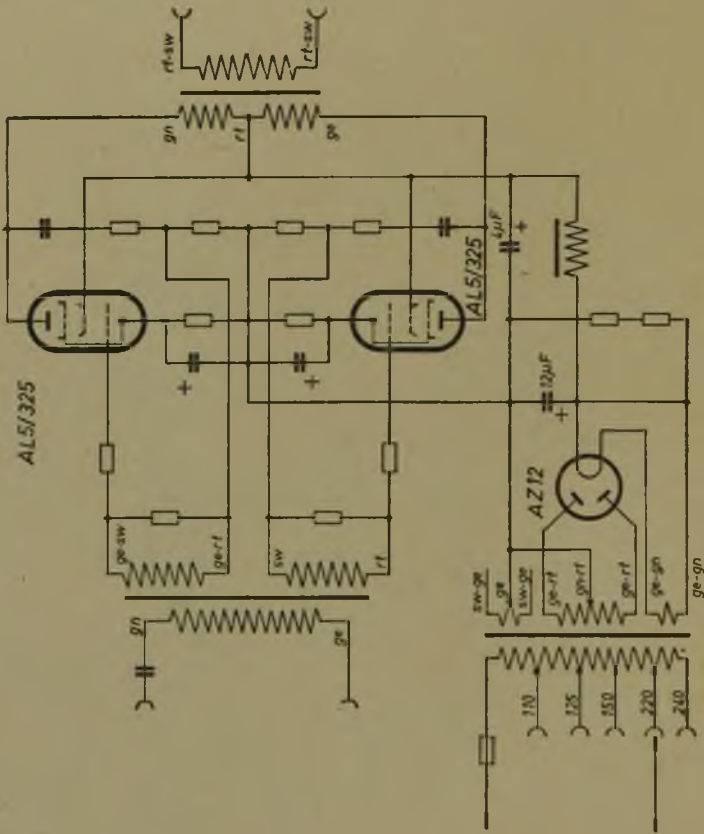

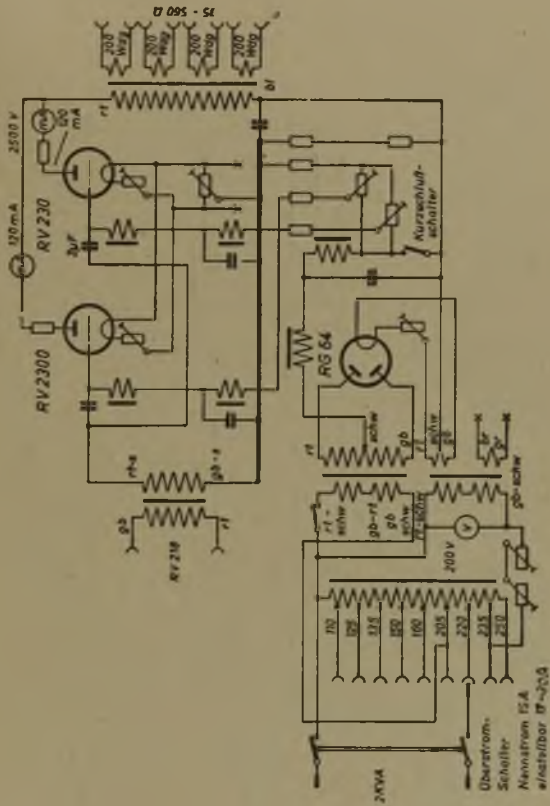

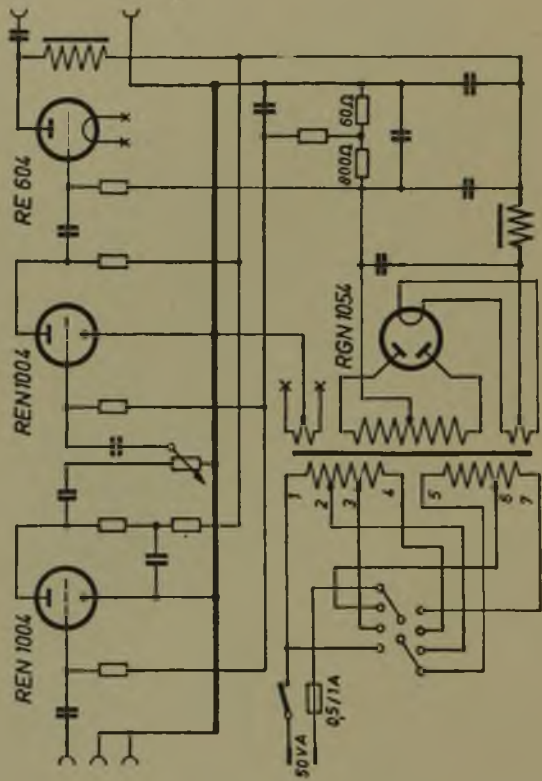

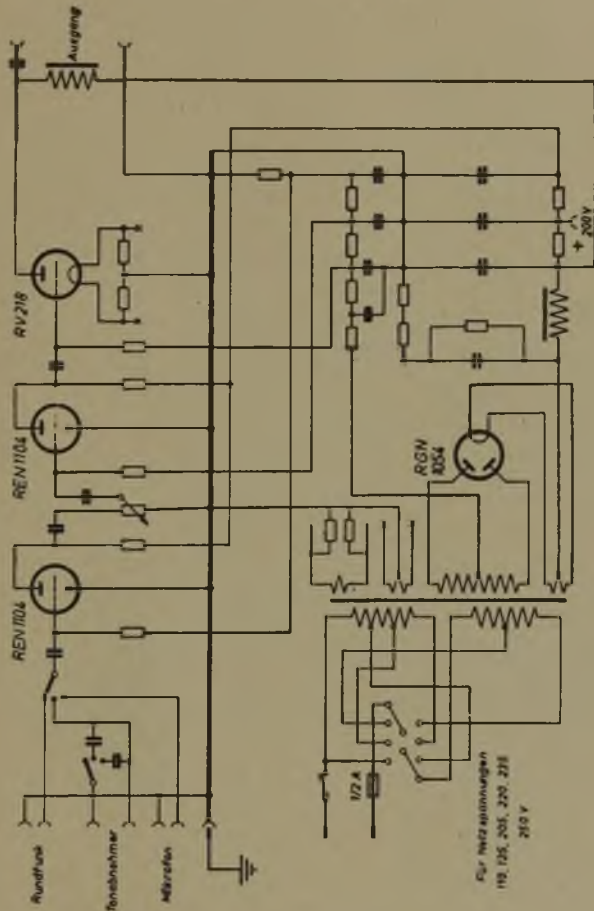

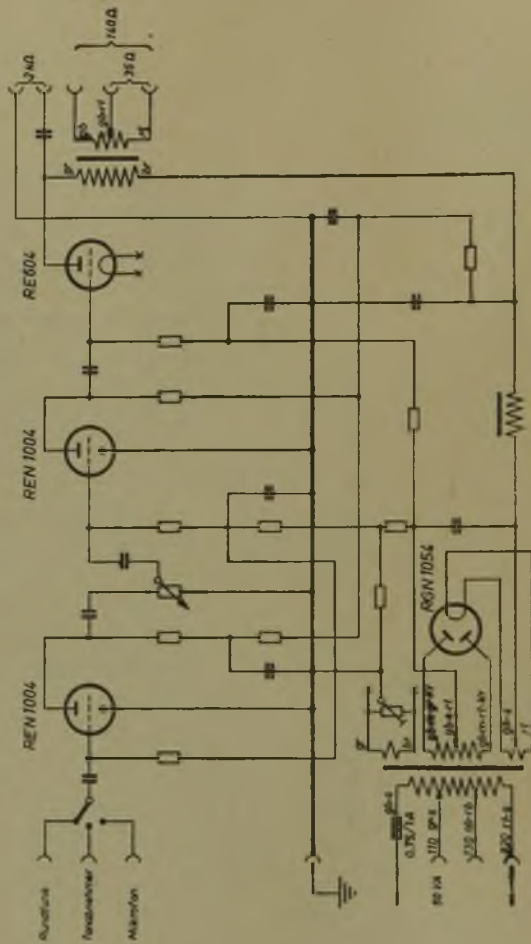

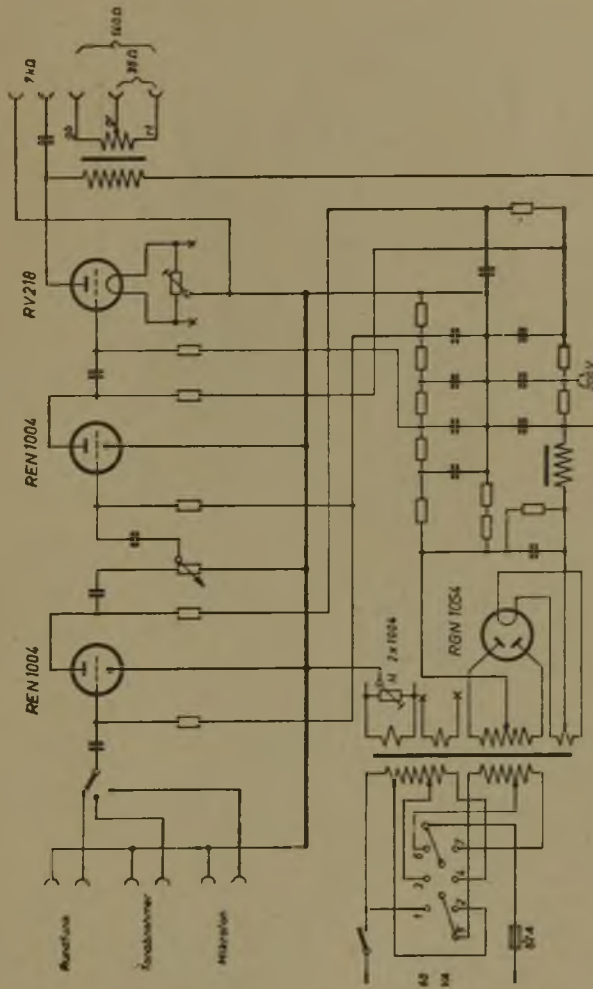

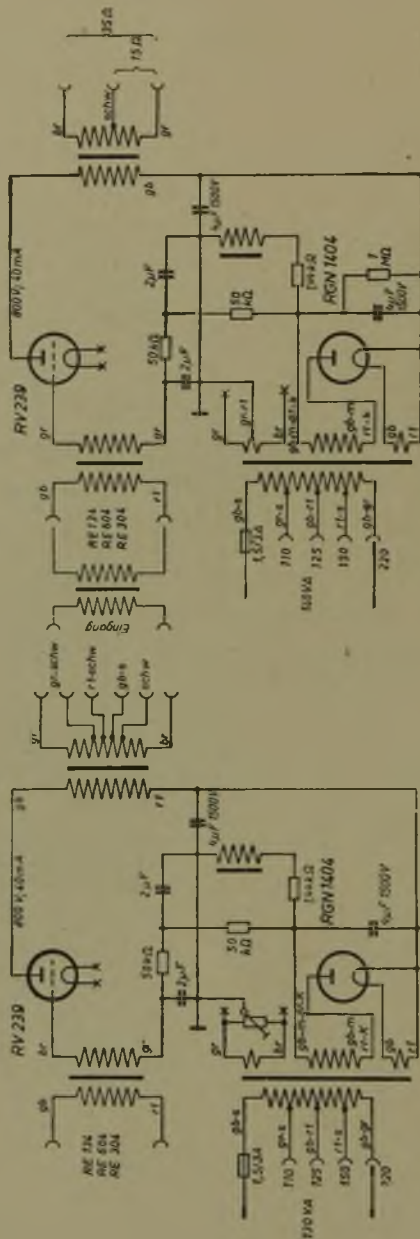

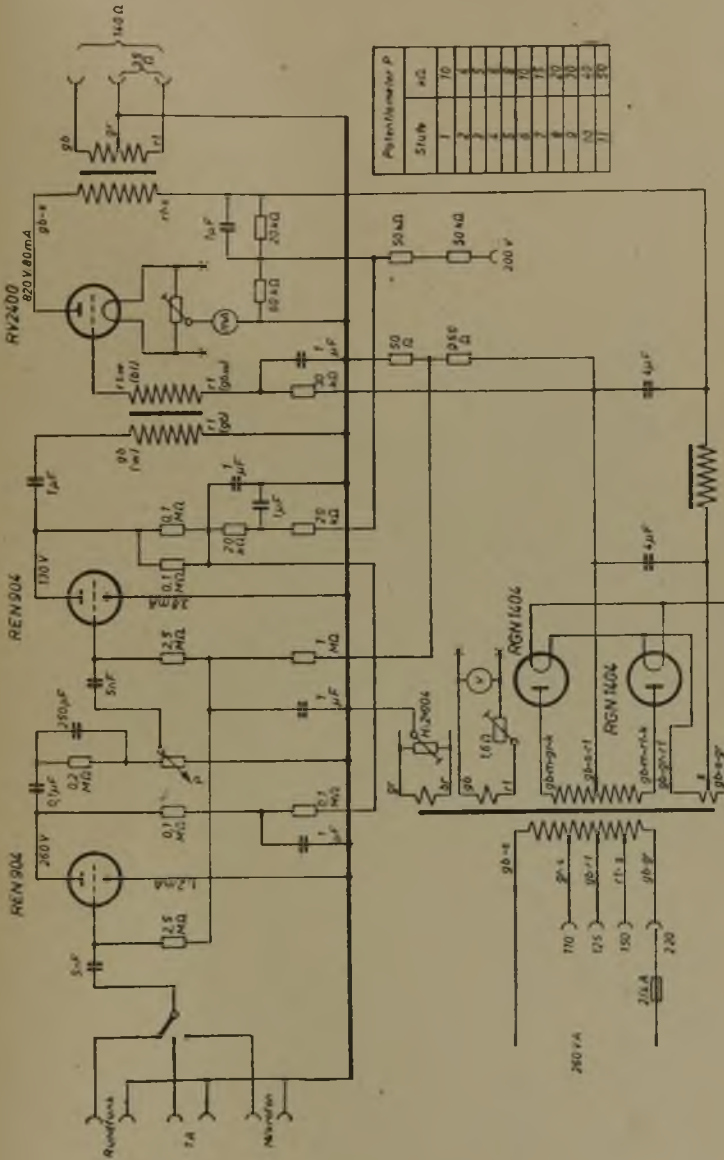

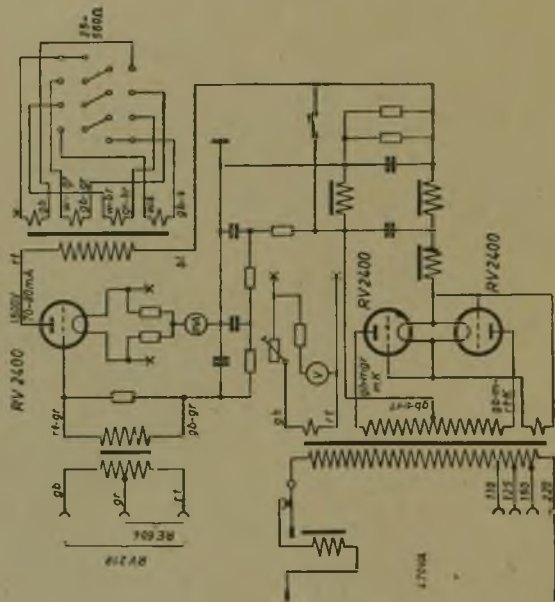

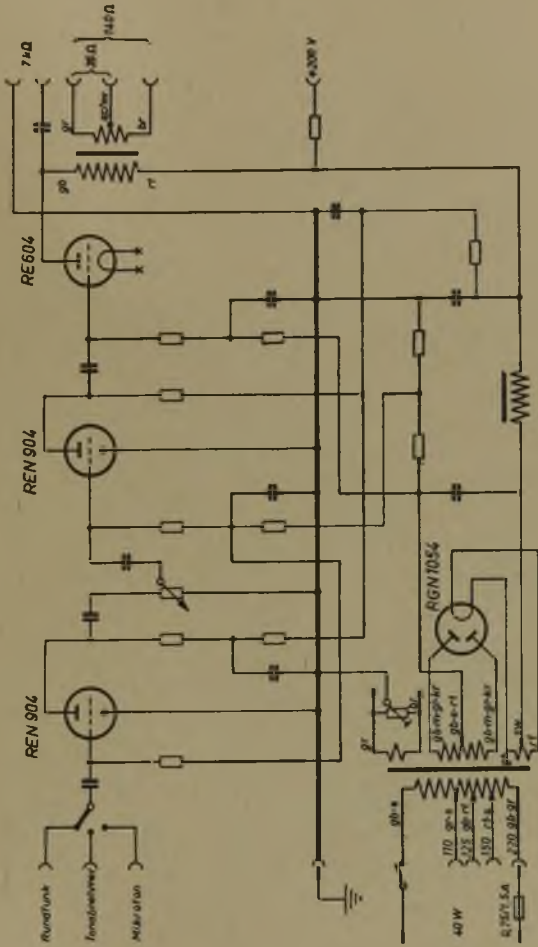

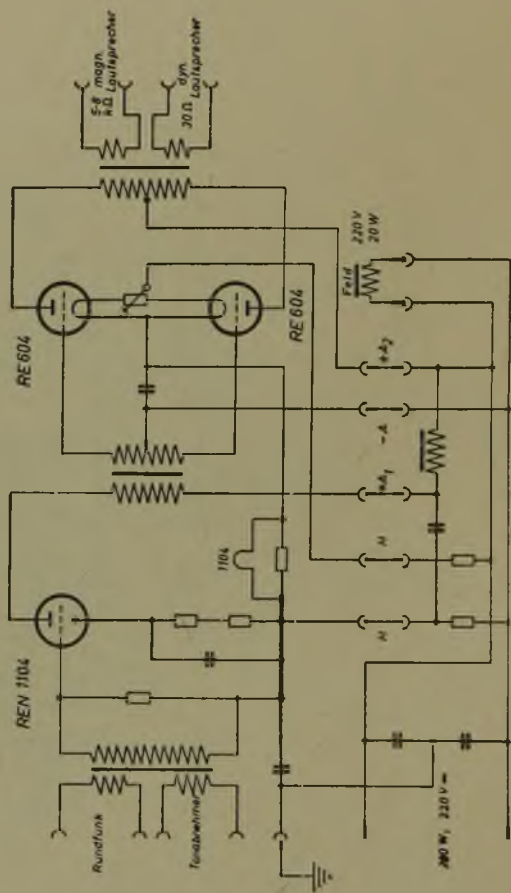

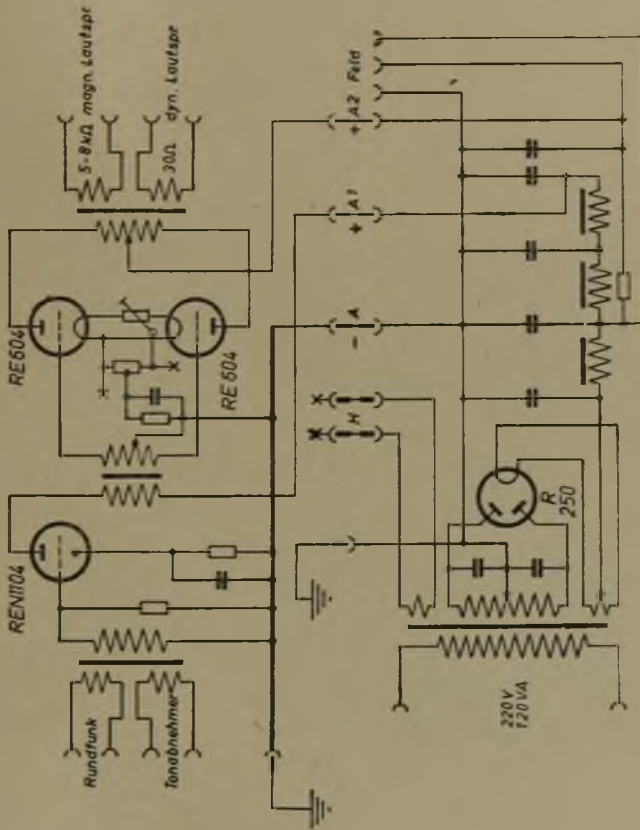

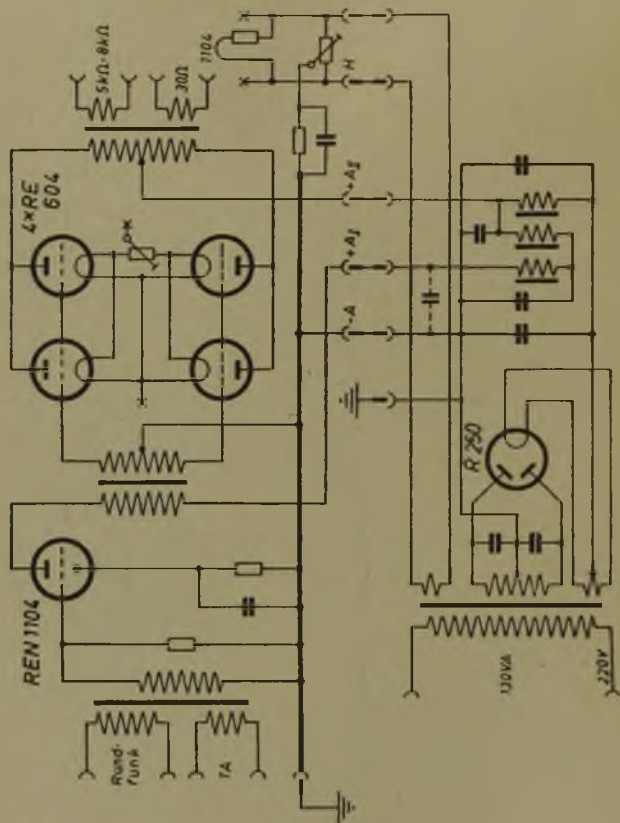

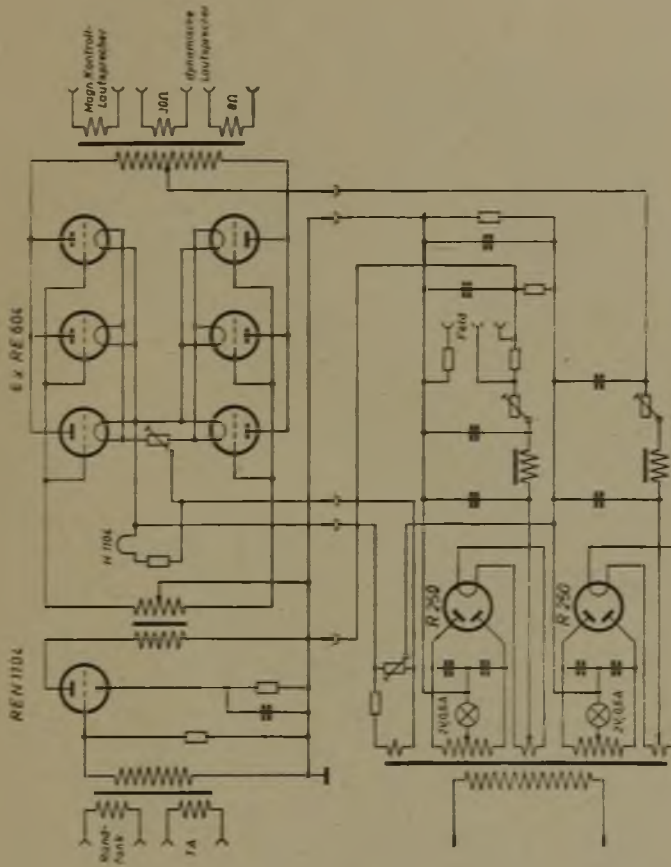

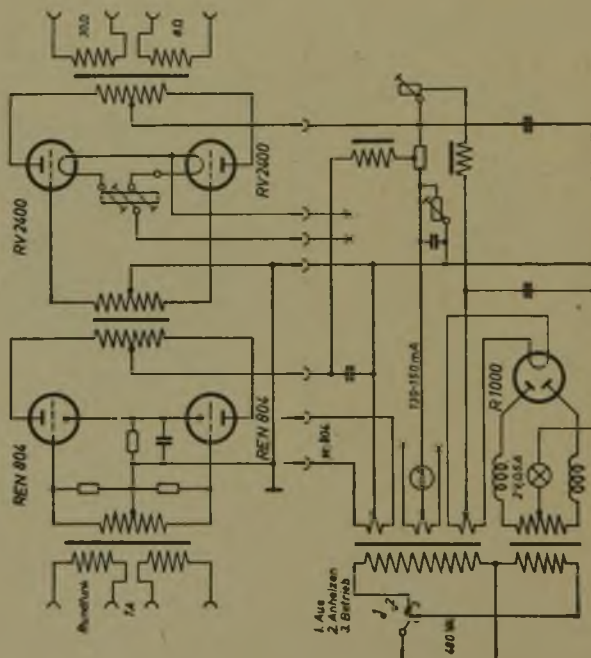
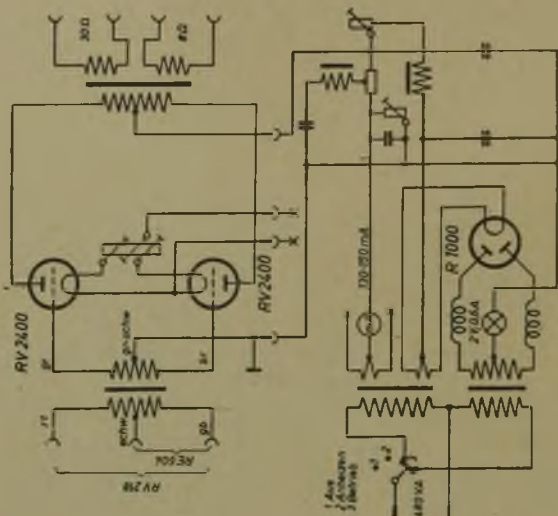

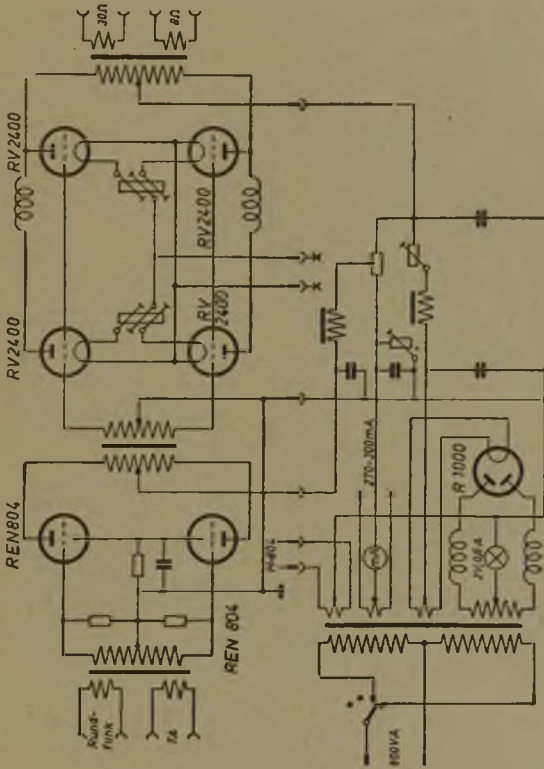

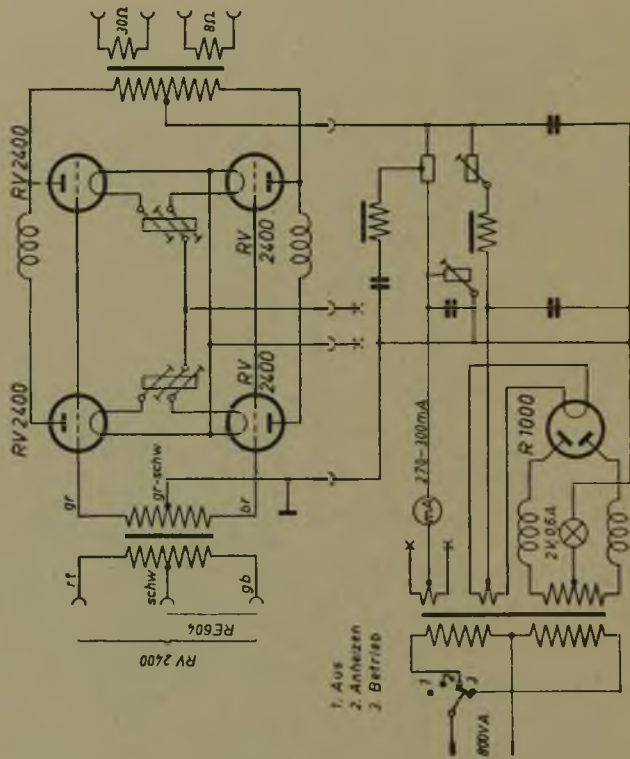

STAR
(Backnang)

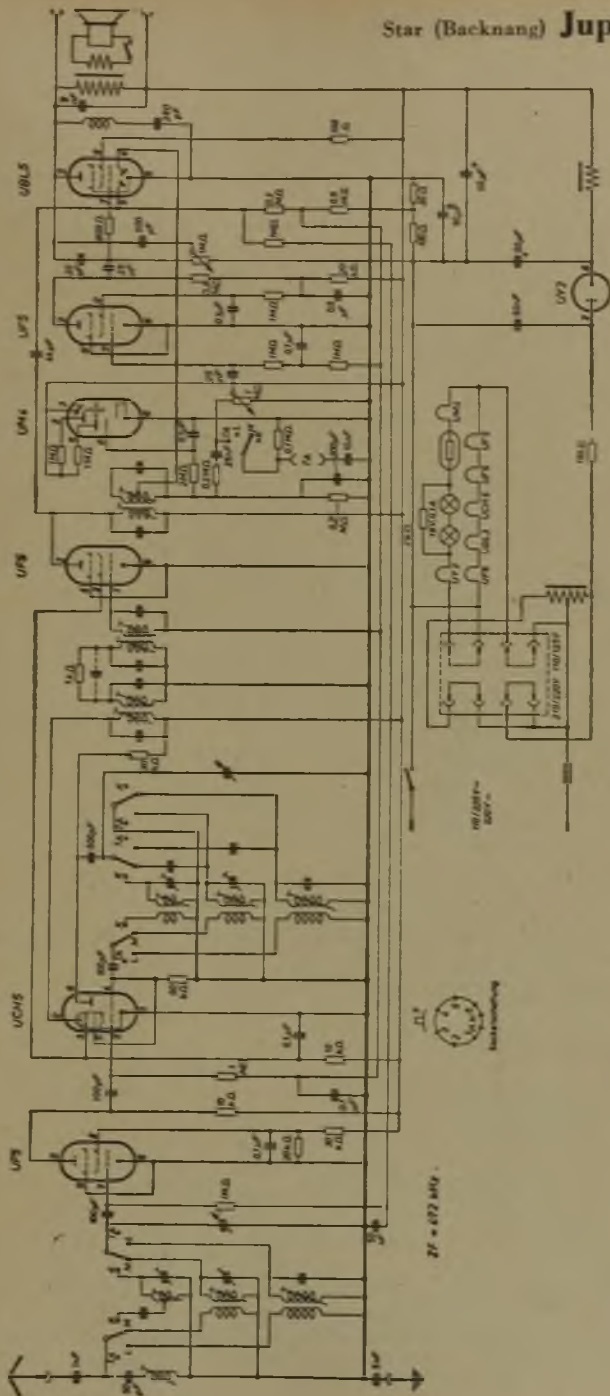

Star (Baeknang) Levante B

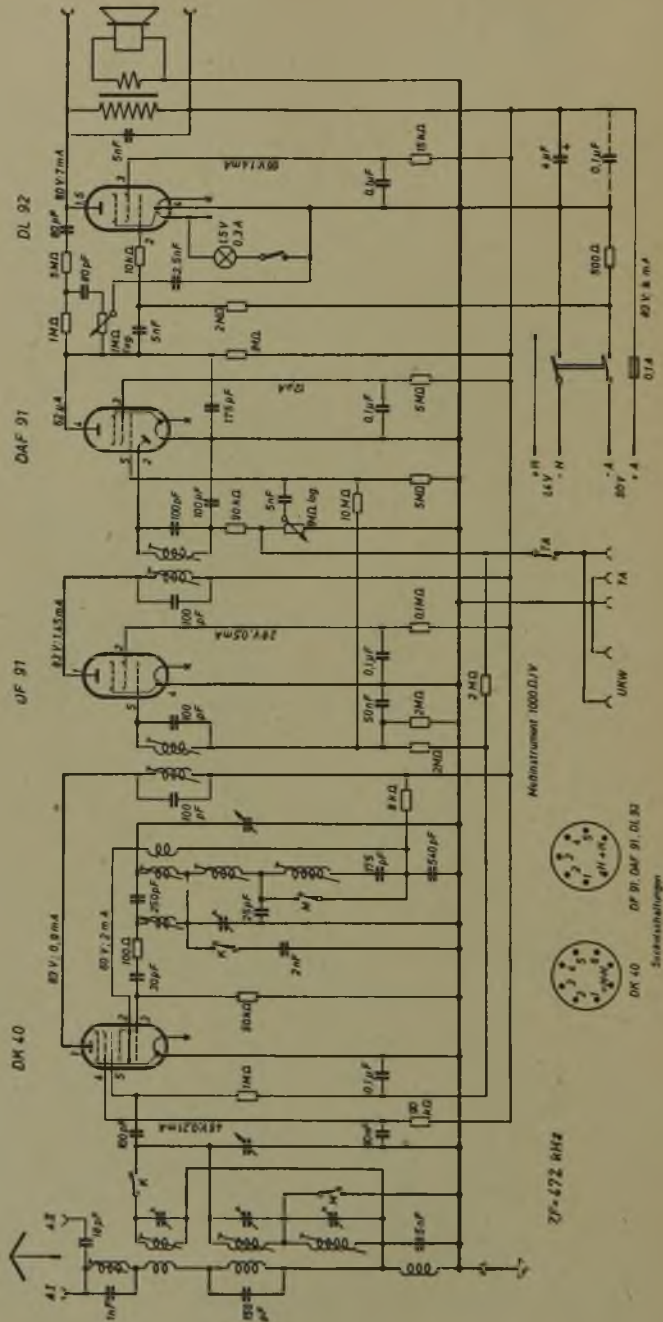

2F=472 kHz

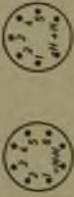

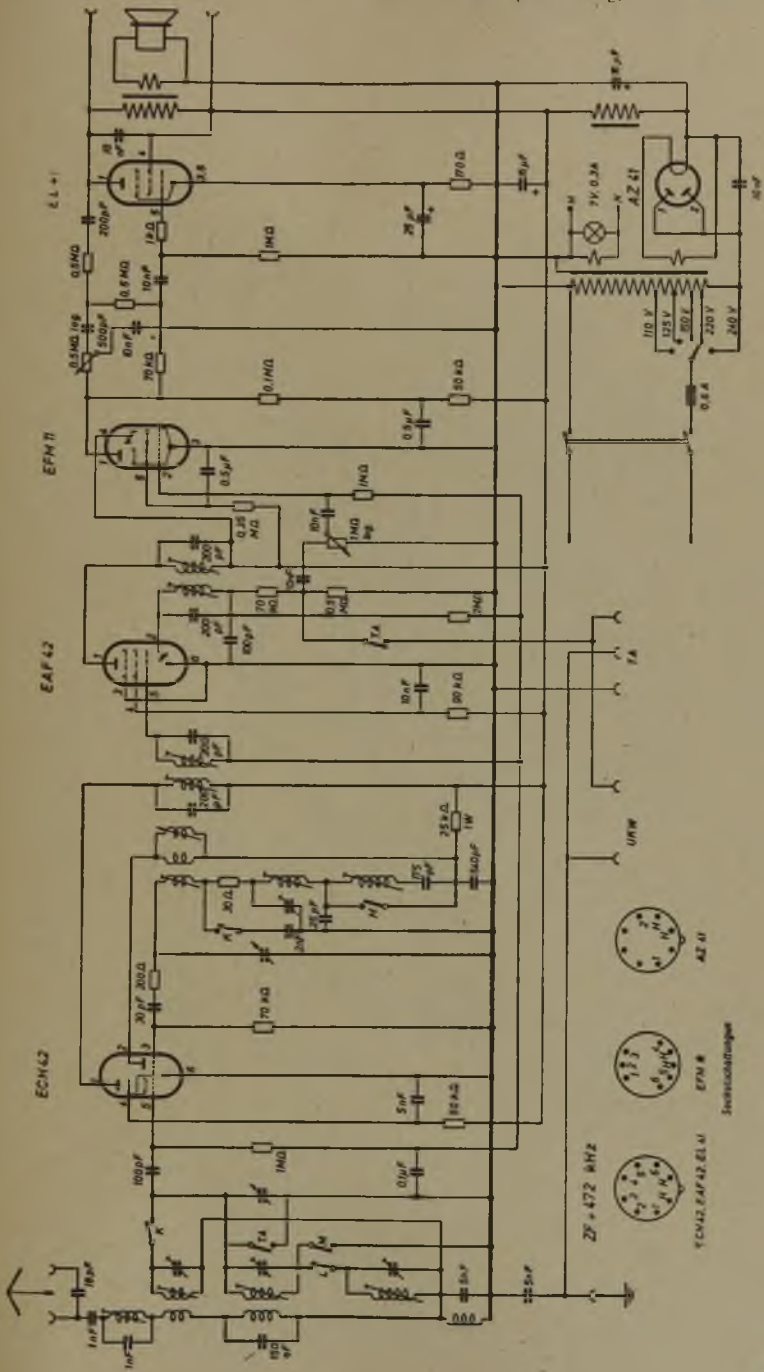

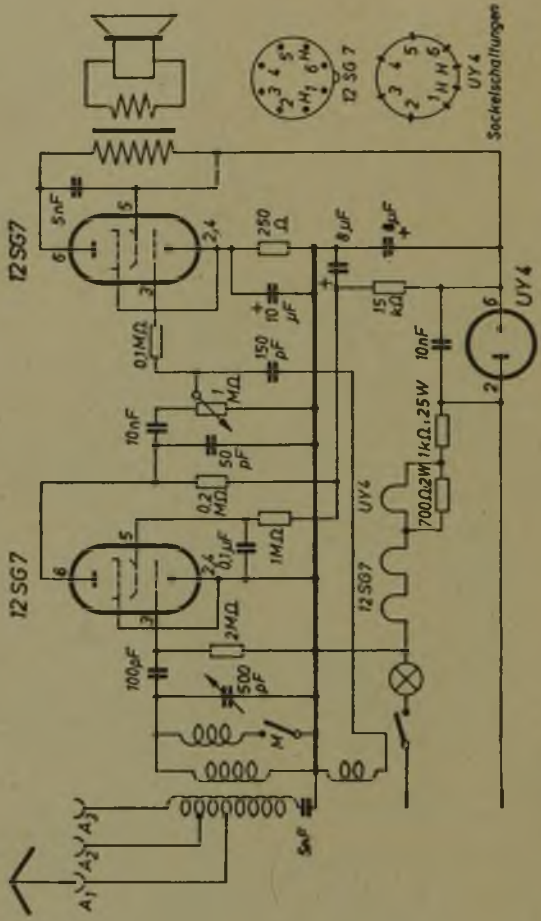

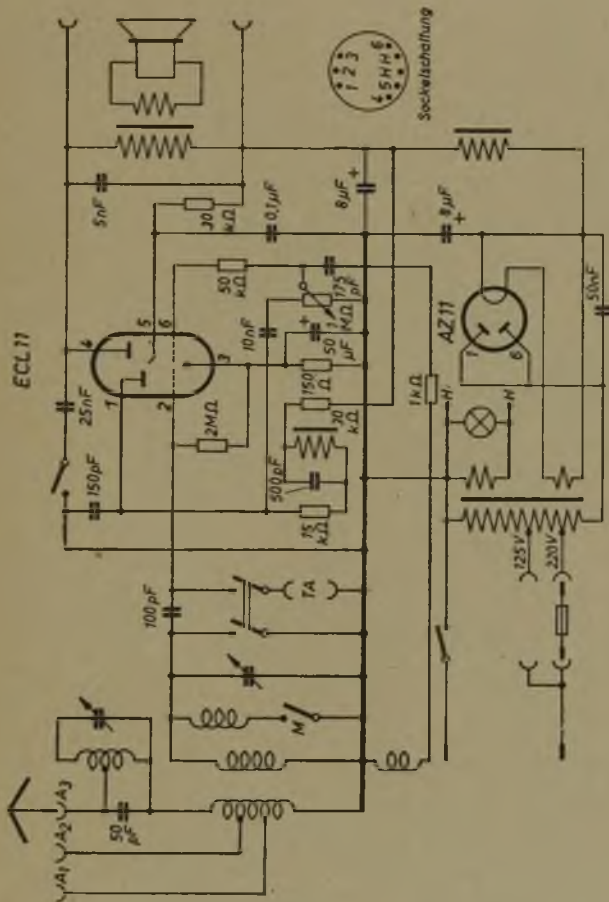

Star (Backang) Meteor

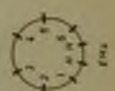
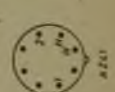
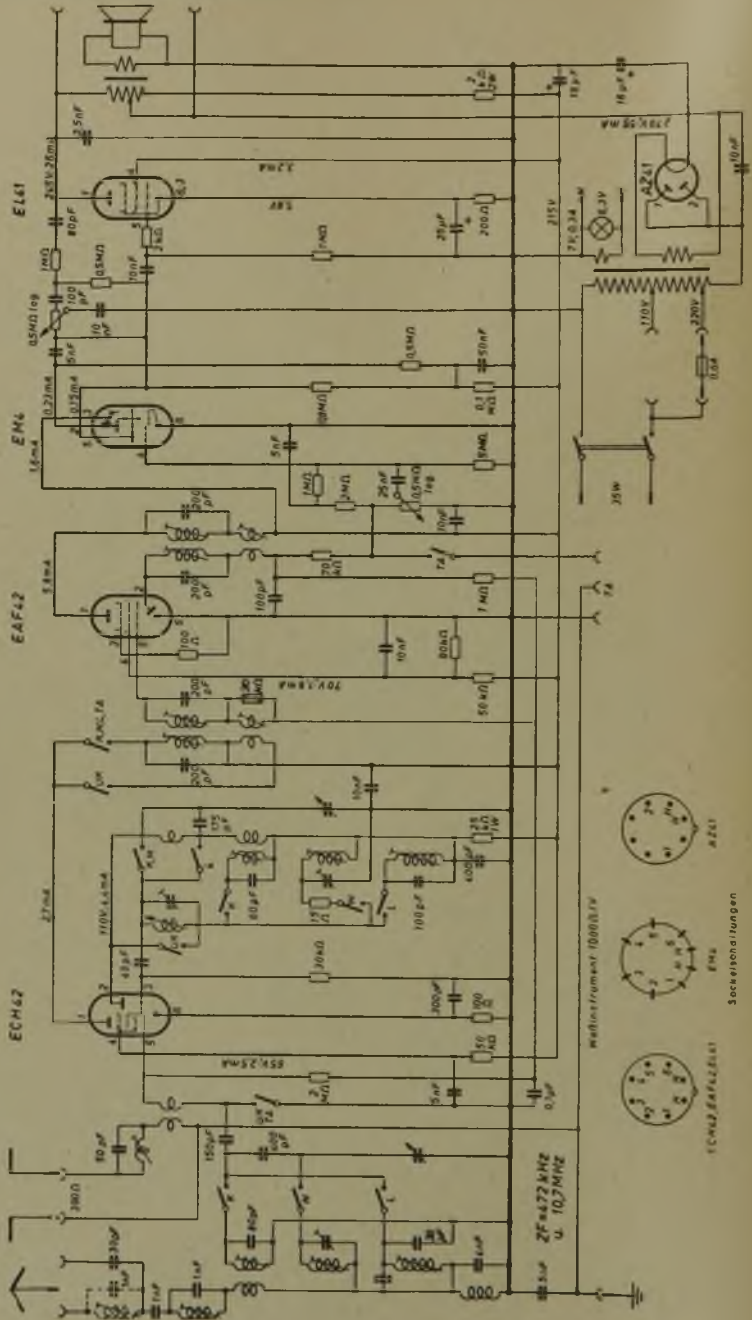

Solectronstrungen

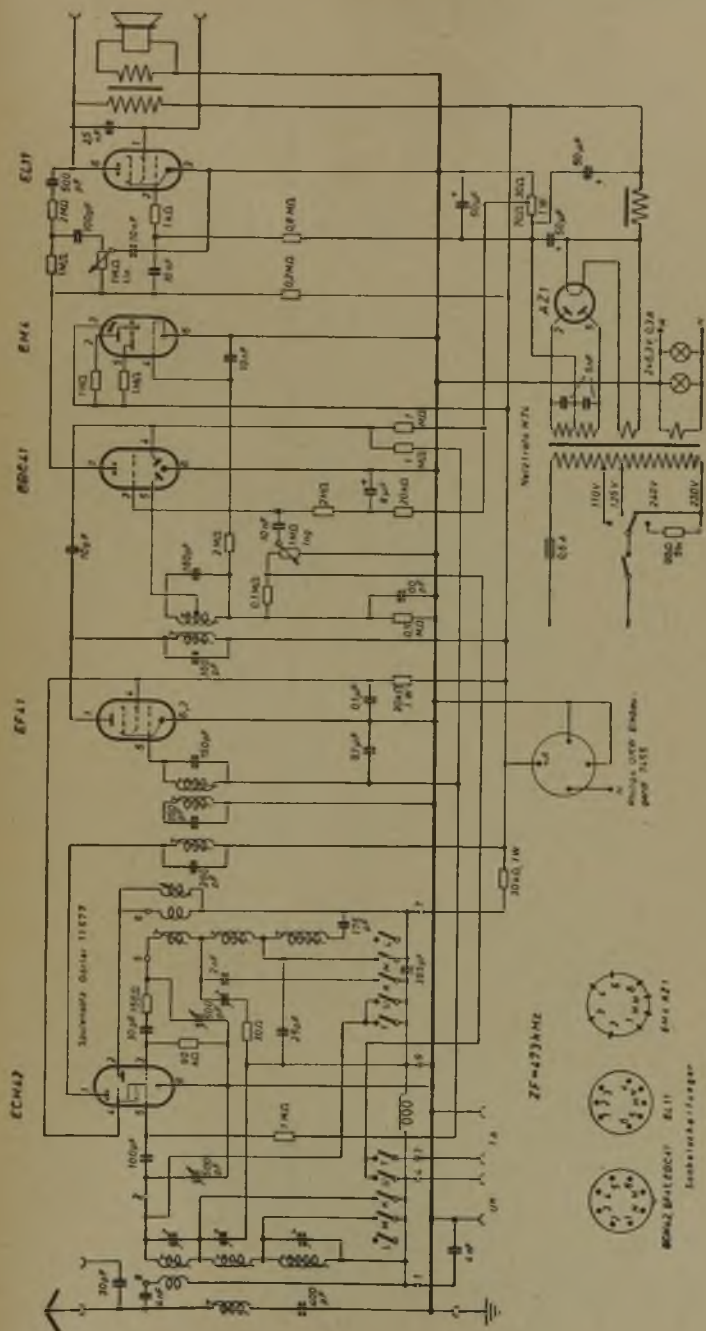

Star (Backang) Neptun 51 U

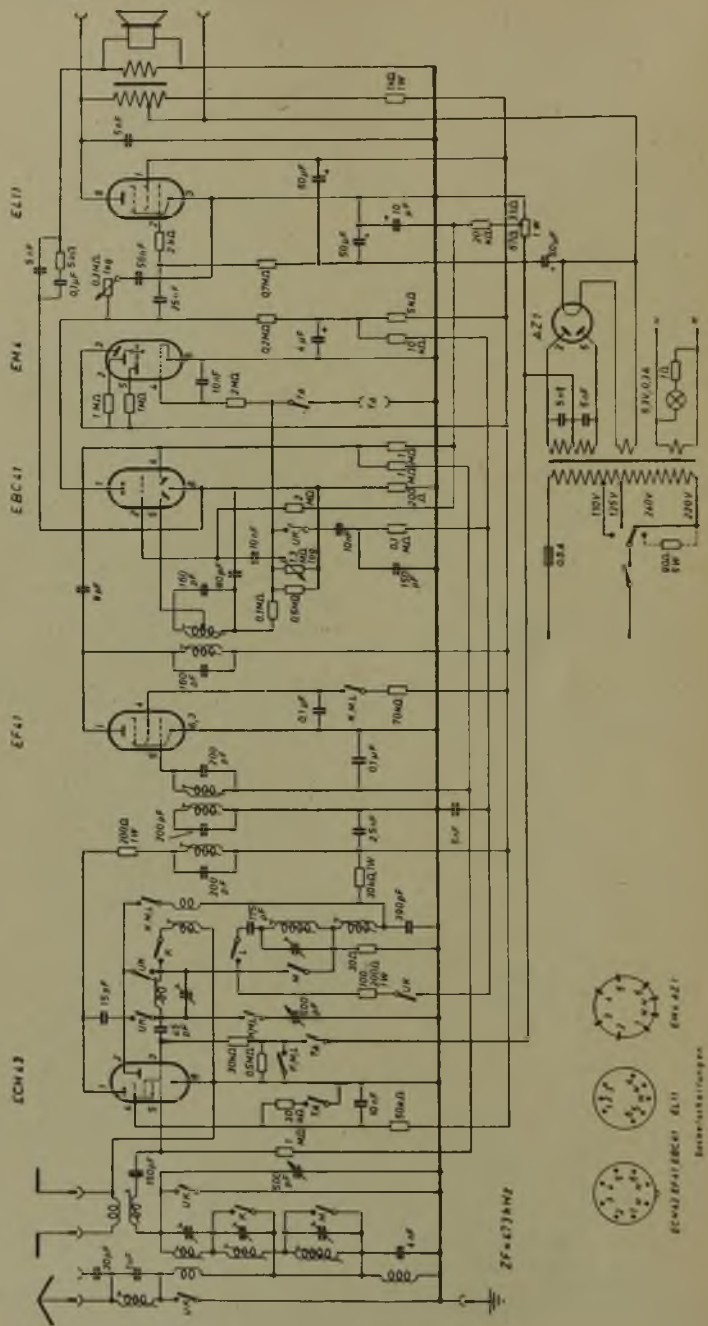

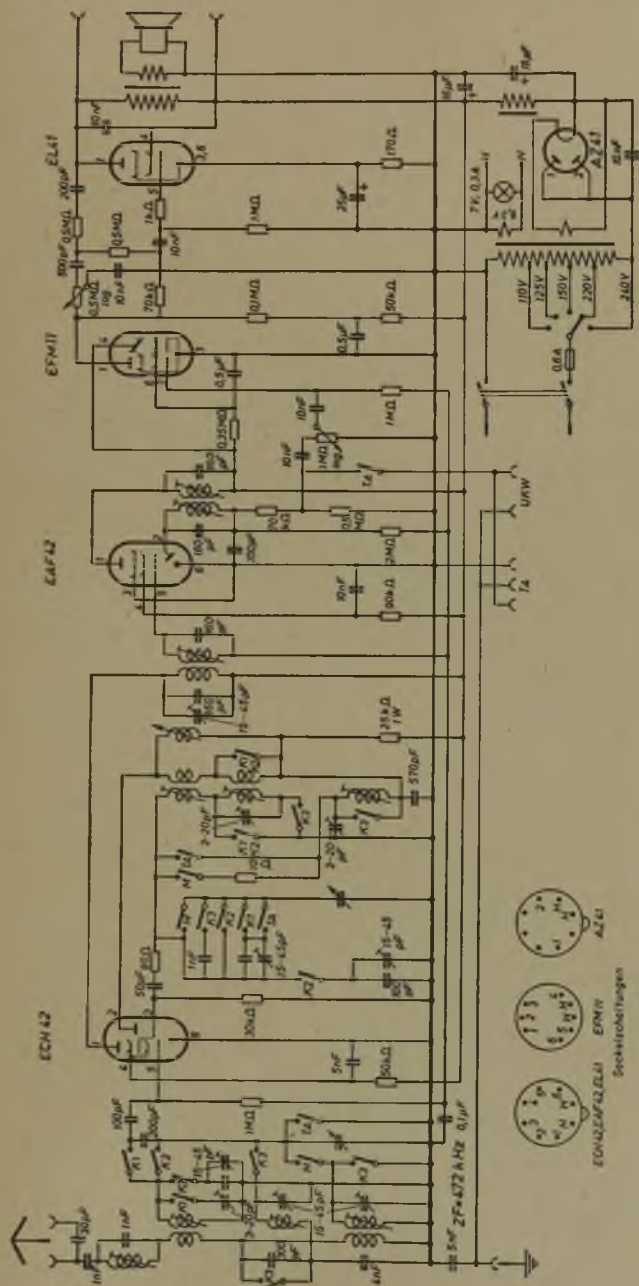

SOCKET CONNECTIONS

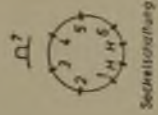
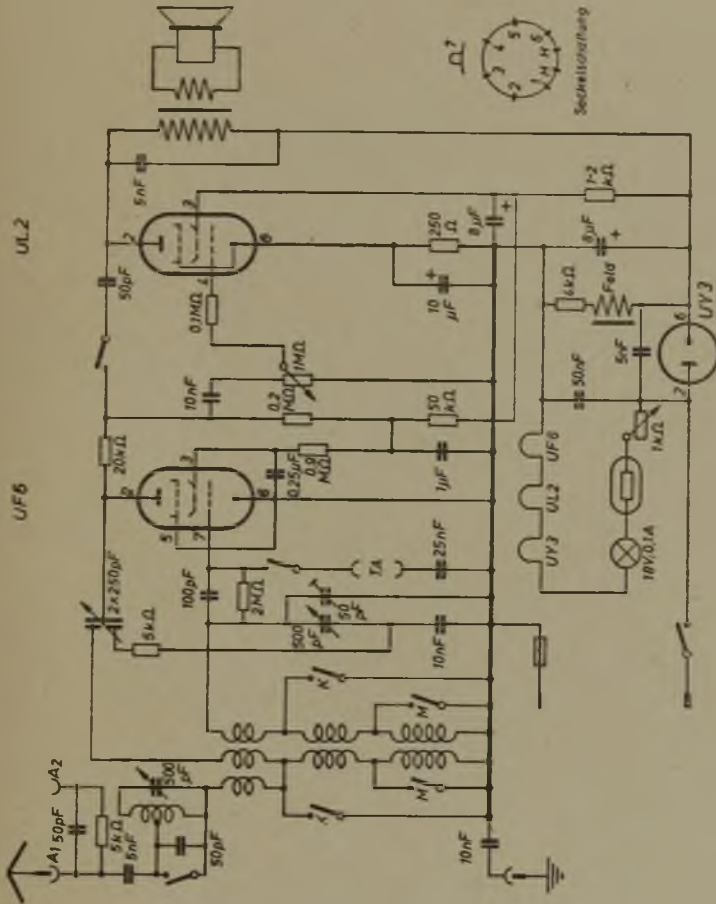

STASSFURT

Staßfurt Imperial 800 WK, 600 WK und 60 WK

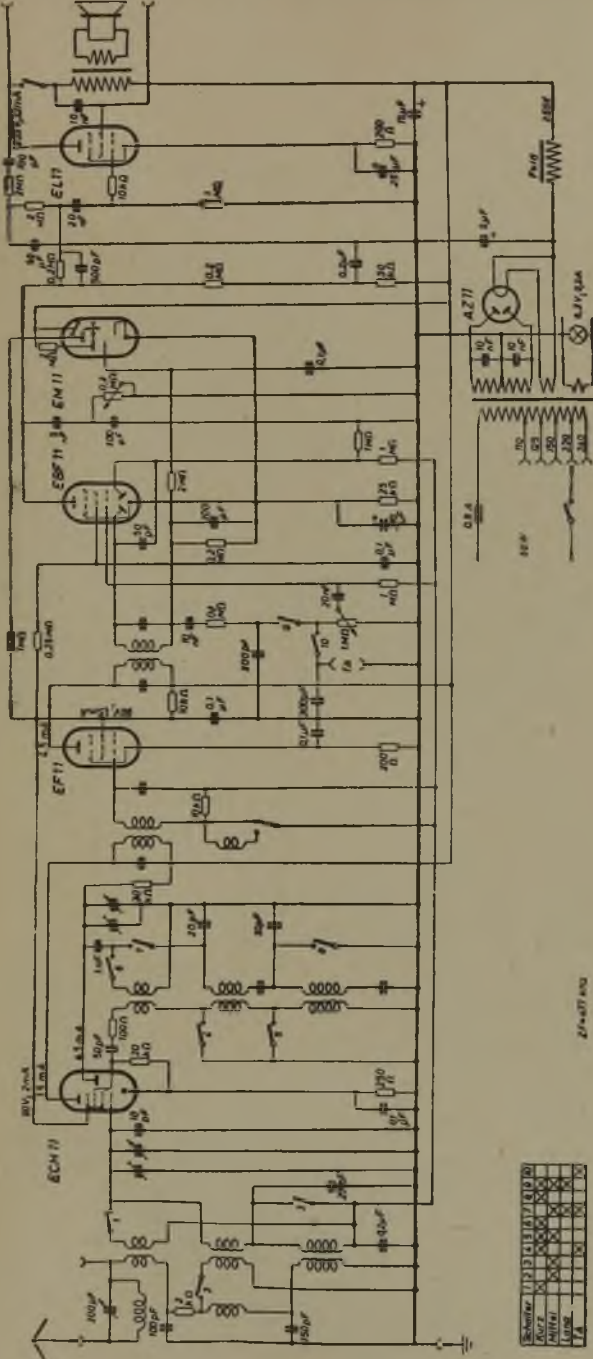

Stempeln	1	2	3	4	5	6	7	8	9	0
Ausg.										
Umsch.										
1/2										

Staßfurt Imperial 400 WK und 50 WK

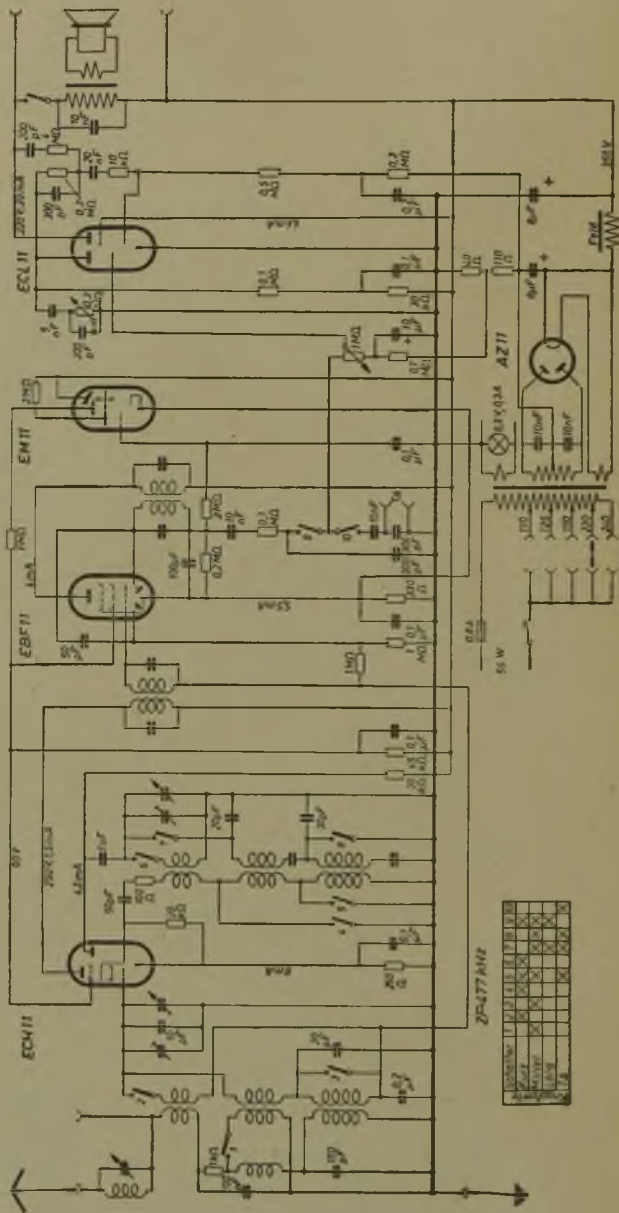

250kΩ 100kΩ

1	2	3	4	5	6	7	8	9	10
11	12	13	14	15	16	17	18	19	20
21	22	23	24	25	26	27	28	29	30
31	32	33	34	35	36	37	38	39	40

Stabfurt Imperial 98 W

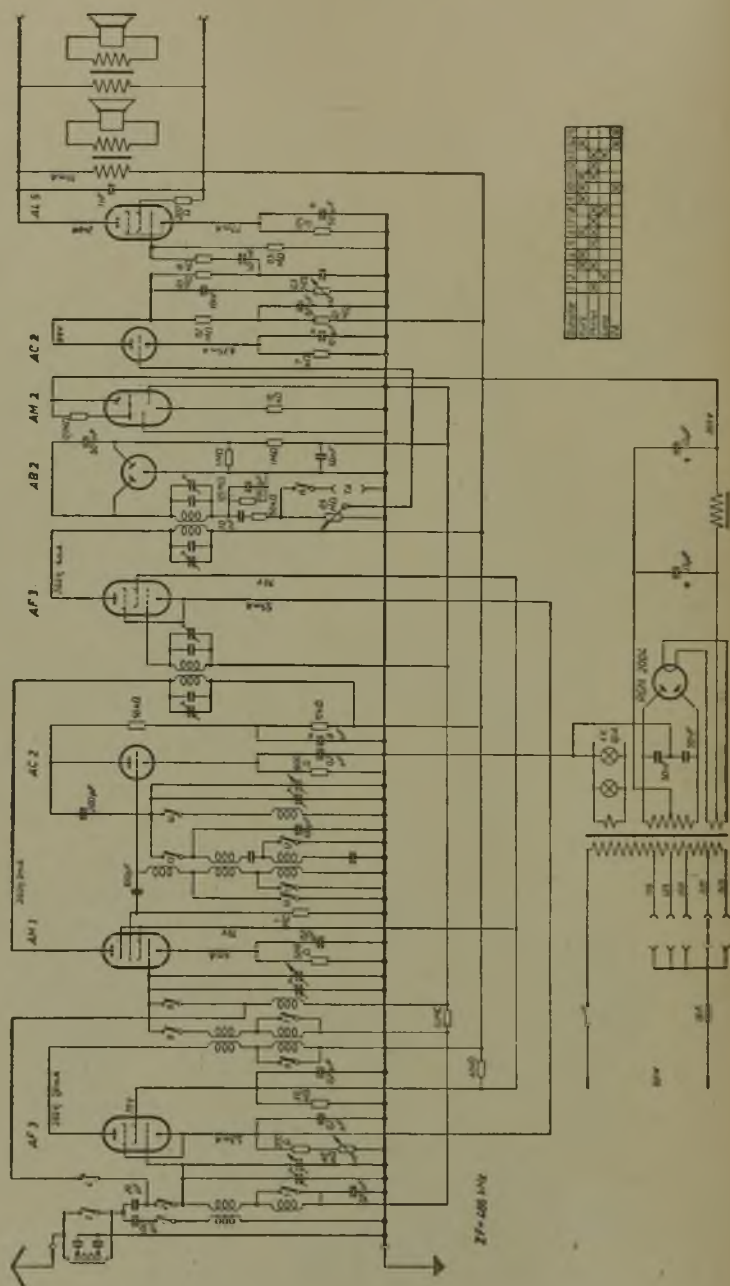

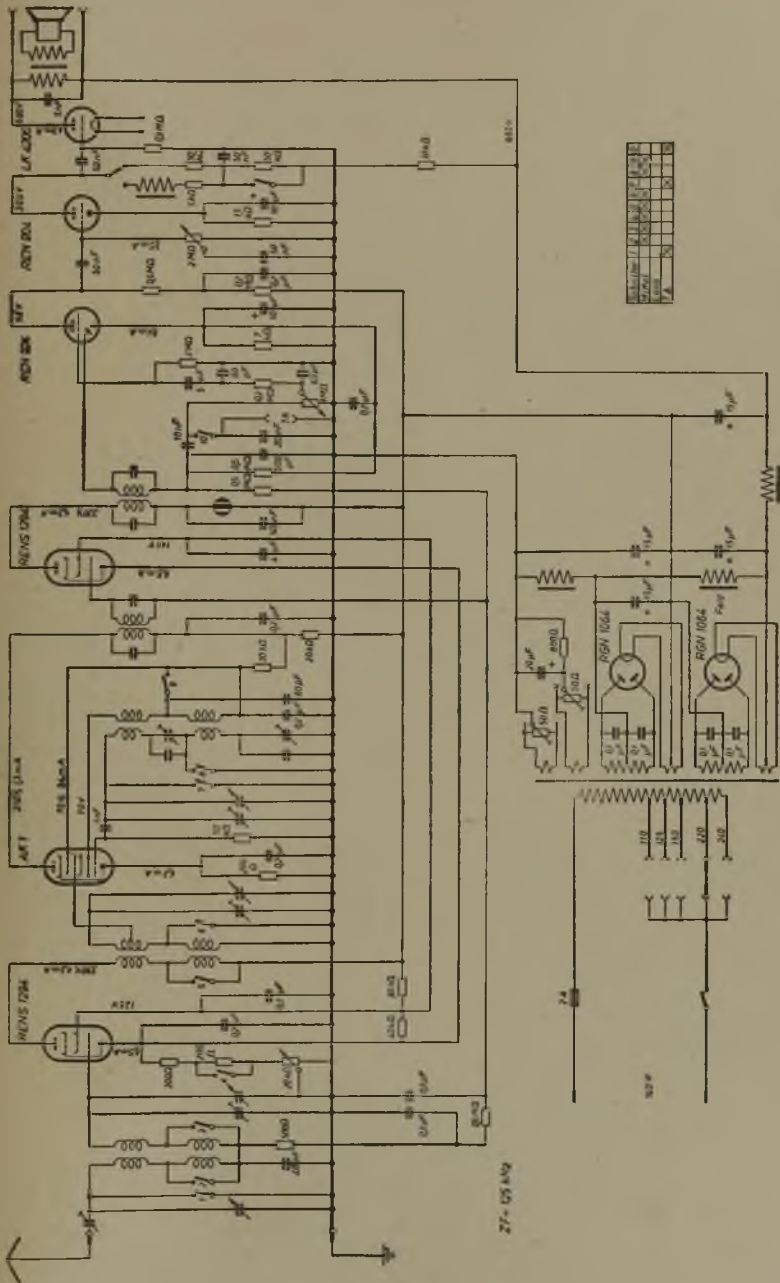

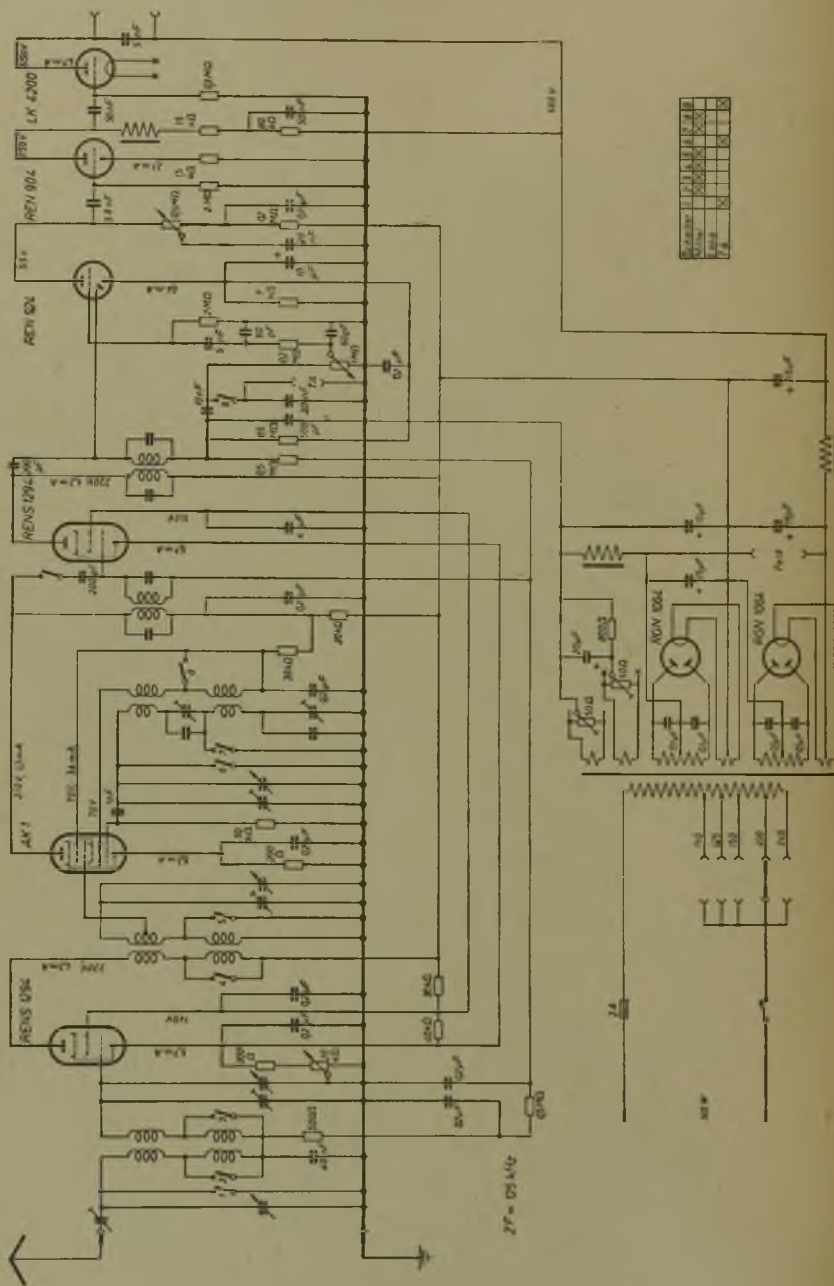

RENS 024	AK7	REVI 024	REVI 004	LK 4200	REVI 024	REVS 024
2000 K Ω	2000 K Ω	2000 K Ω	2000 K Ω	2000 K Ω	2000 K Ω	2000 K Ω
2000 K Ω	2000 K Ω	2000 K Ω	2000 K Ω	2000 K Ω	2000 K Ω	2000 K Ω
2000 K Ω	2000 K Ω	2000 K Ω	2000 K Ω	2000 K Ω	2000 K Ω	2000 K Ω
2000 K Ω	2000 K Ω	2000 K Ω	2000 K Ω	2000 K Ω	2000 K Ω	2000 K Ω

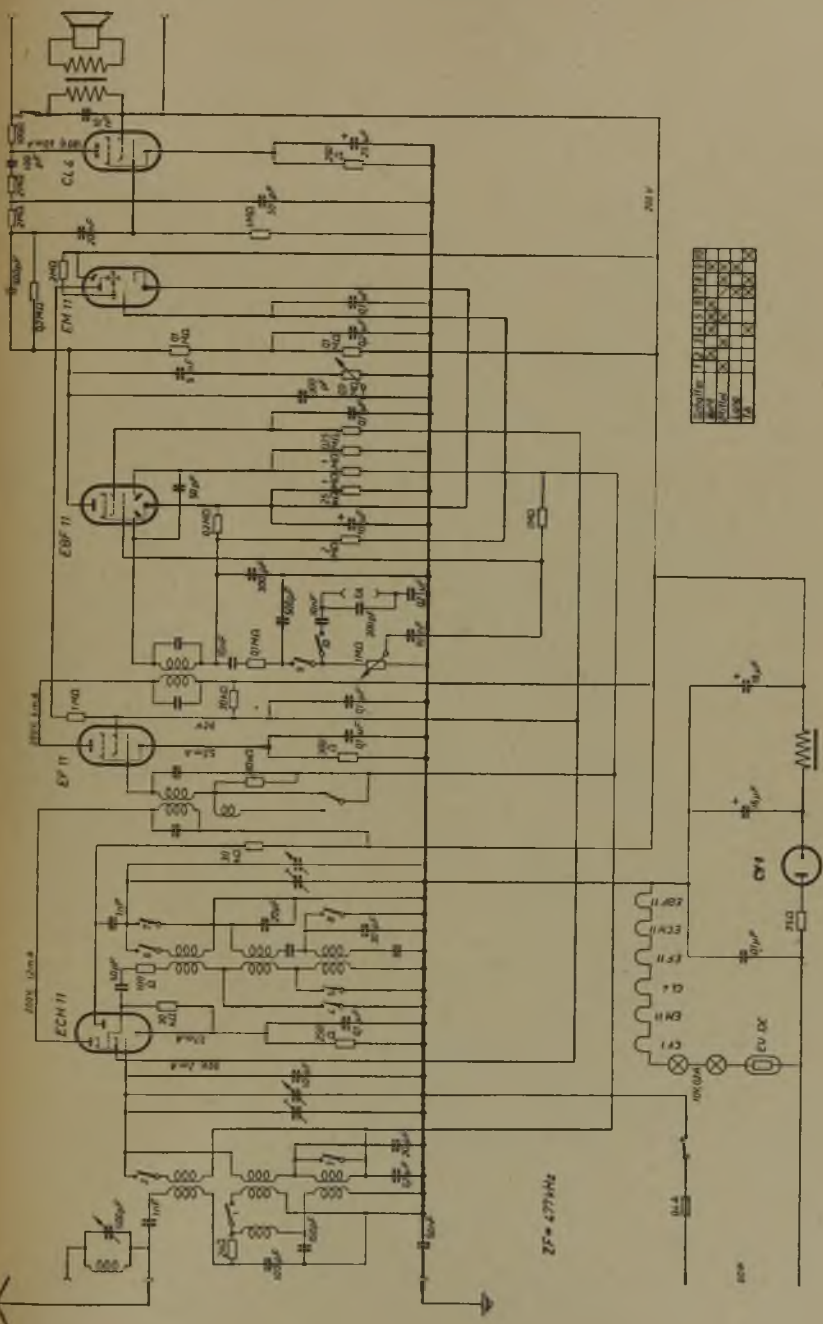

1	2	3	4	5	6	7	8	9	10	11	12	13	14	15	16	17	18	19	20	21	22	23	24	25	26	27	28	29	30	31	32	33	34	35	36	37	38	39	40	41	42	43	44	45	46	47	48	49	50	51	52	53	54	55	56	57	58	59	60	61	62	63	64	65	66	67	68	69	70	71	72	73	74	75	76	77	78	79	80	81	82	83	84	85	86	87	88	89	90	91	92	93	94	95	96	97	98	99	100
---	---	---	---	---	---	---	---	---	----	----	----	----	----	----	----	----	----	----	----	----	----	----	----	----	----	----	----	----	----	----	----	----	----	----	----	----	----	----	----	----	----	----	----	----	----	----	----	----	----	----	----	----	----	----	----	----	----	----	----	----	----	----	----	----	----	----	----	----	----	----	----	----	----	----	----	----	----	----	----	----	----	----	----	----	----	----	----	----	----	----	----	----	----	----	----	----	----	----	-----

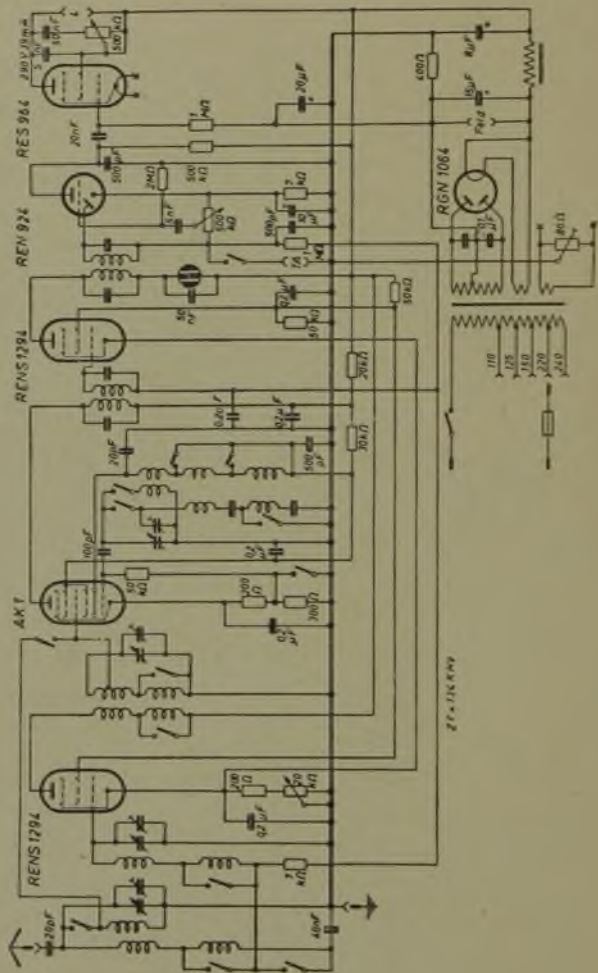

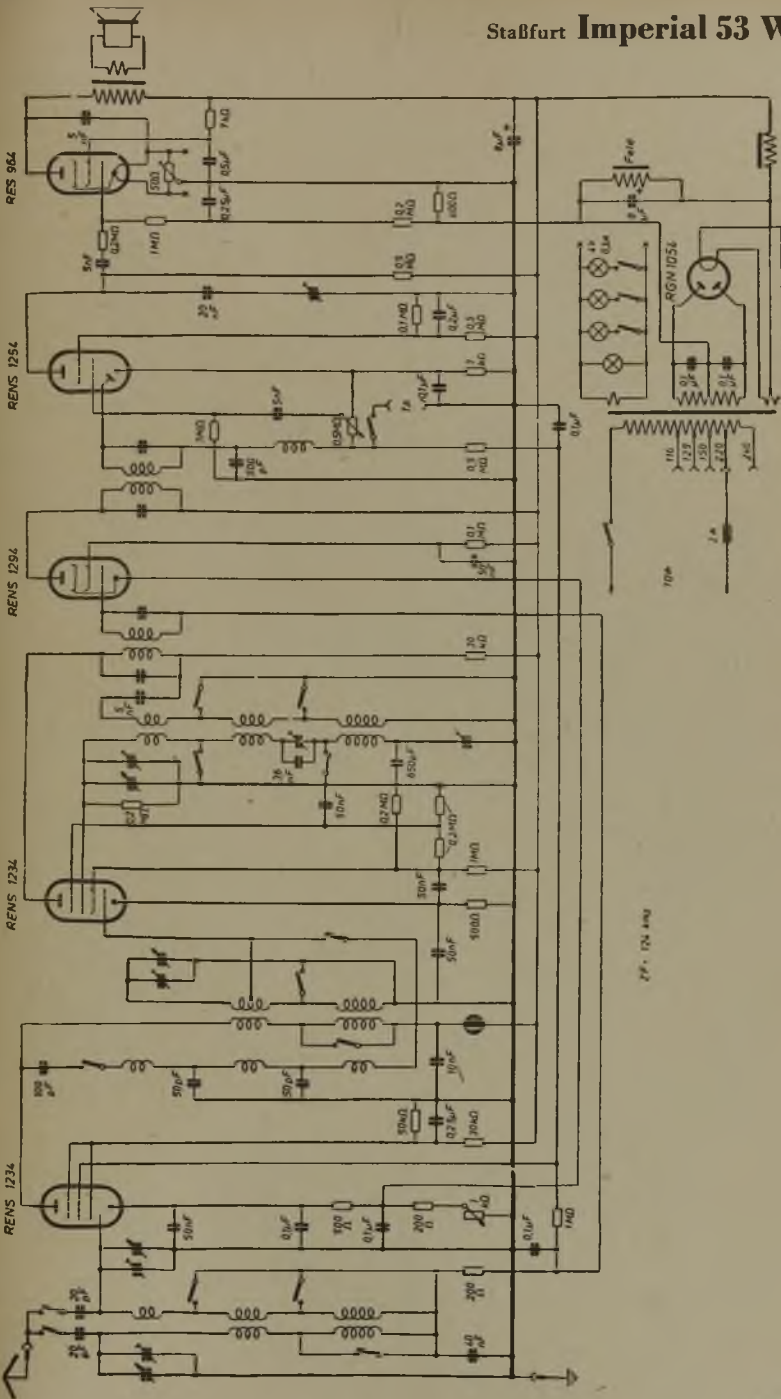

Staßfurt Imperial 53 W (mit Oktode)

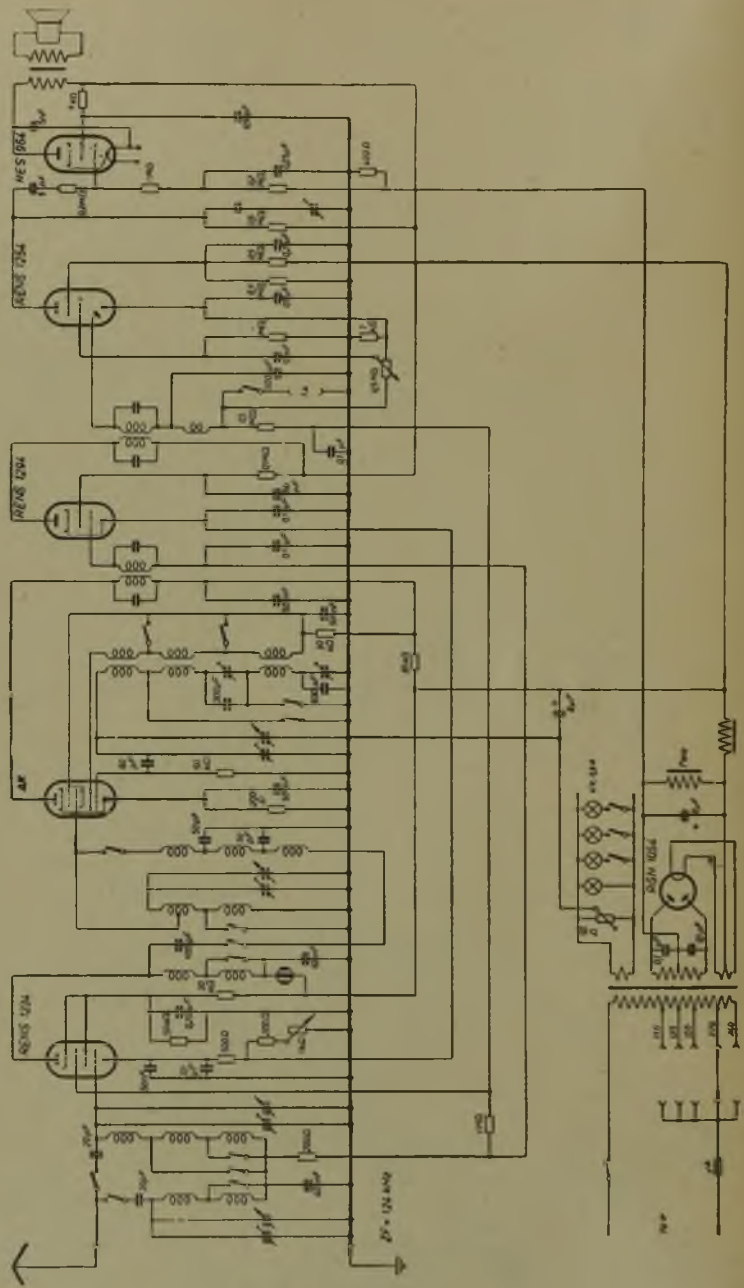

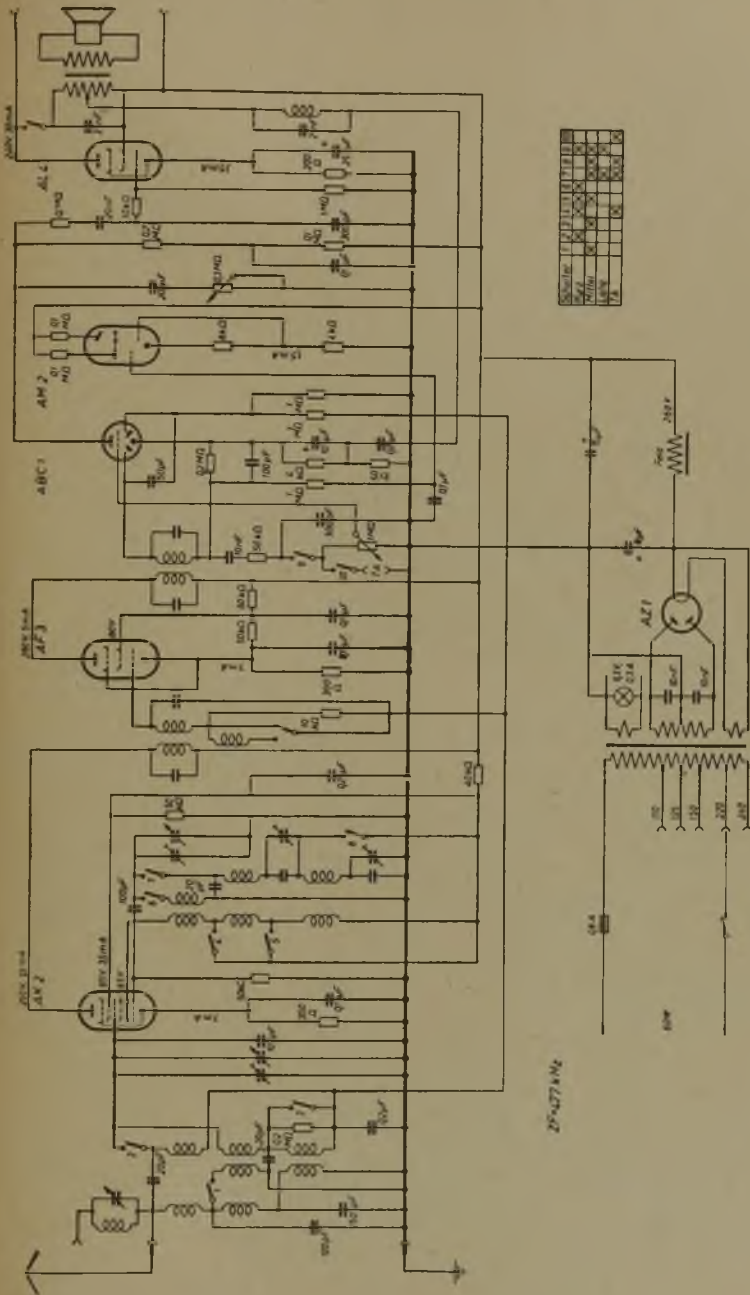

Stufe	1	2	3	4	5	6	7	8
Wider.	250k	100k	100k	100k	100k	100k	100k	100k
Werte	100p	100p	100p	100p	100p	100p	100p	100p
W	0	0	0	0	0	0	0	0

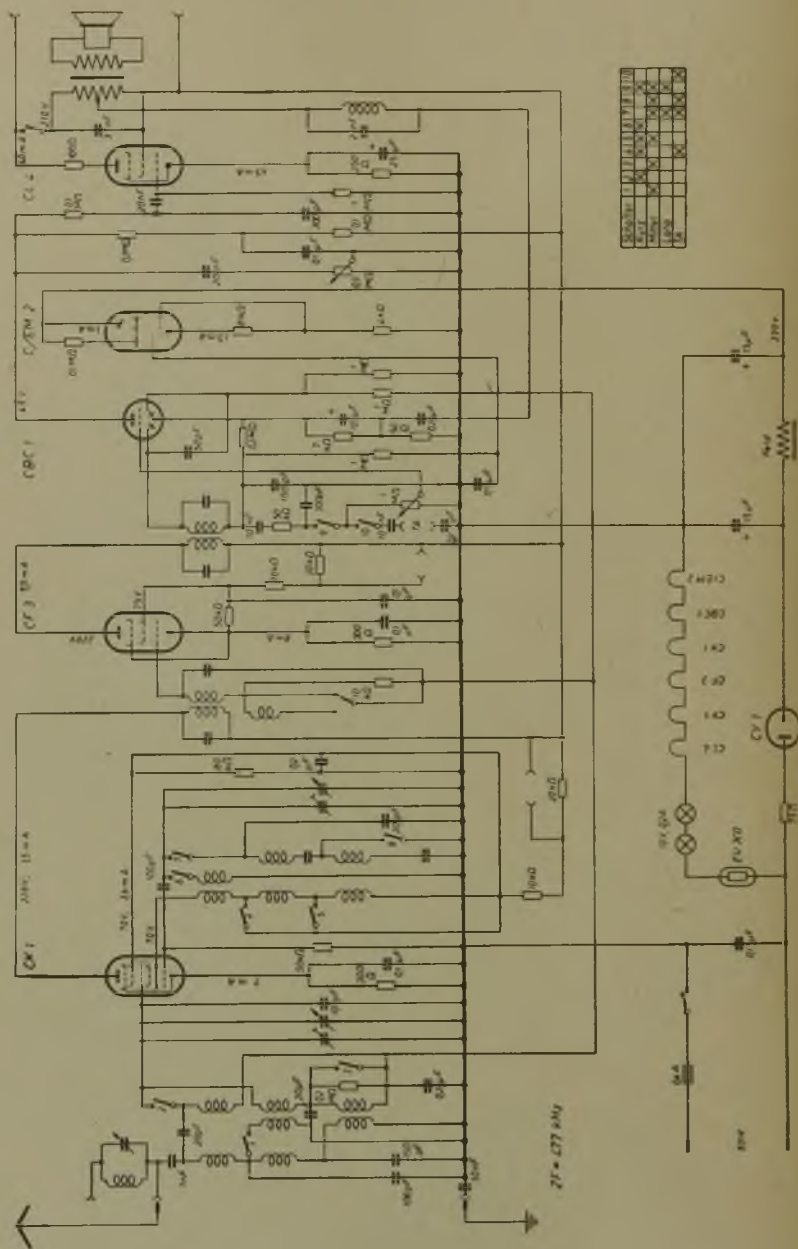

1	2	3	4	5	6	7	8	9	10	11	12	13	14	15	16	17	18	19	20
1	1	1	1	1	1	1	1	1	1	1	1	1	1	1	1	1	1	1	1
2	1	1	1	1	1	1	1	1	1	1	1	1	1	1	1	1	1	1	1
3	1	1	1	1	1	1	1	1	1	1	1	1	1	1	1	1	1	1	1
4	1	1	1	1	1	1	1	1	1	1	1	1	1	1	1	1	1	1	1
5	1	1	1	1	1	1	1	1	1	1	1	1	1	1	1	1	1	1	1
6	1	1	1	1	1	1	1	1	1	1	1	1	1	1	1	1	1	1	1
7	1	1	1	1	1	1	1	1	1	1	1	1	1	1	1	1	1	1	1
8	1	1	1	1	1	1	1	1	1	1	1	1	1	1	1	1	1	1	1
9	1	1	1	1	1	1	1	1	1	1	1	1	1	1	1	1	1	1	1
10	1	1	1	1	1	1	1	1	1	1	1	1	1	1	1	1	1	1	1

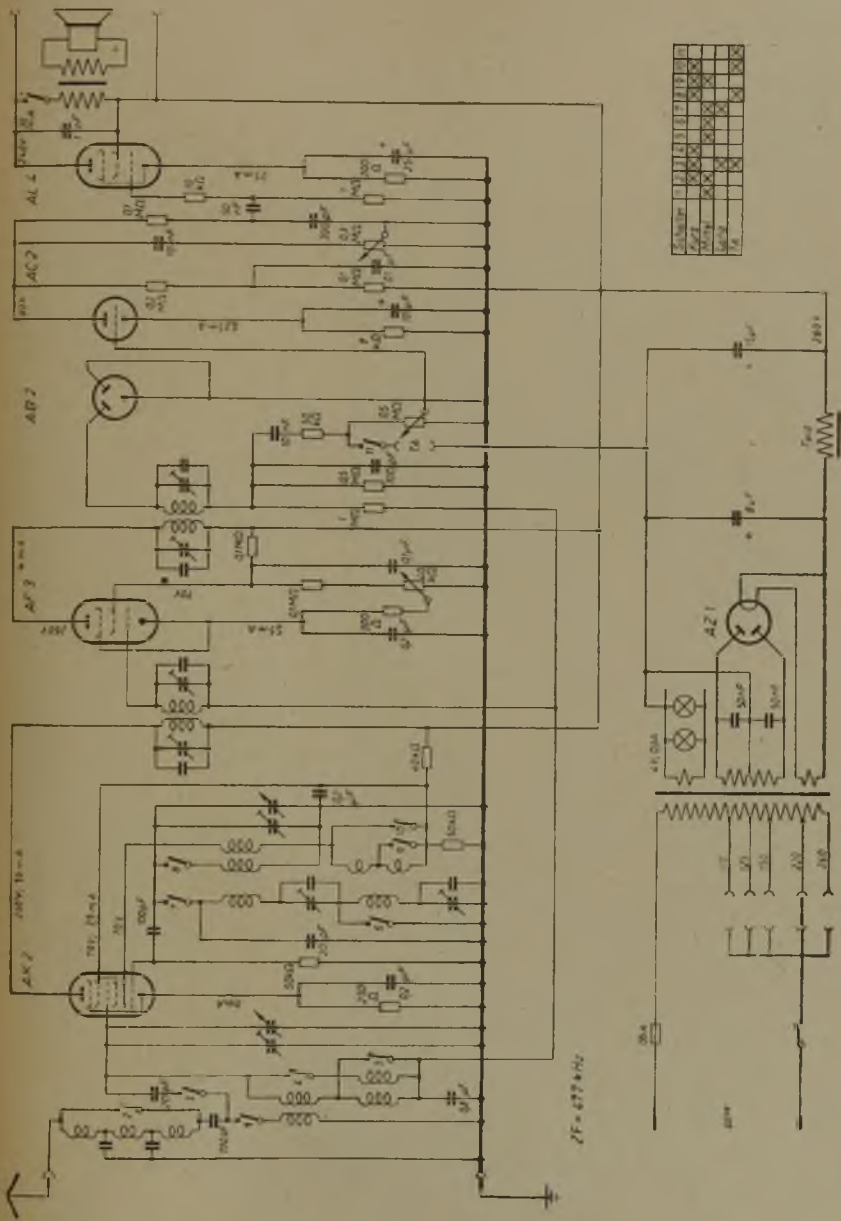

1	2	3	4	5	6	7	8	9	10
11	12	13	14	15	16	17	18	19	20
21	22	23	24	25	26	27	28	29	30
31	32	33	34	35	36	37	38	39	40
41	42	43	44	45	46	47	48	49	50

Staffurt Imperial 48 GW

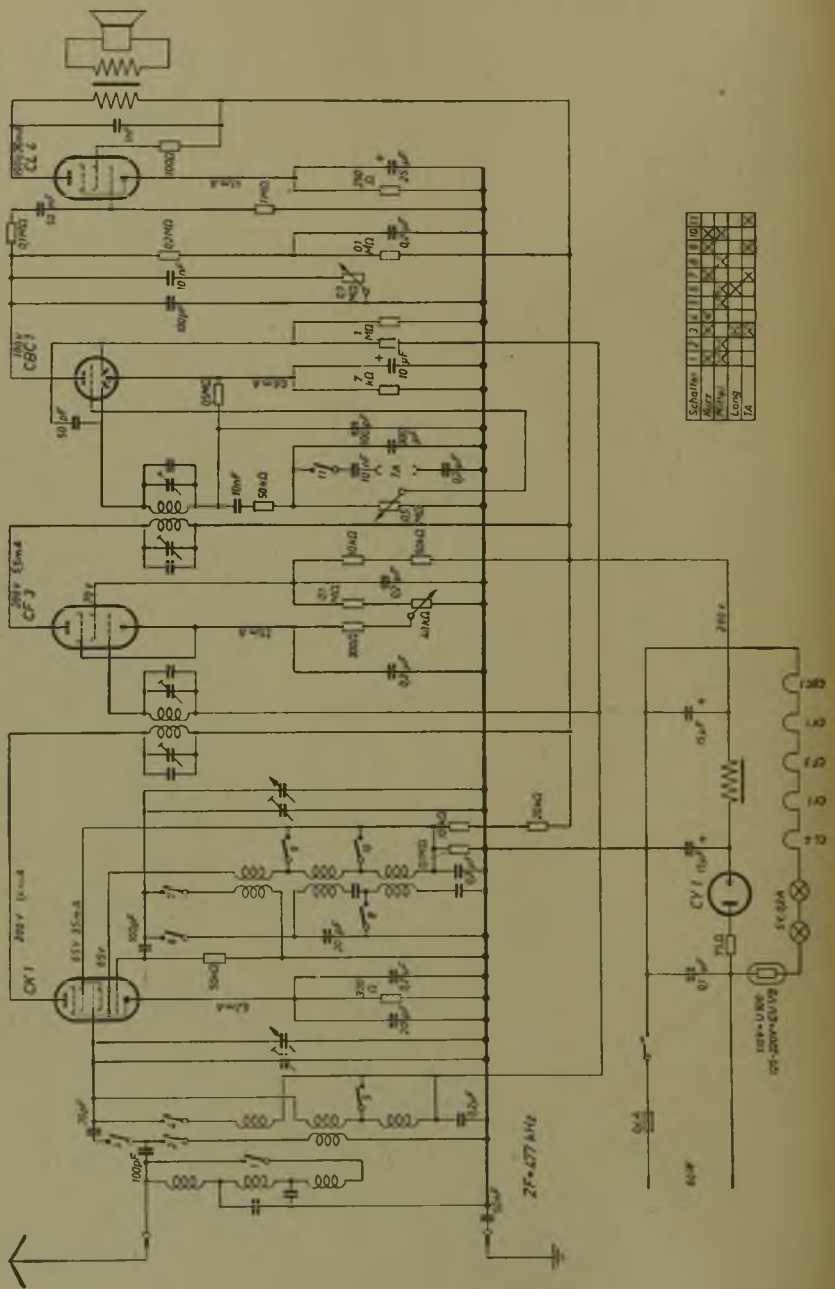

Schaltplan	1	2	3	4	5	6	7	8	9	10	11
Netz											
6BE6											
6X4											
6X4											
5Y5											
500k											
100k											
100V											
250V											

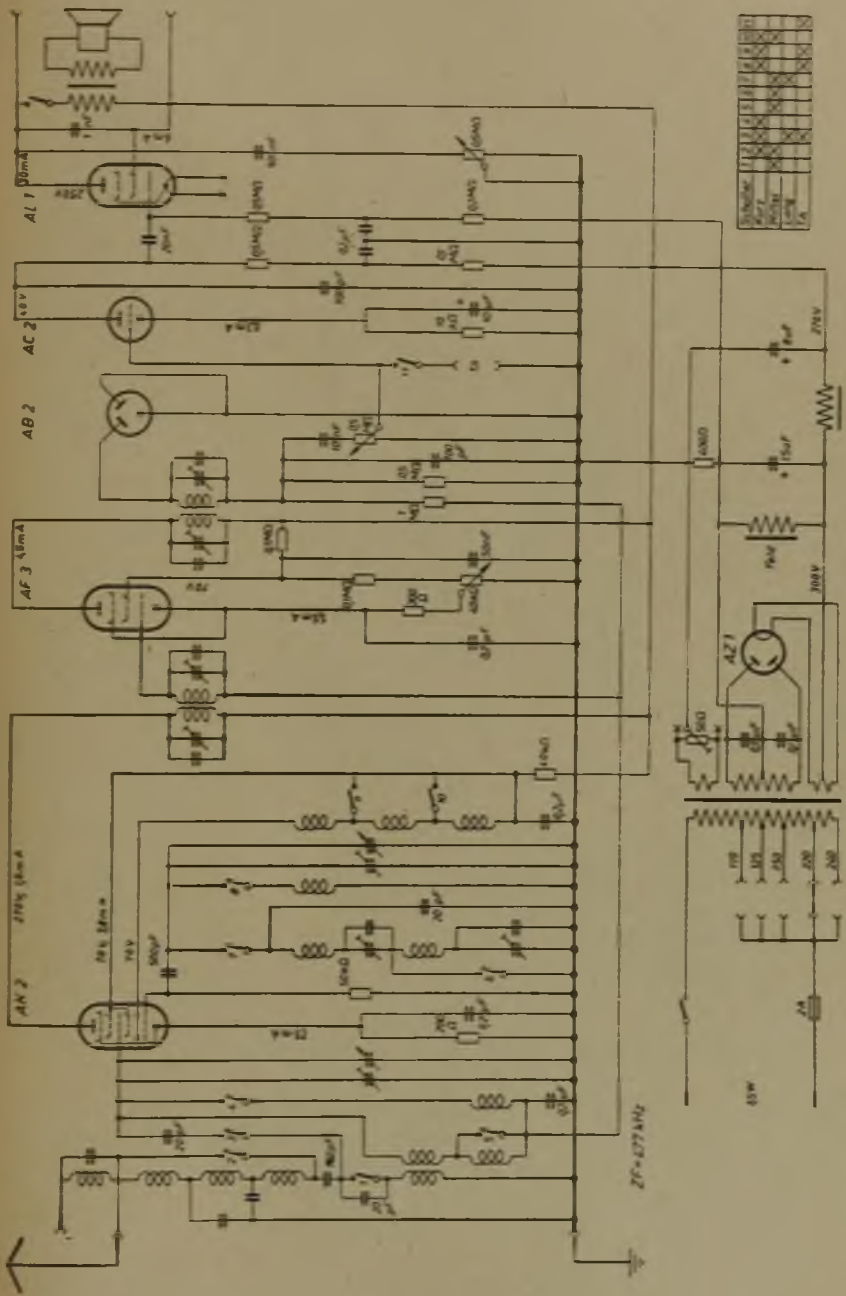

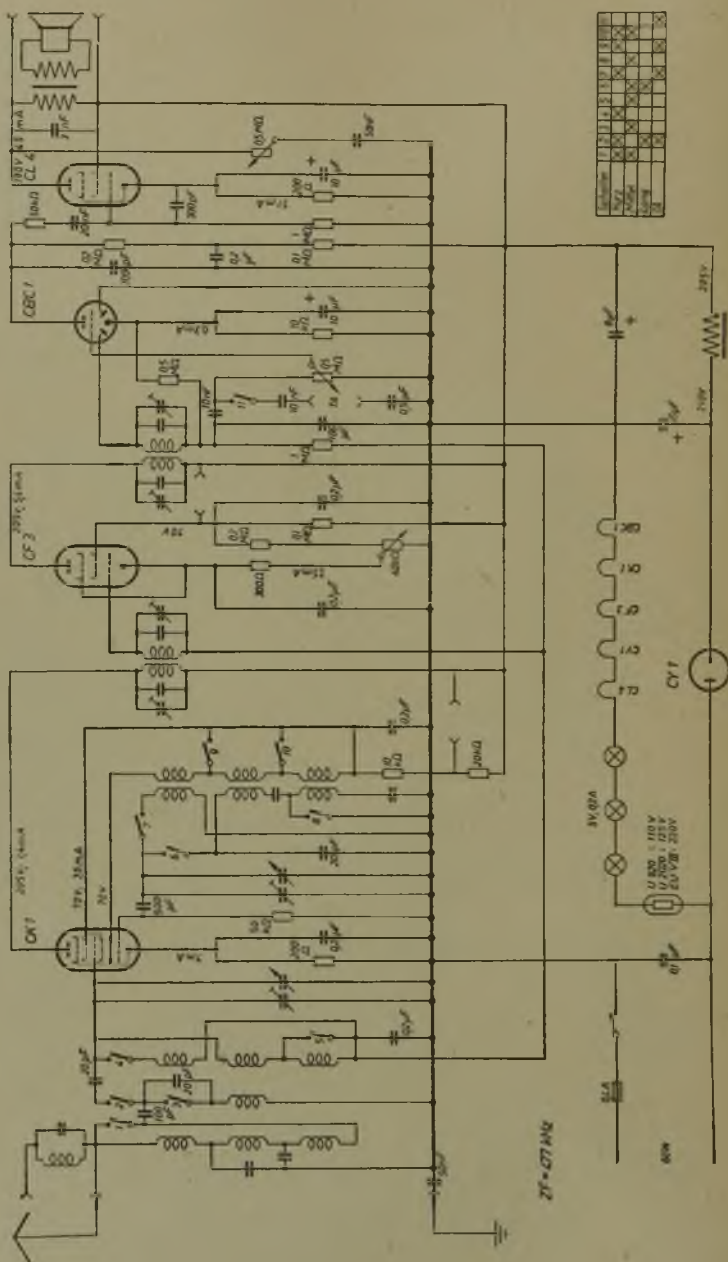

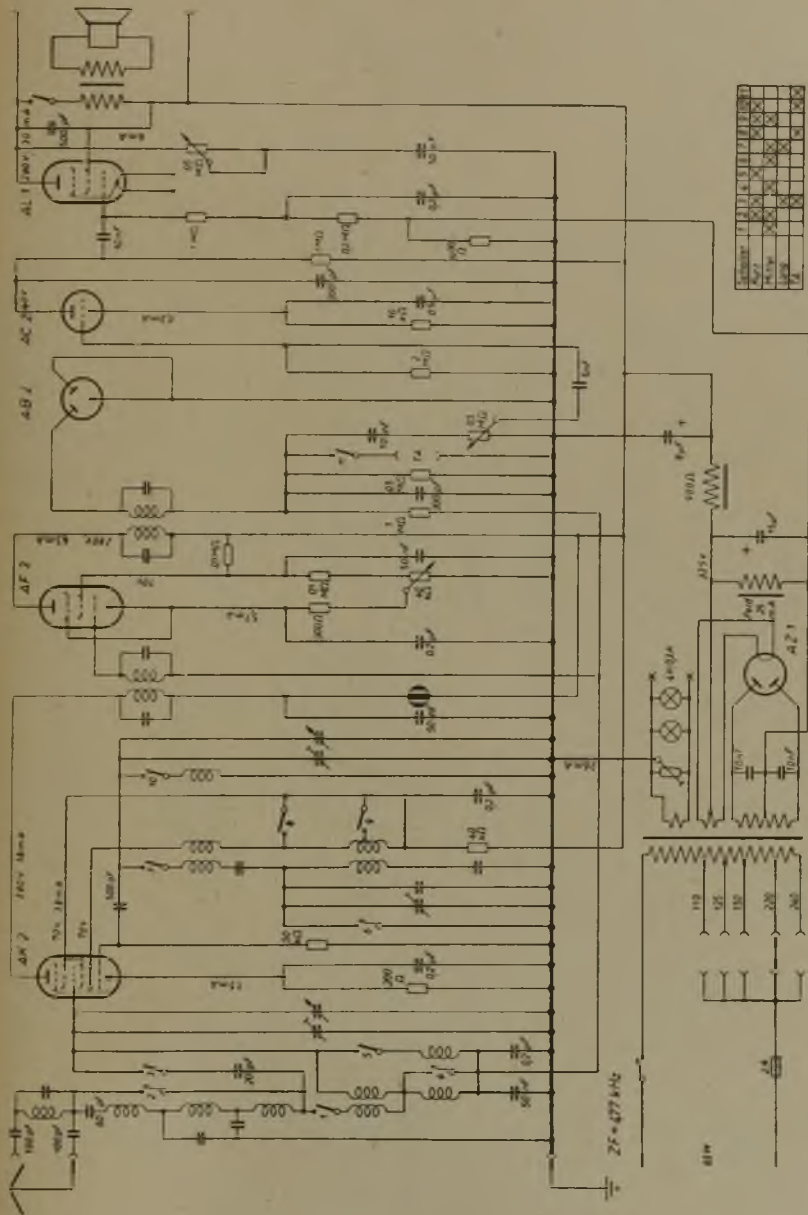

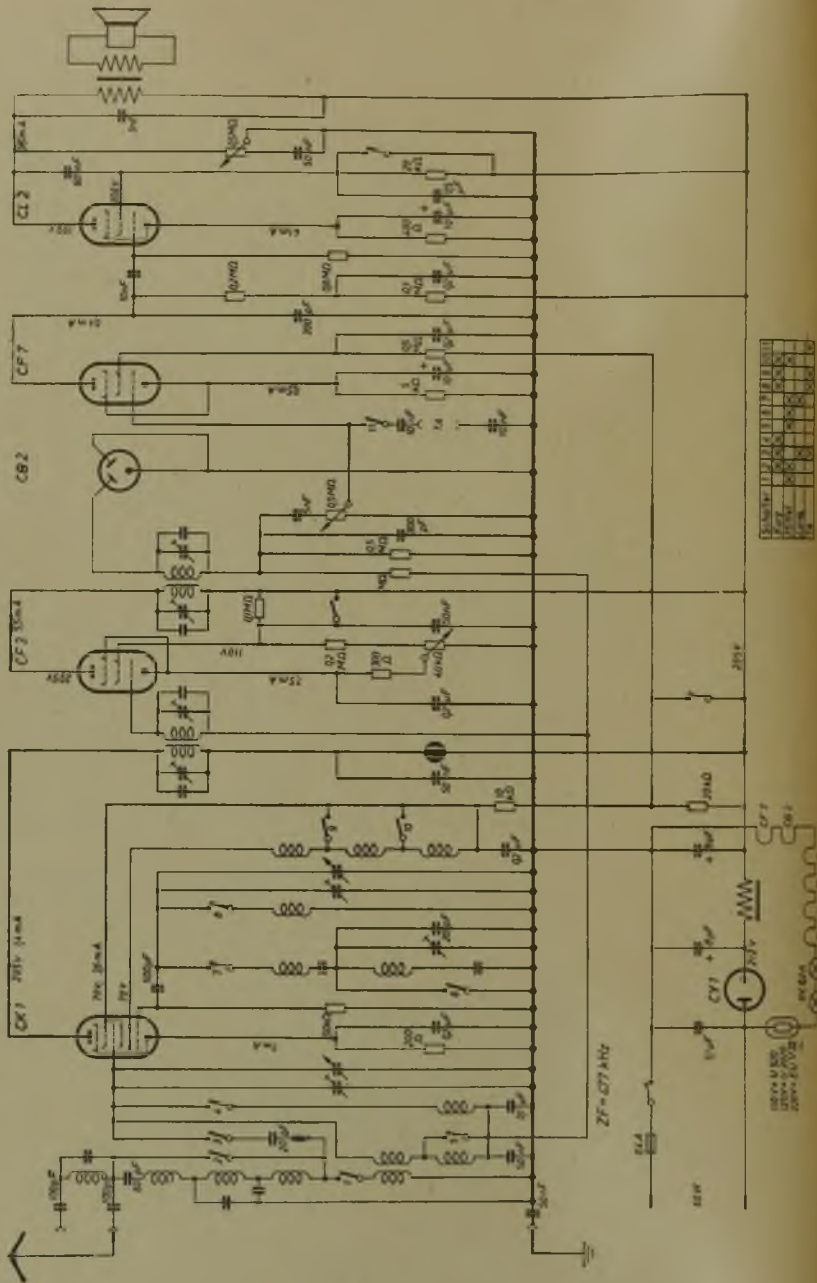

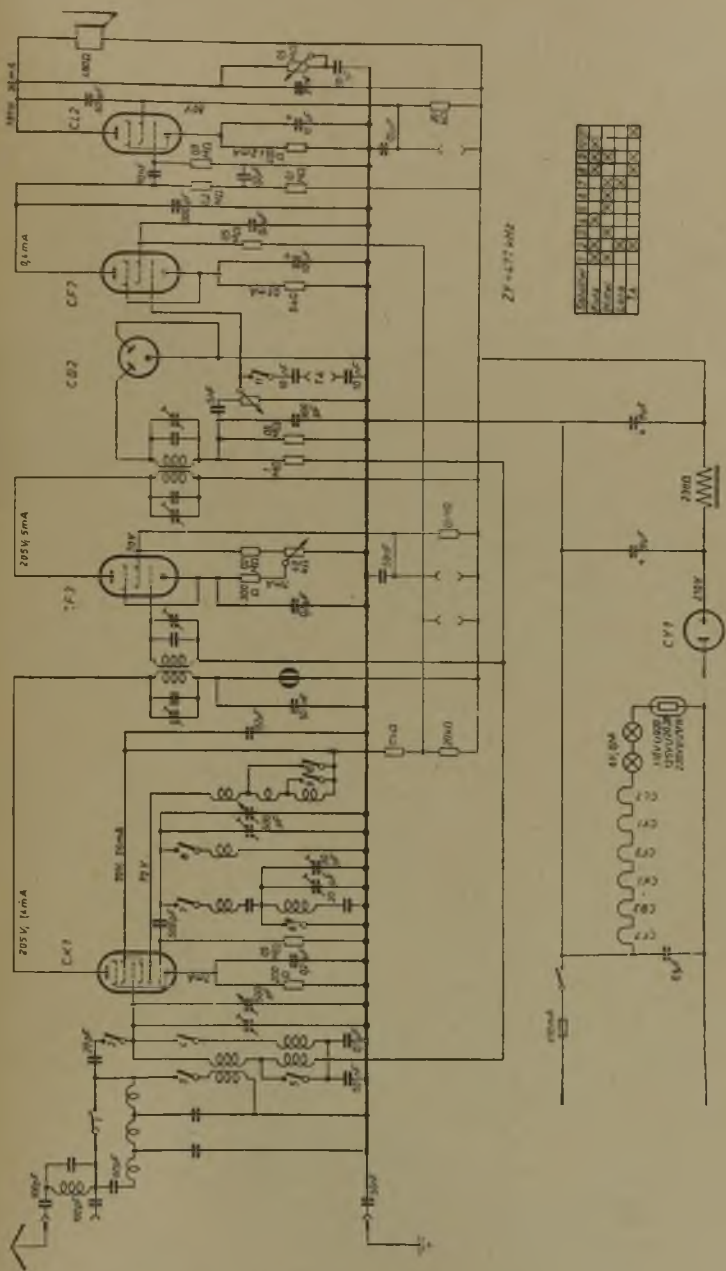

Stufe	1	2	3	4	5	6	7	8	9	10	11	12	13	14	15	16	17	18	19	20
1																				
2																				
3																				
4																				
5																				
6																				
7																				
8																				
9																				
10																				
11																				
12																				
13																				
14																				
15																				
16																				
17																				
18																				
19																				
20																				

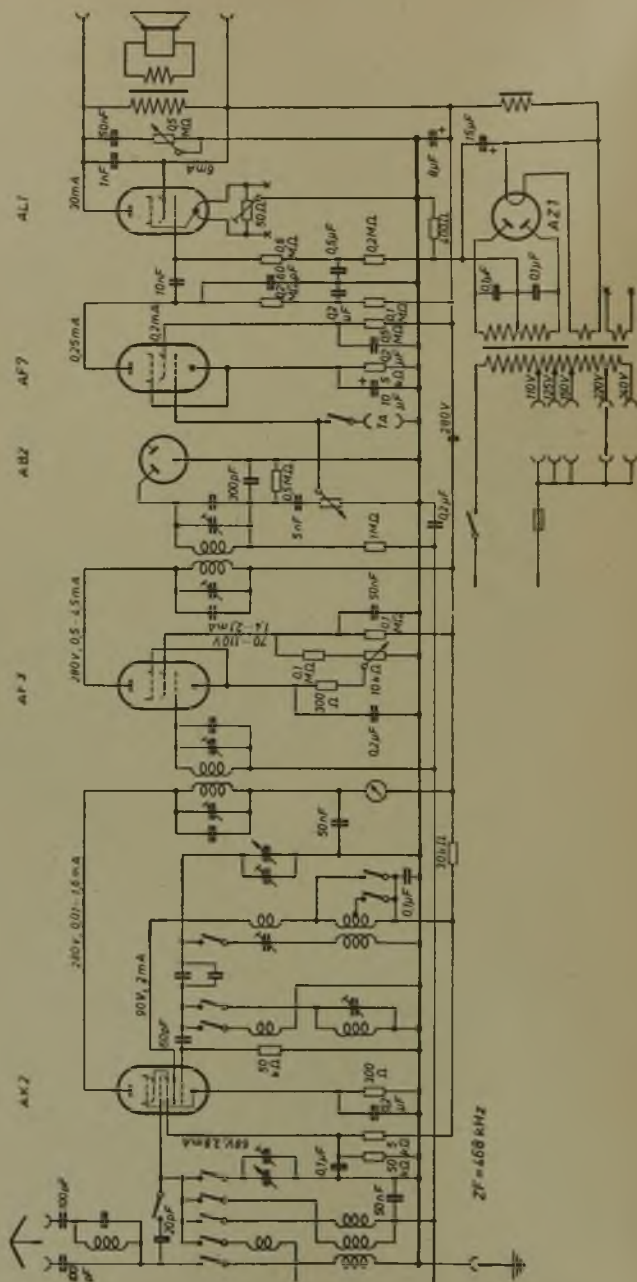

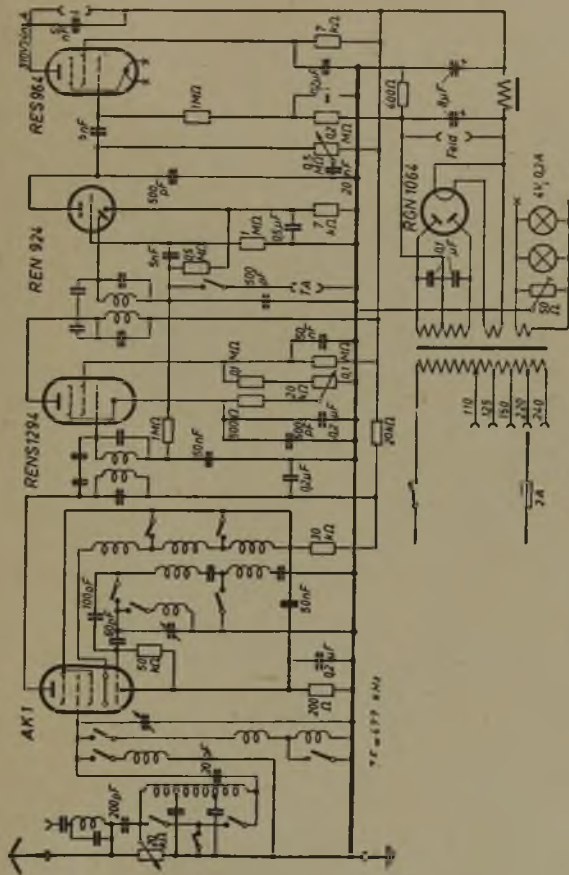

StaBfurt Imperial 44 G (220 V)

BL 2

RENS 1854

RENS 1894

RENS 1832

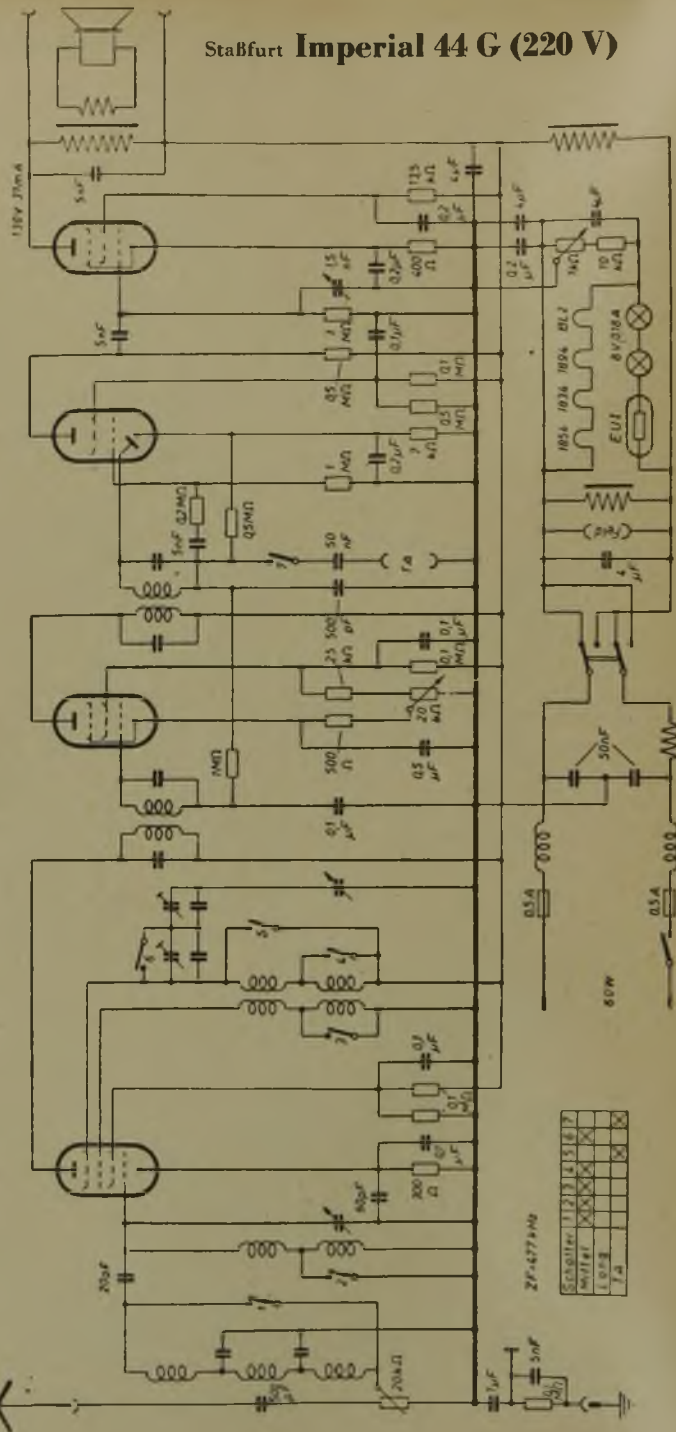

ZF-4774-M4

Schalter	112	3	4	5	6	7
Wolfram	X	X	X	X	X	X
LED						
L.A.						

Staßfurt Imperial 44 G (110 V)

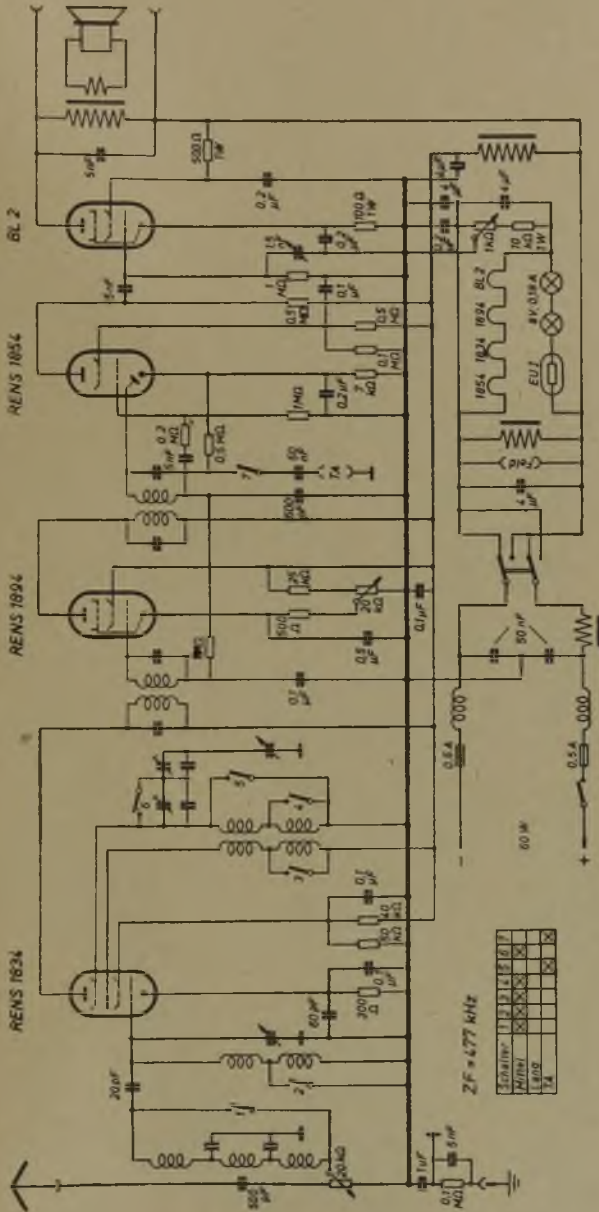

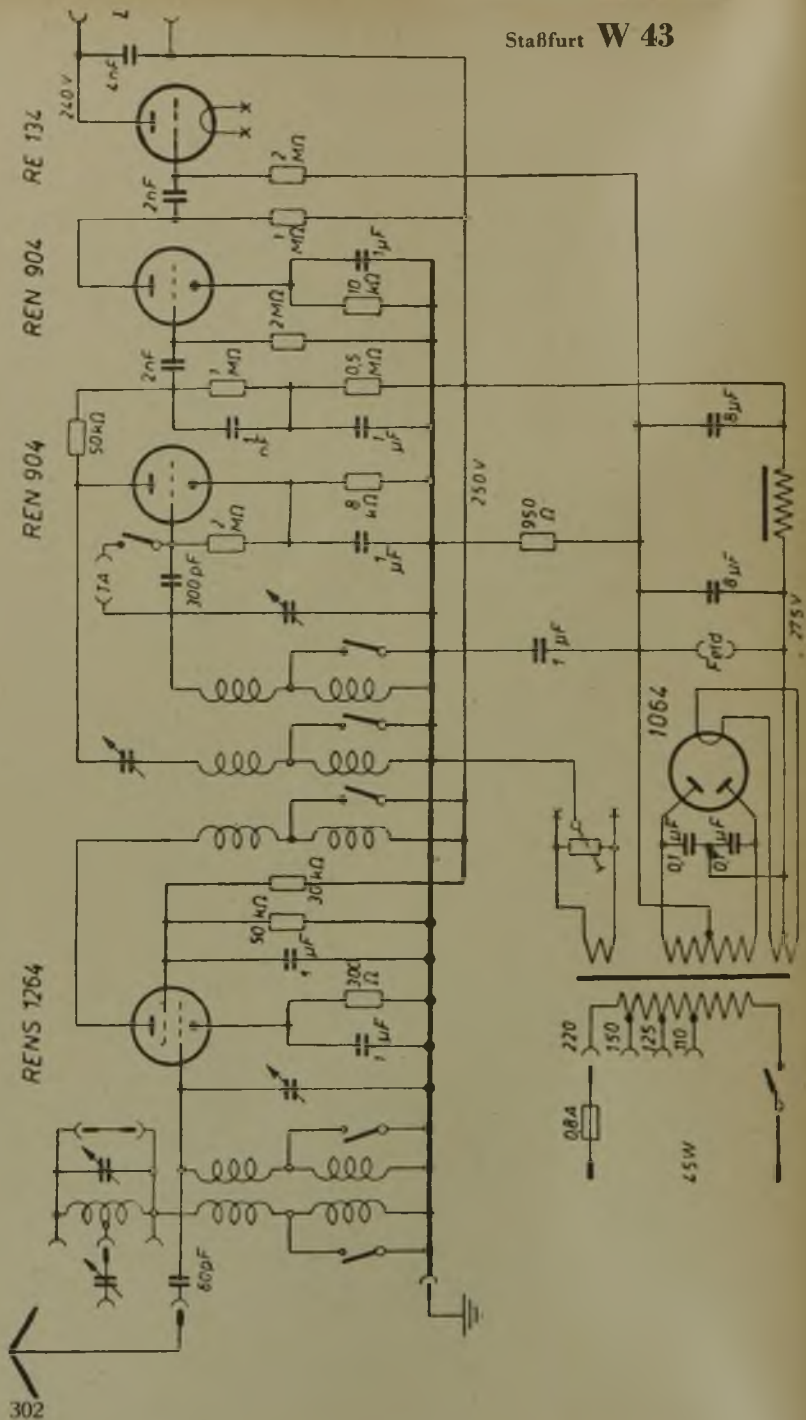

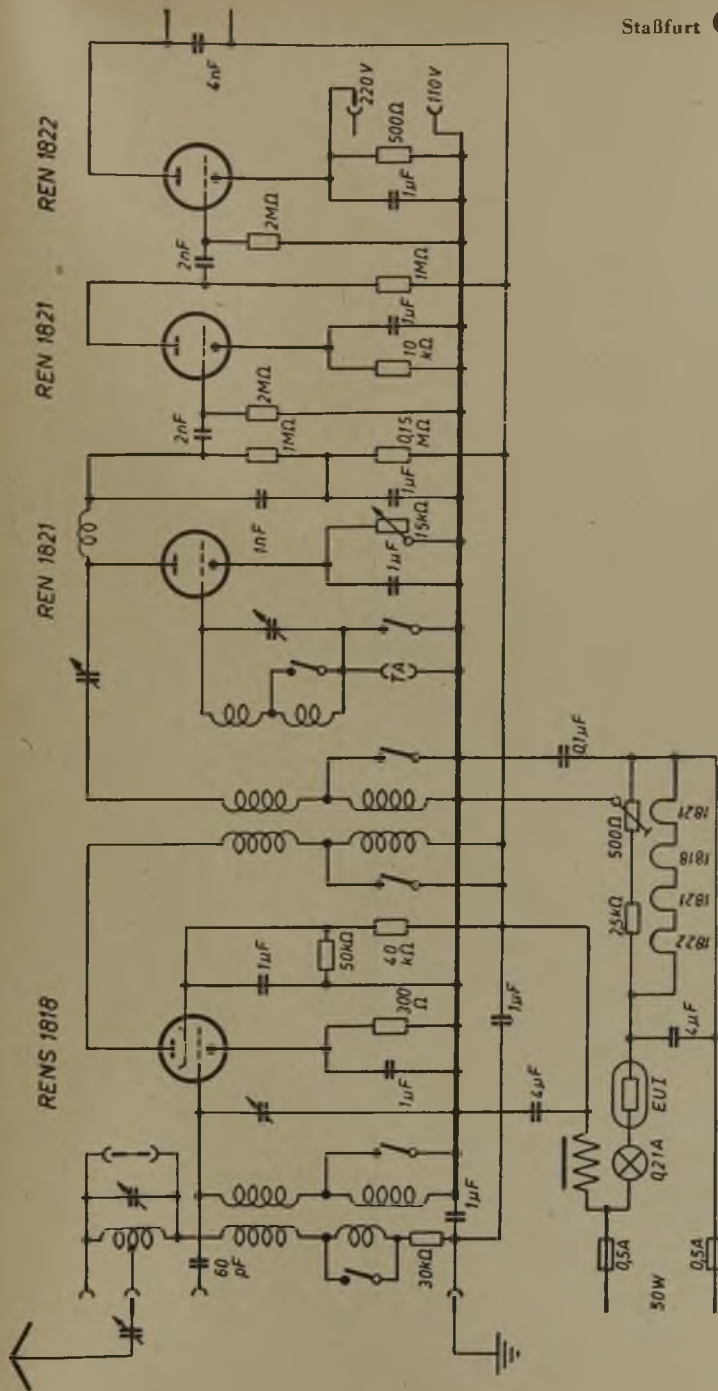

Staffurt W 42 und W 41

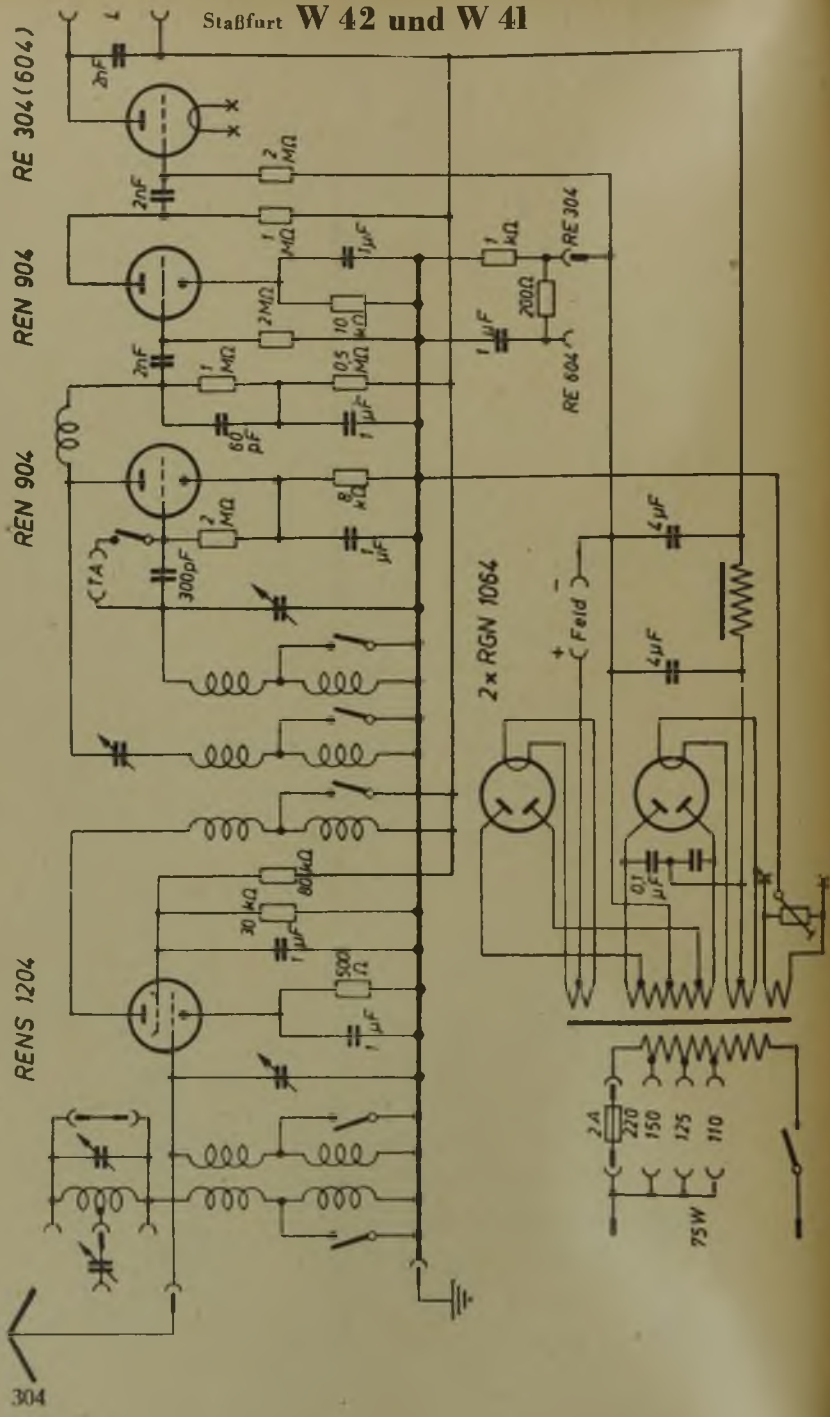

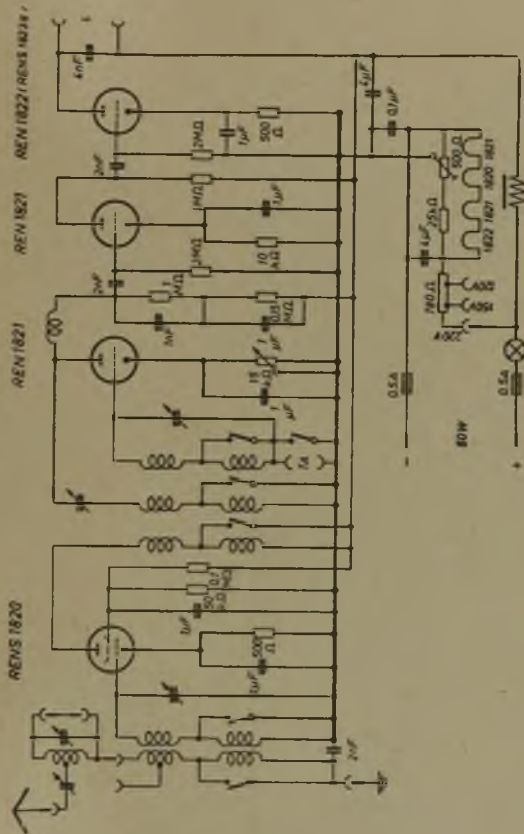

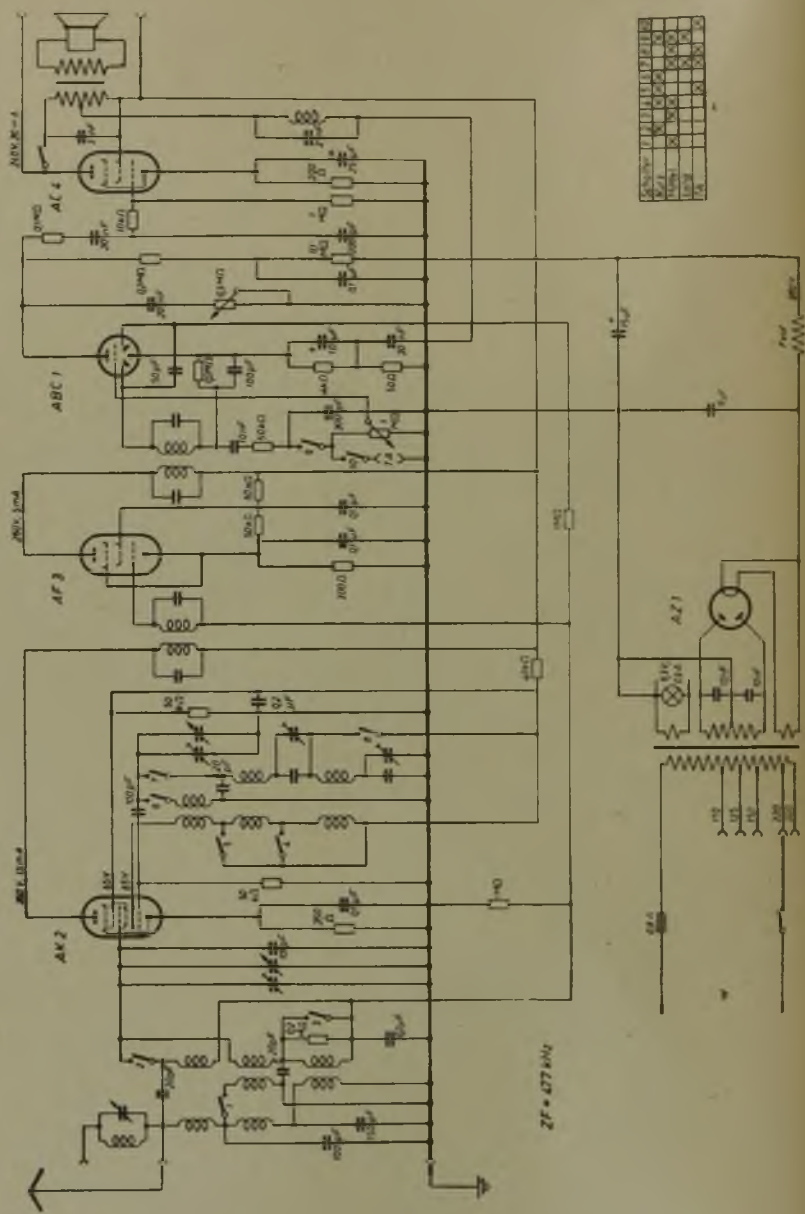

6X4	6X5	6X6	6X7	6X8	6X9	6X10	6X11	6X12	6X13	6X14	6X15	6X16	6X17	6X18	6X19	6X20	6X21	6X22	6X23	6X24	6X25	6X26	6X27	6X28	6X29	6X30	6X31	6X32	6X33	6X34	6X35	6X36	6X37	6X38	6X39	6X40	6X41	6X42	6X43	6X44	6X45	6X46	6X47	6X48	6X49	6X50
-----	-----	-----	-----	-----	-----	------	------	------	------	------	------	------	------	------	------	------	------	------	------	------	------	------	------	------	------	------	------	------	------	------	------	------	------	------	------	------	------	------	------	------	------	------	------	------	------	------

Staßfurt Imperial 40 GW und 4 BGW

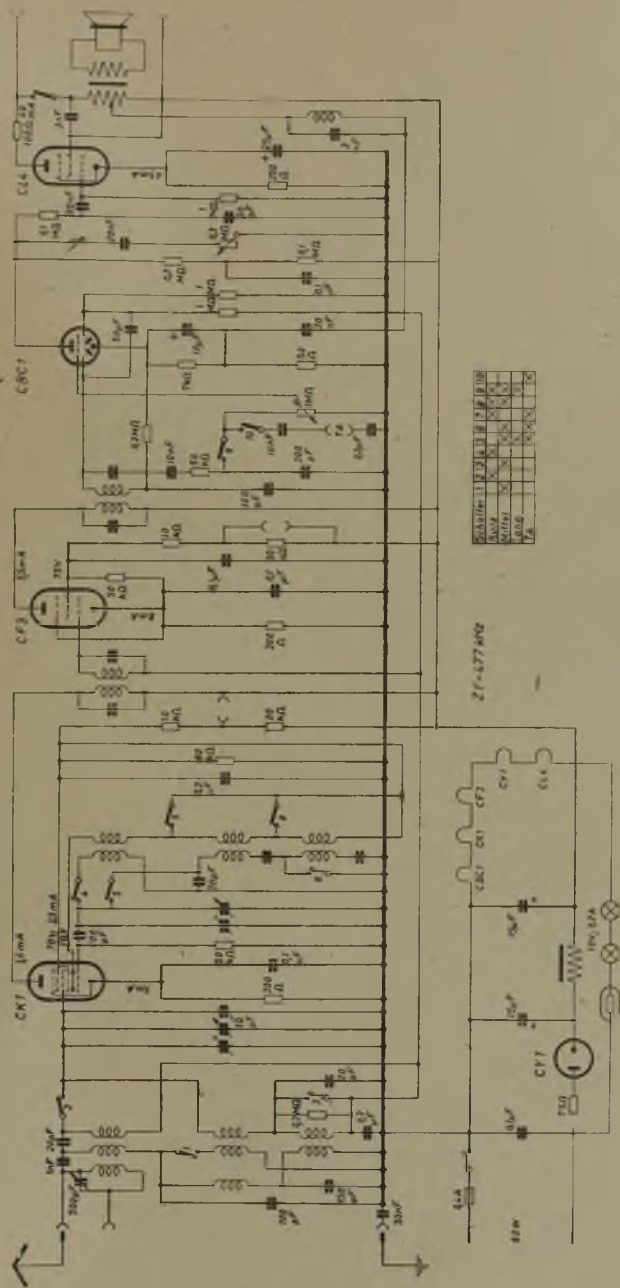

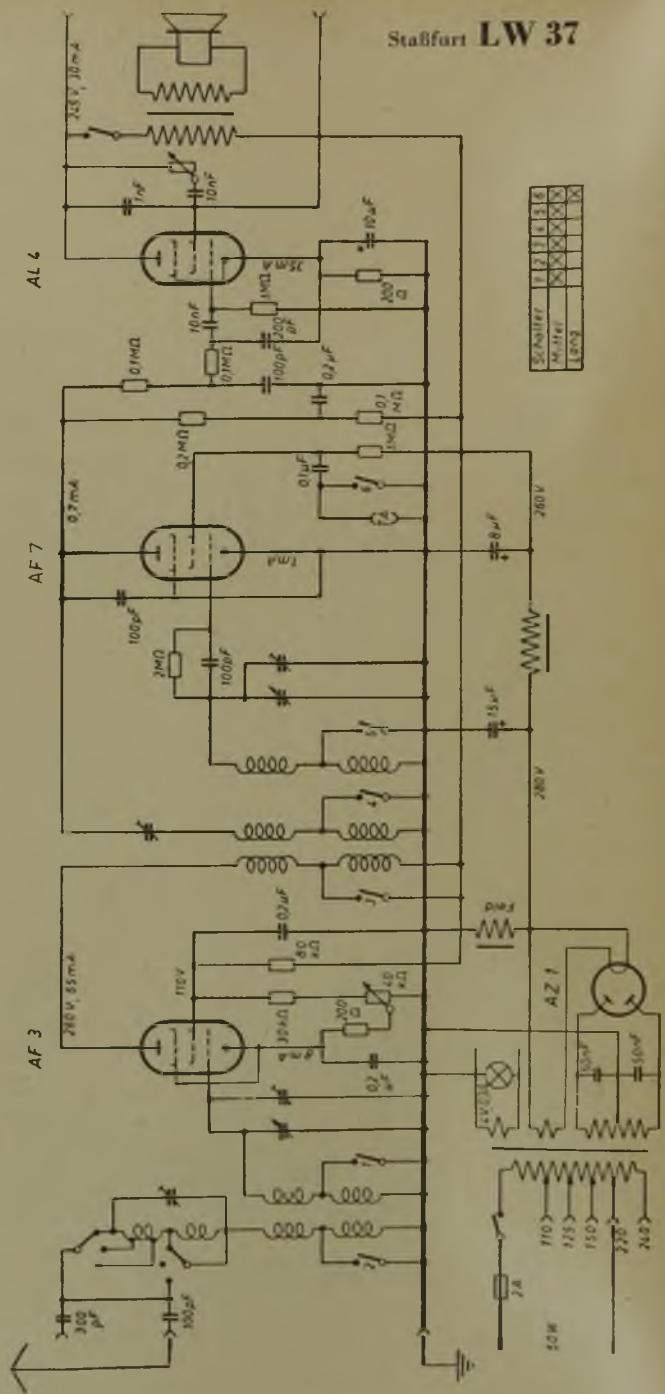

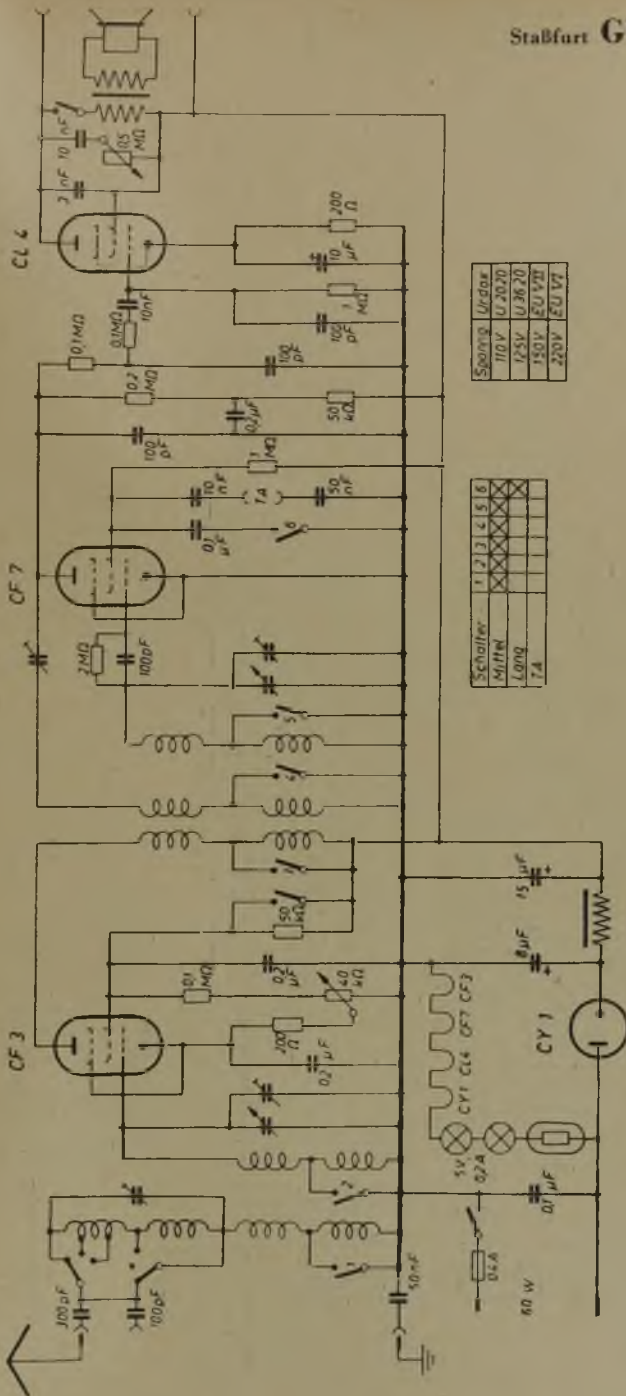

Spannung	Urdax
110V	U 2020
125V	U 26 20
150V	EU V21
220V	EU V7

Schalter	1 2 3 4 5 6					
	Mittl.	×	×	×	×	×
Lang.						
7A						

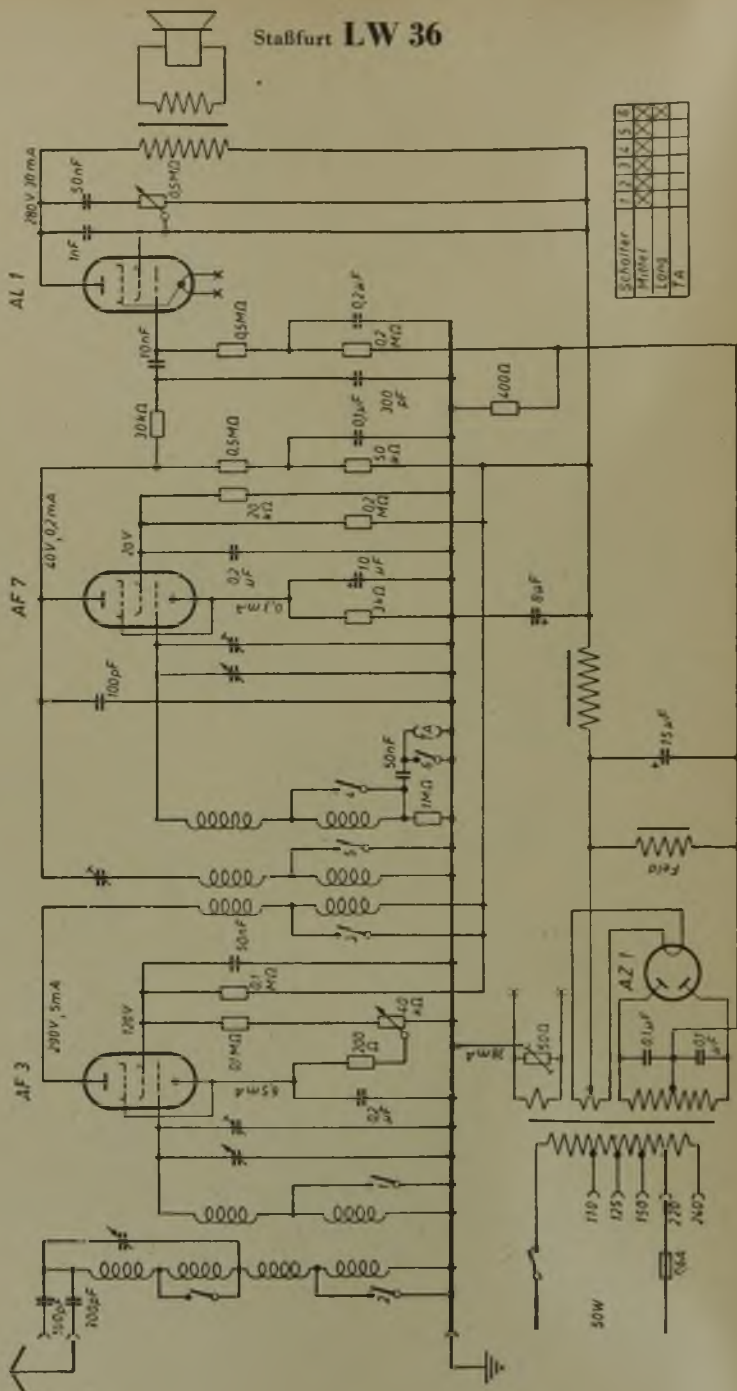

Schalter	1	2	3	4	5	6
Michael	X	X	X	X	X	X
L.009						
YA						

Staßfurt Imperial 35 W

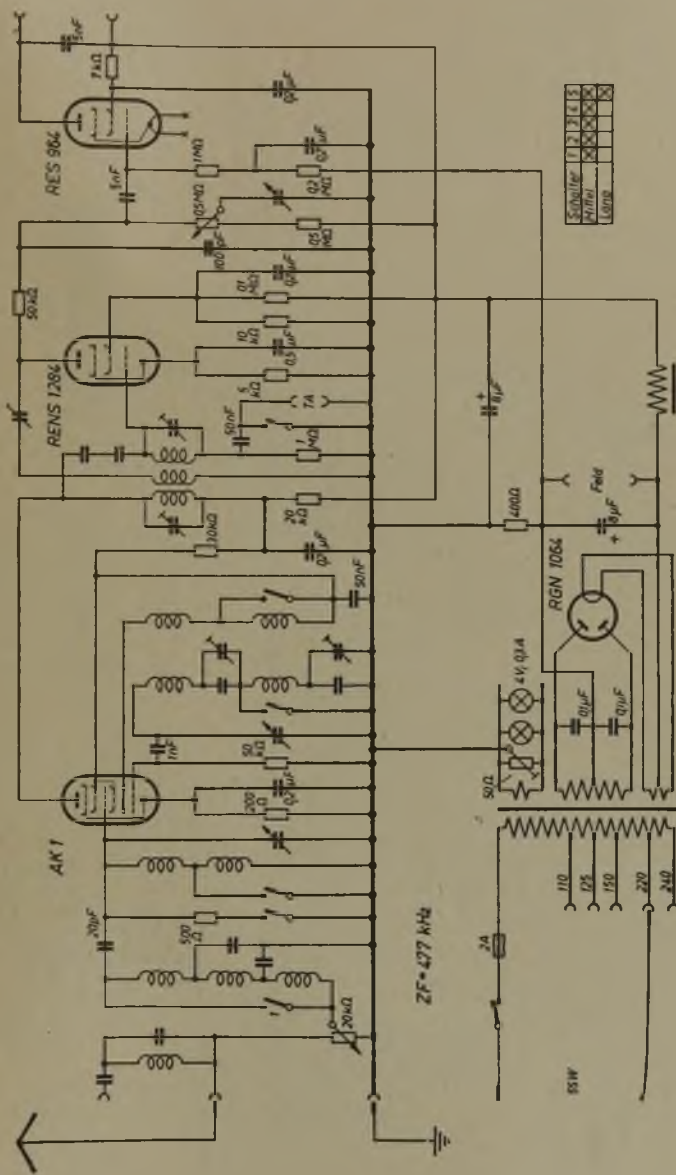

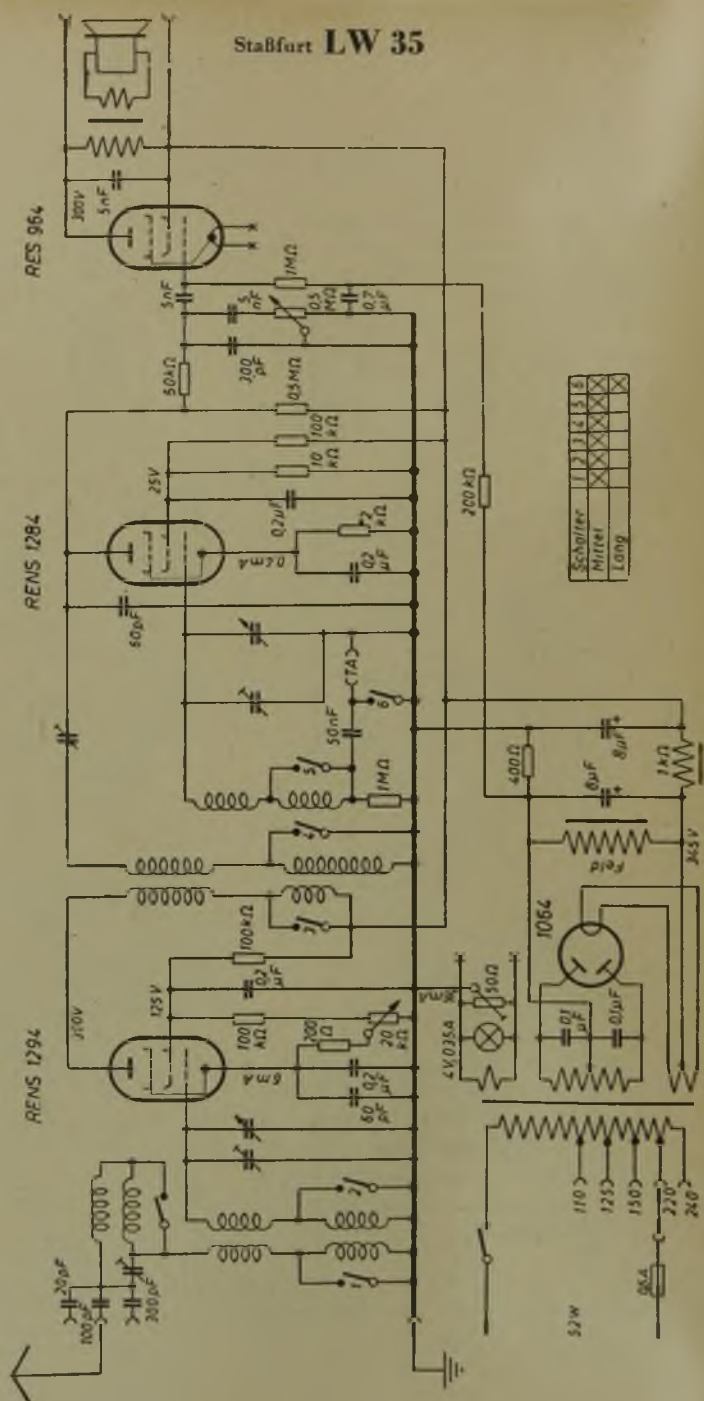

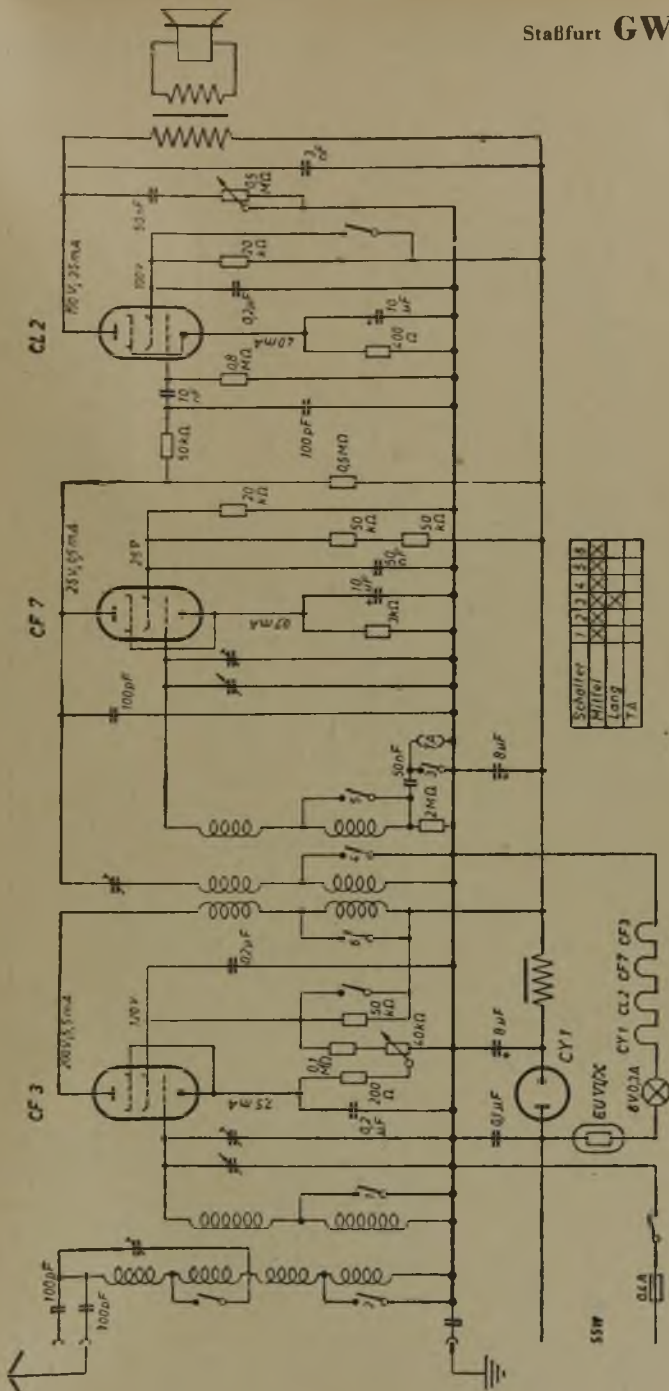

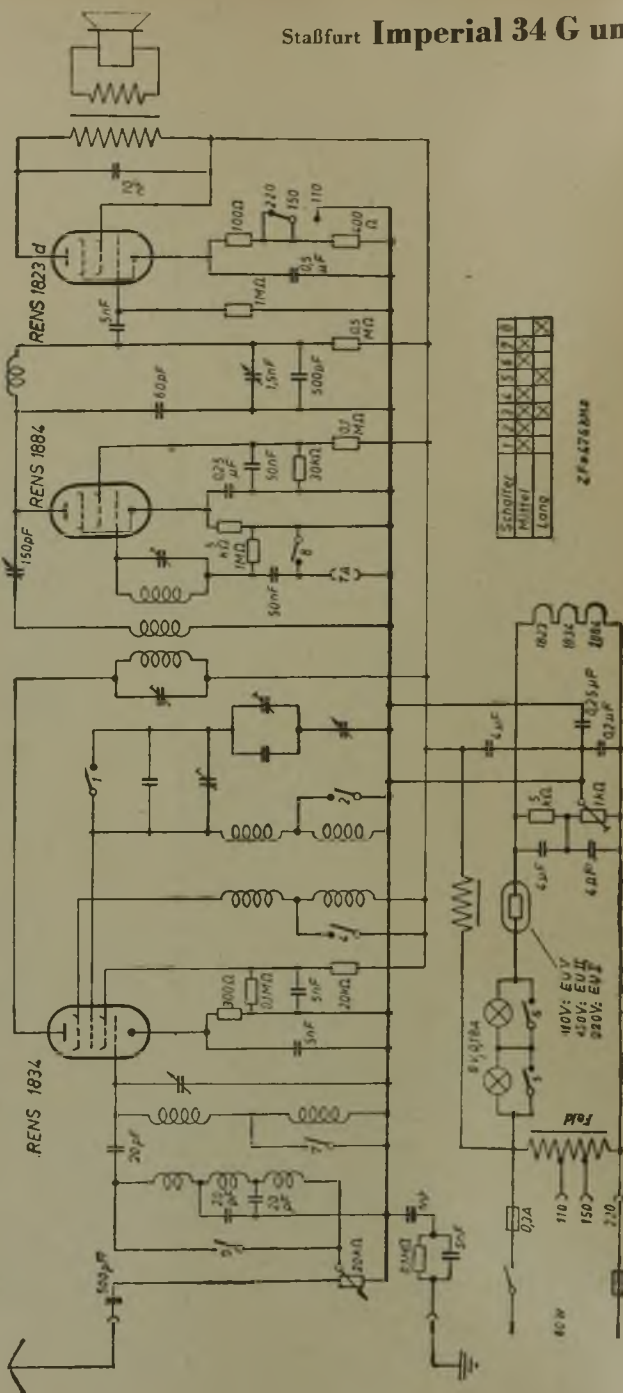

Staufurt	1	2	3	4	5	6	7	8
Mittel	X	X	X	X	X	X	X	X
Long	X	X	X	X	X	X	X	X

ZF = 476 kHz

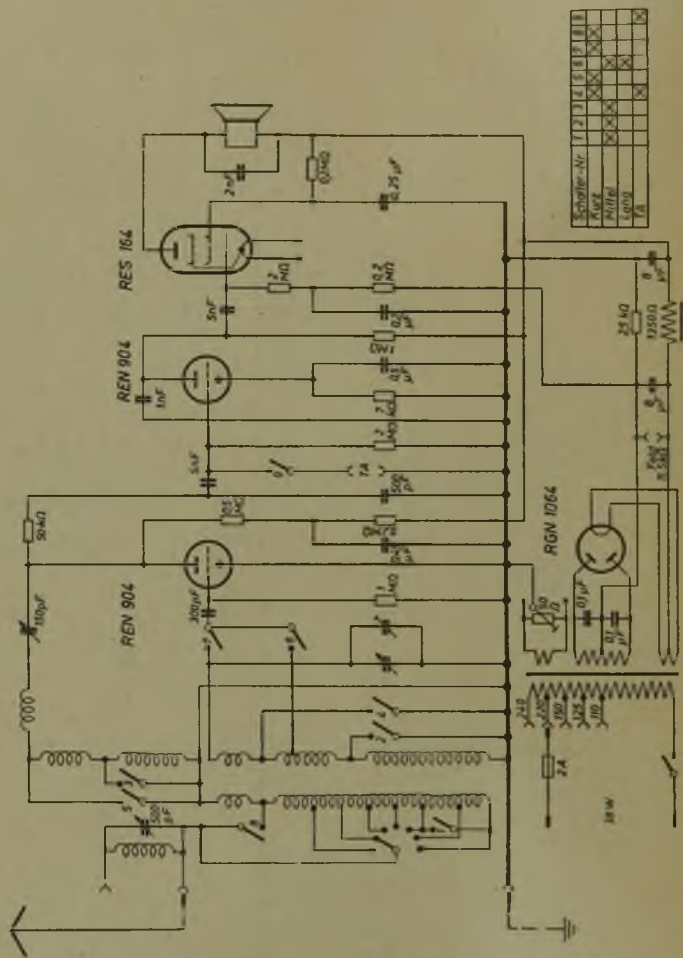

Schalt-Nr.	1	2	3	4	5	6	7	8	9	10
Kopf	X	X	X	X	X	X	X	X	X	X
Mittel	X	X	X	X	X	X	X	X	X	X
Links	X	X	X	X	X	X	X	X	X	X
Rechts	X	X	X	X	X	X	X	X	X	X

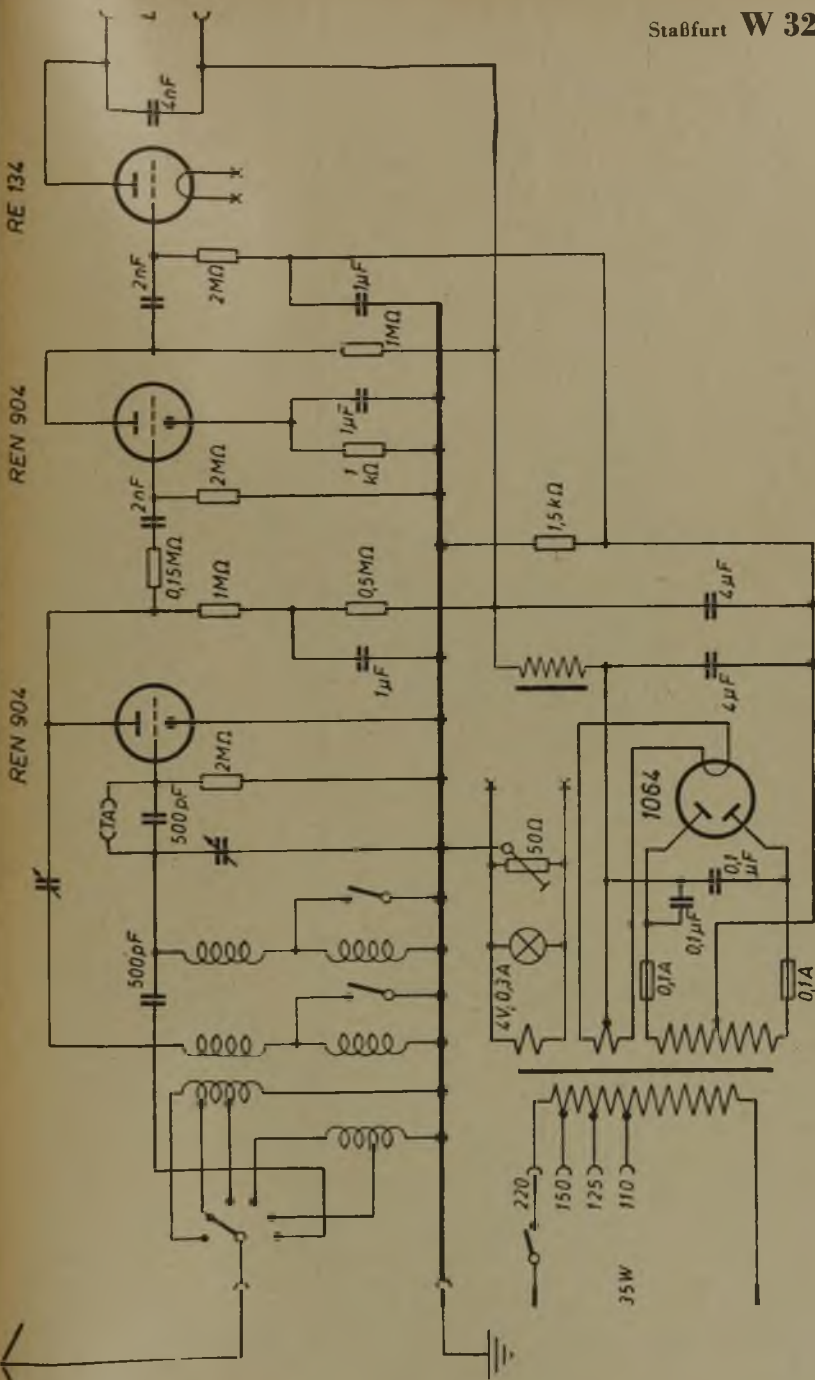

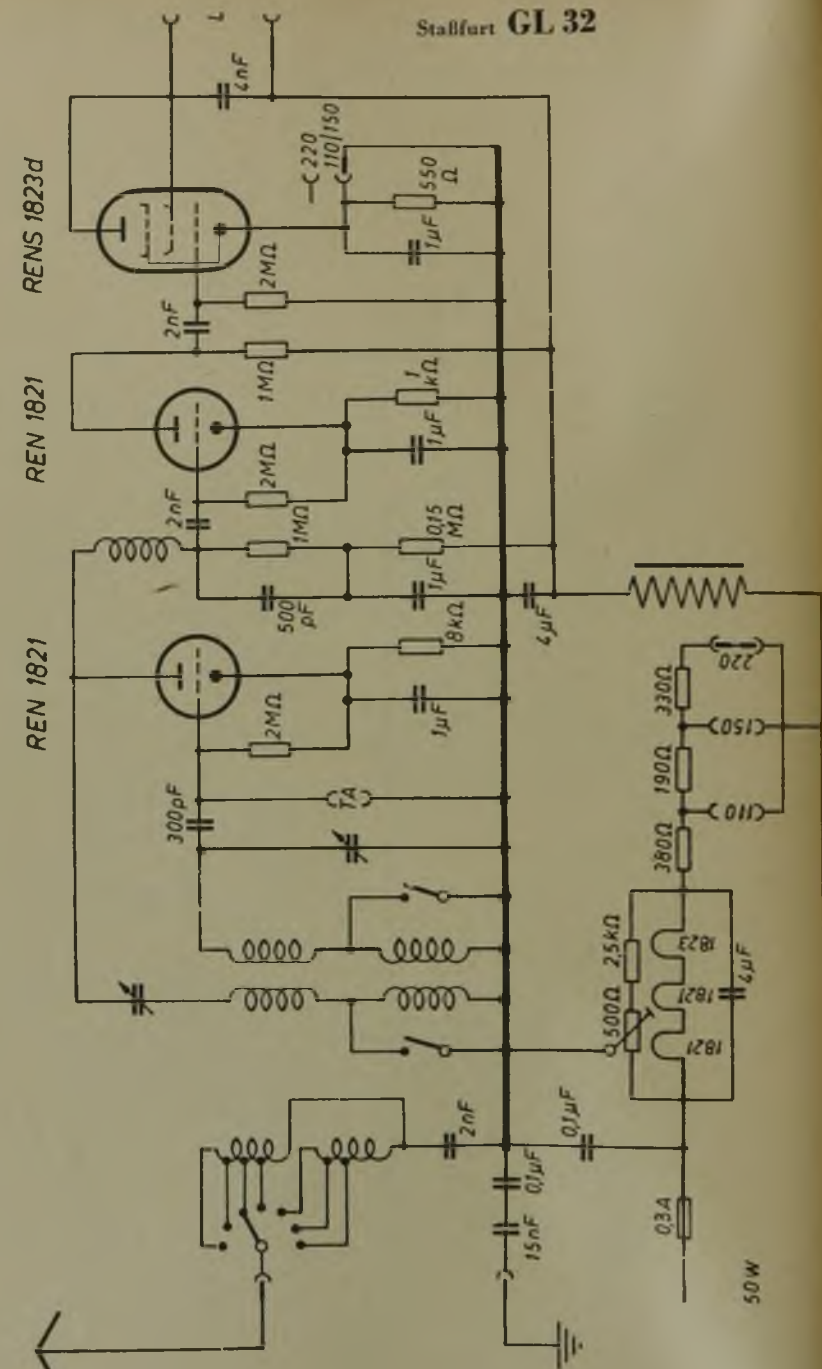

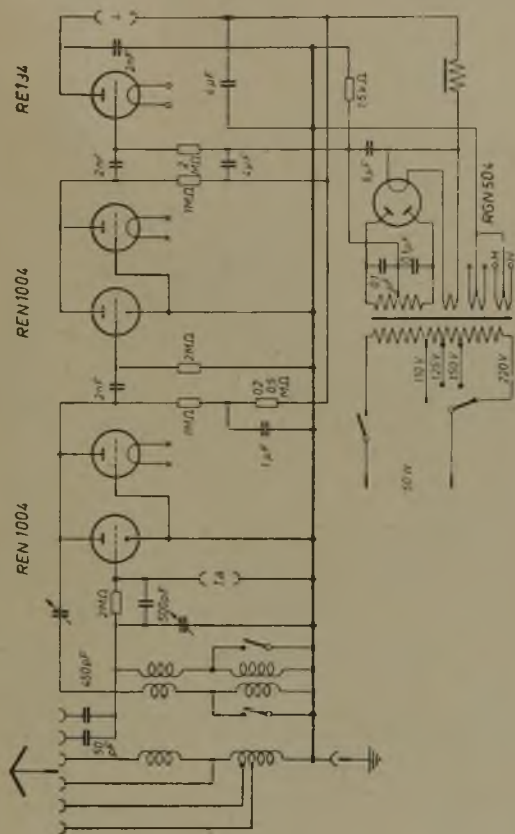

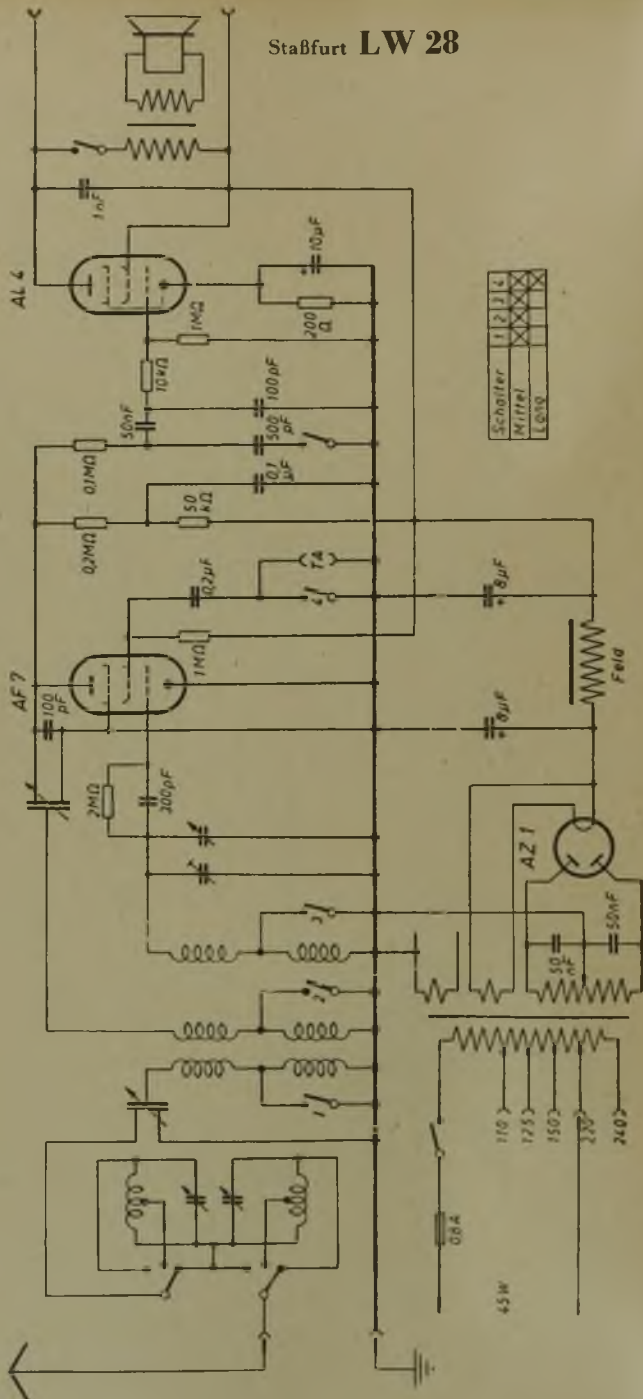

Schalter	1	2	3	4
Mittel	X	X	X	X
LESTO	X	X	X	X

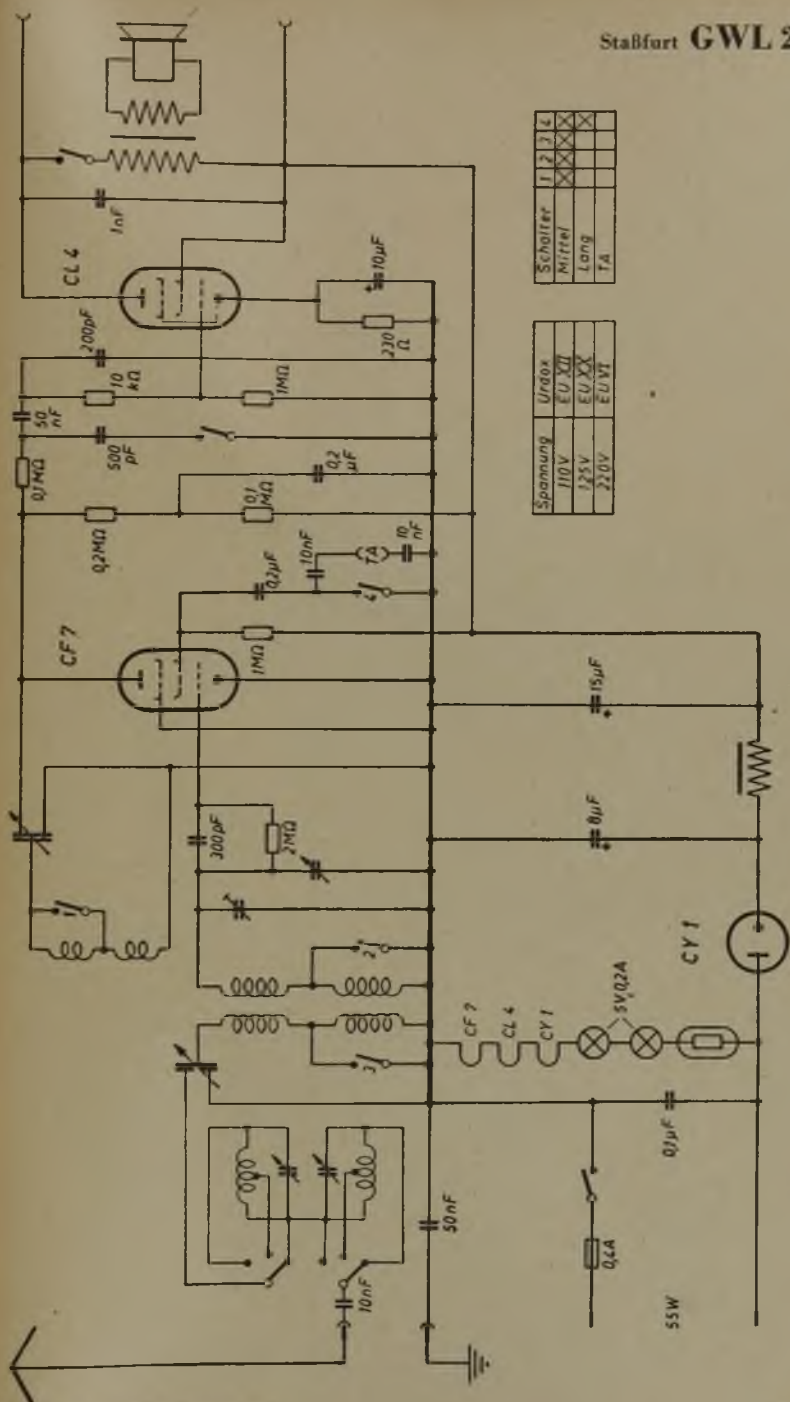

Schalter	1	2	3	4
Mittel	×	×	×	×
Lang				
FA				

Urdox	EU XII
Spannung	110V
	125V
	220V
	EU VI

Staffurt LW 27

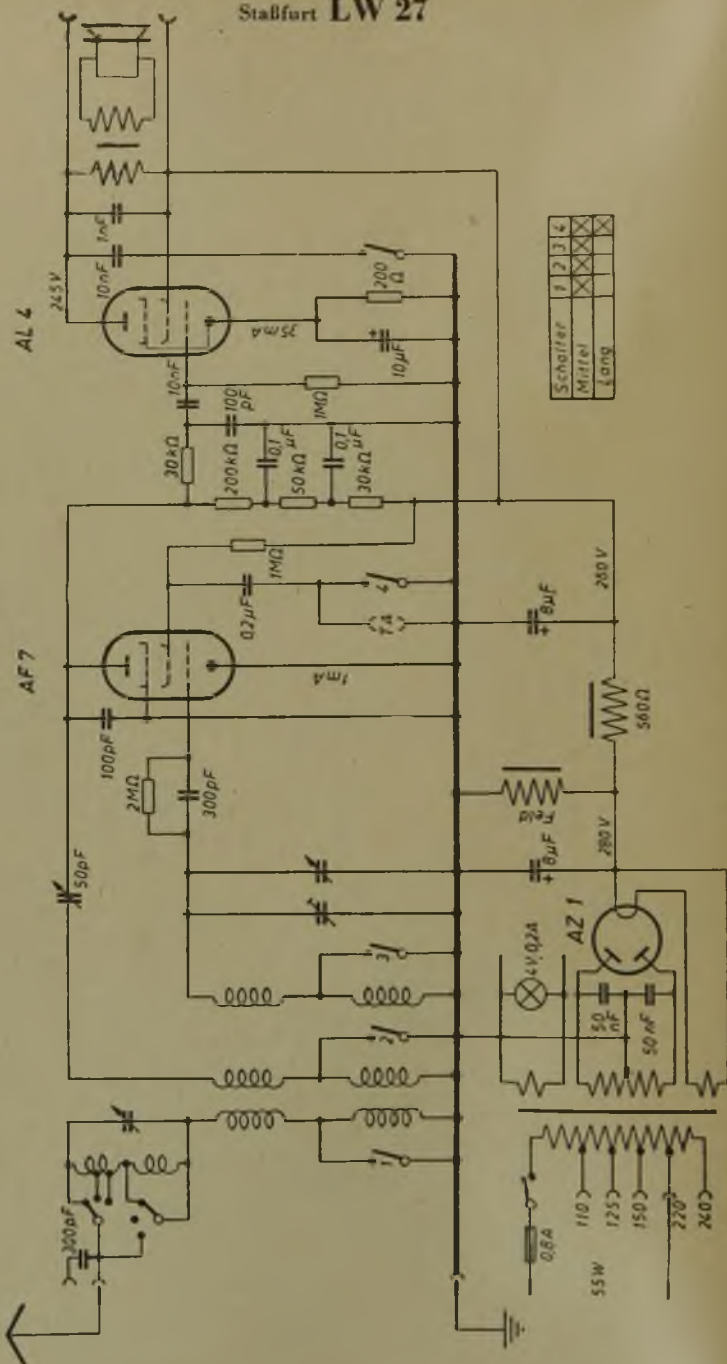

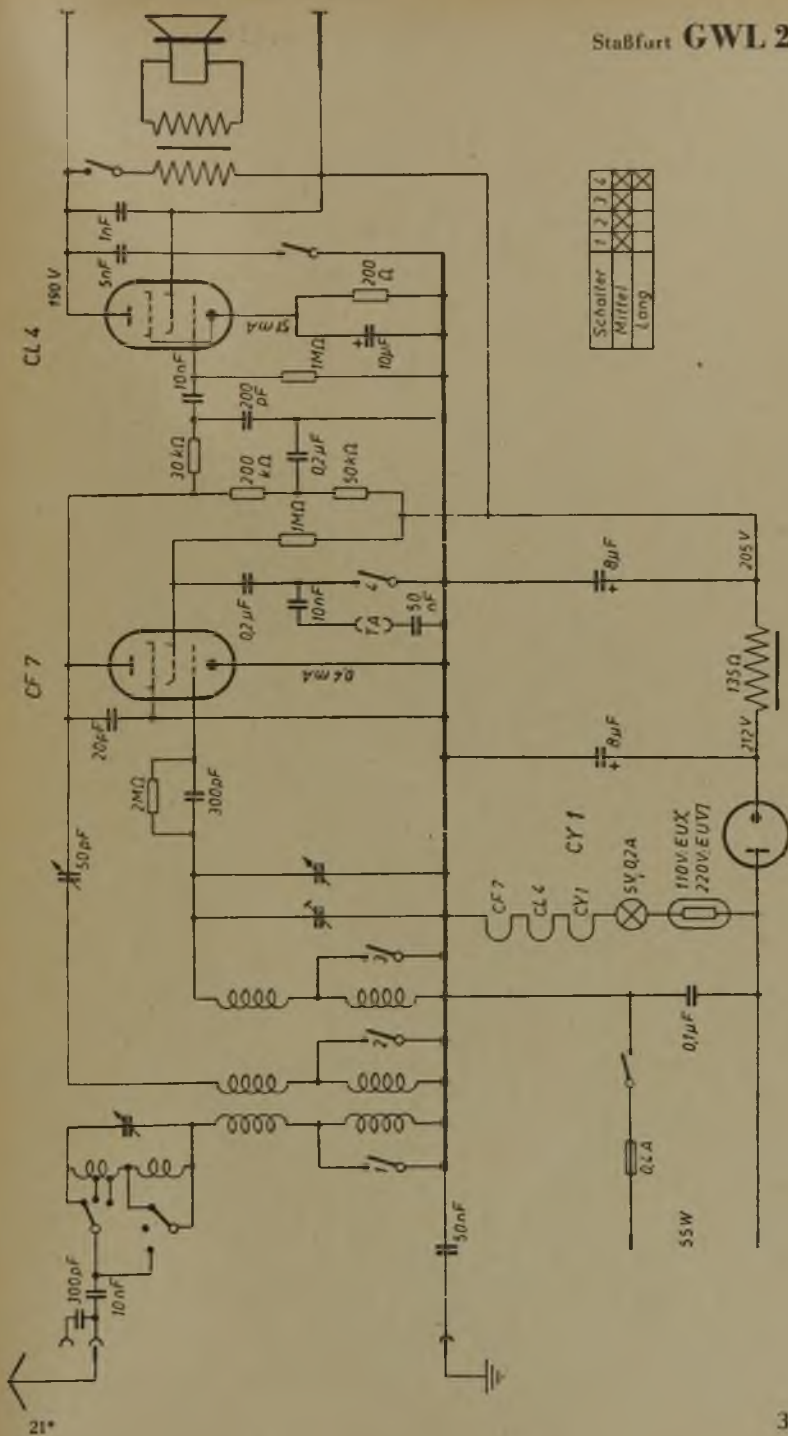

Staßfurt Imperial 6 W

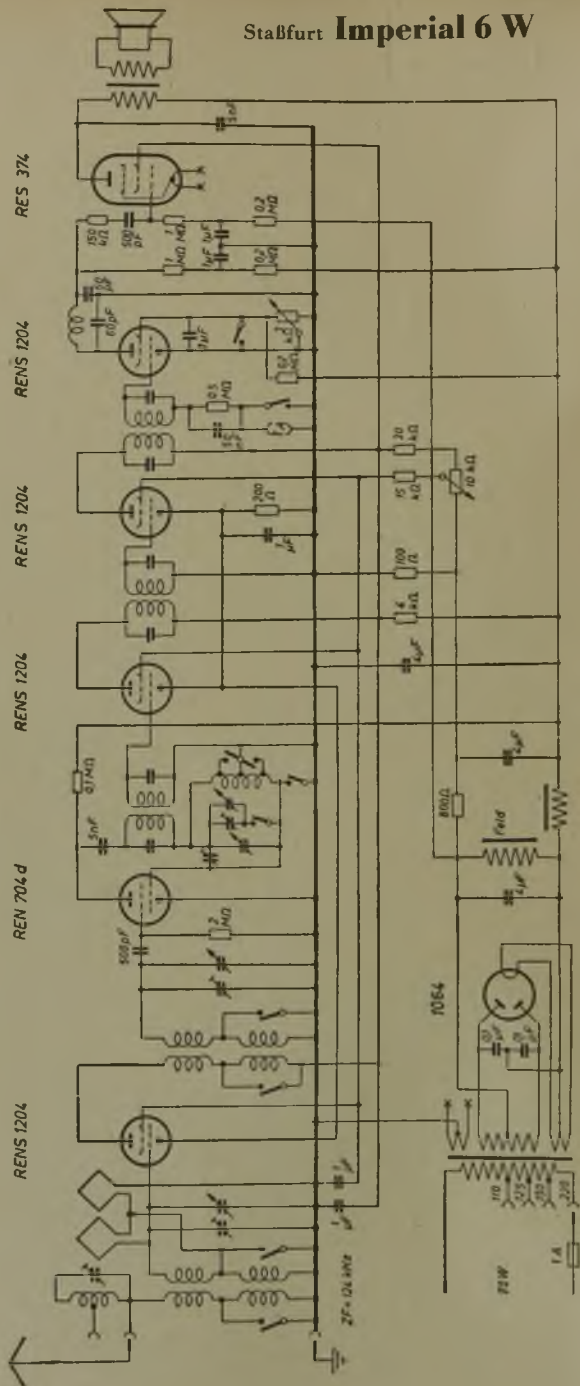

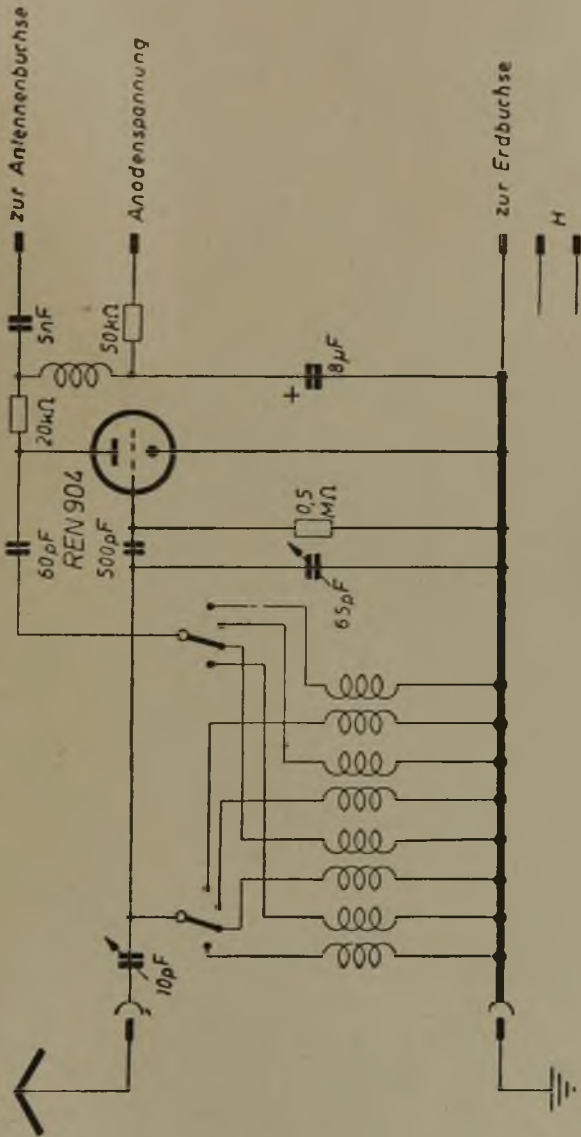

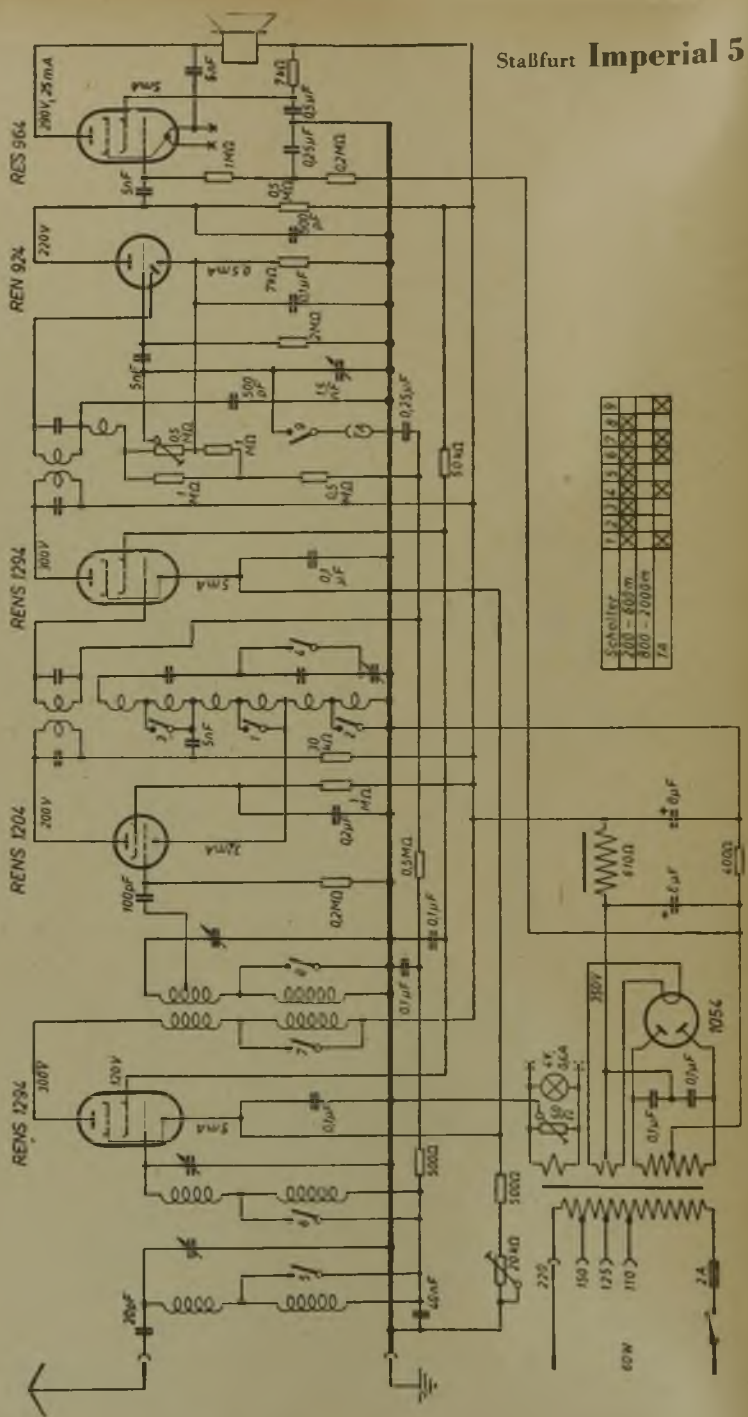

Schalter	1	2	3	4	5	6	7	8	9
400 - 600m	X	X	X	X	X	X	X	X	X
800 - 1000m	X	X	X	X	X	X	X	X	X
TA	X	X	X	X	X	X	X	X	X

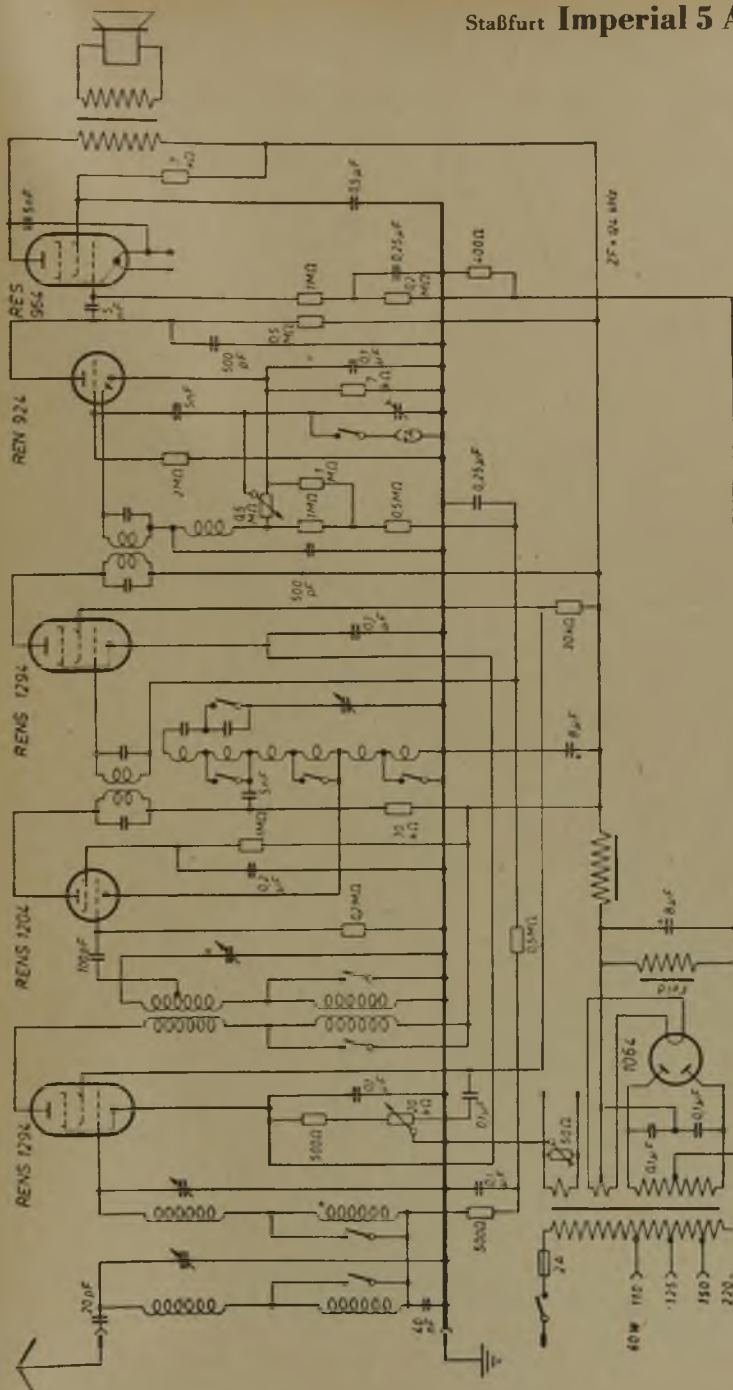

Staffurt Imperial 5 W

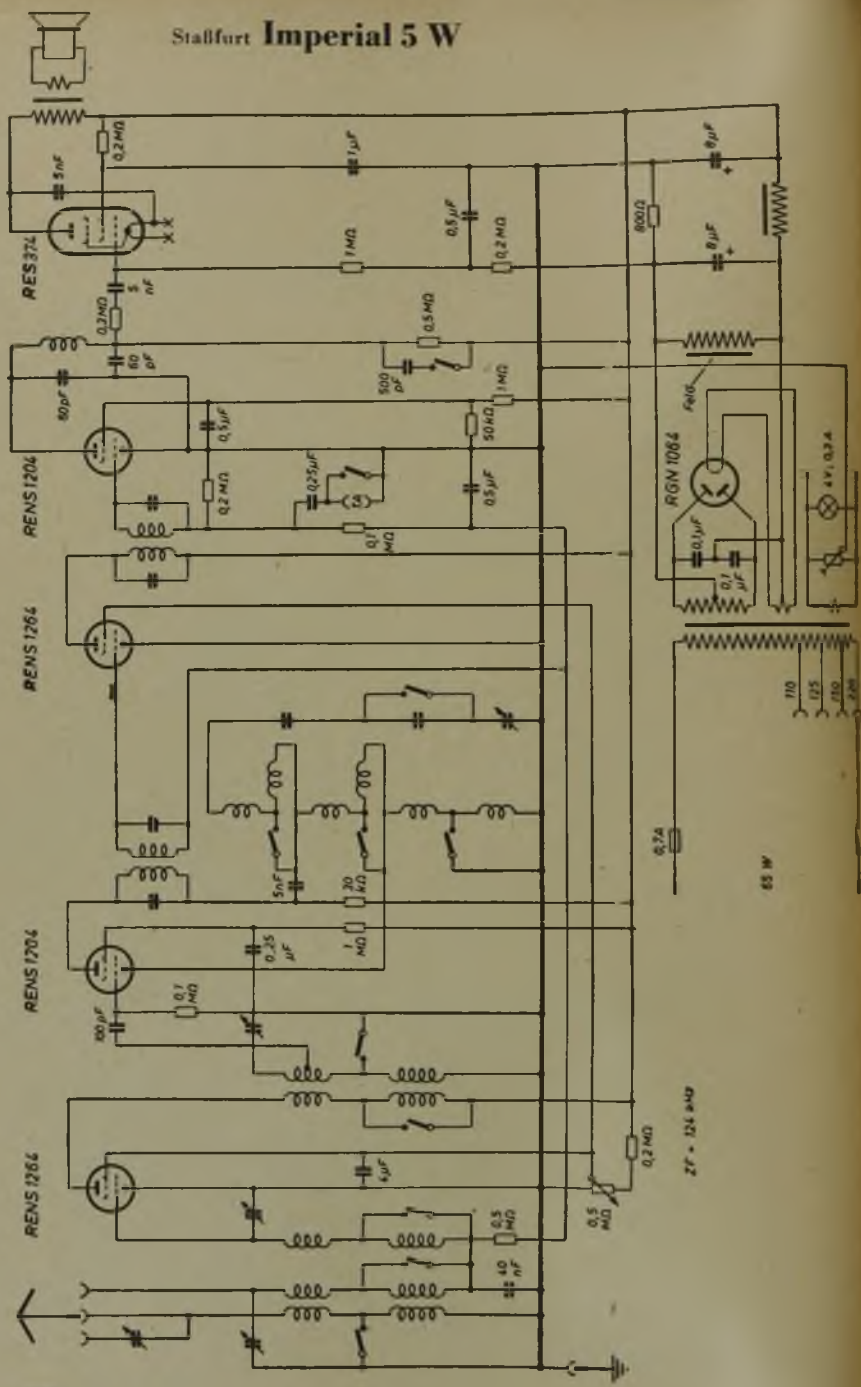

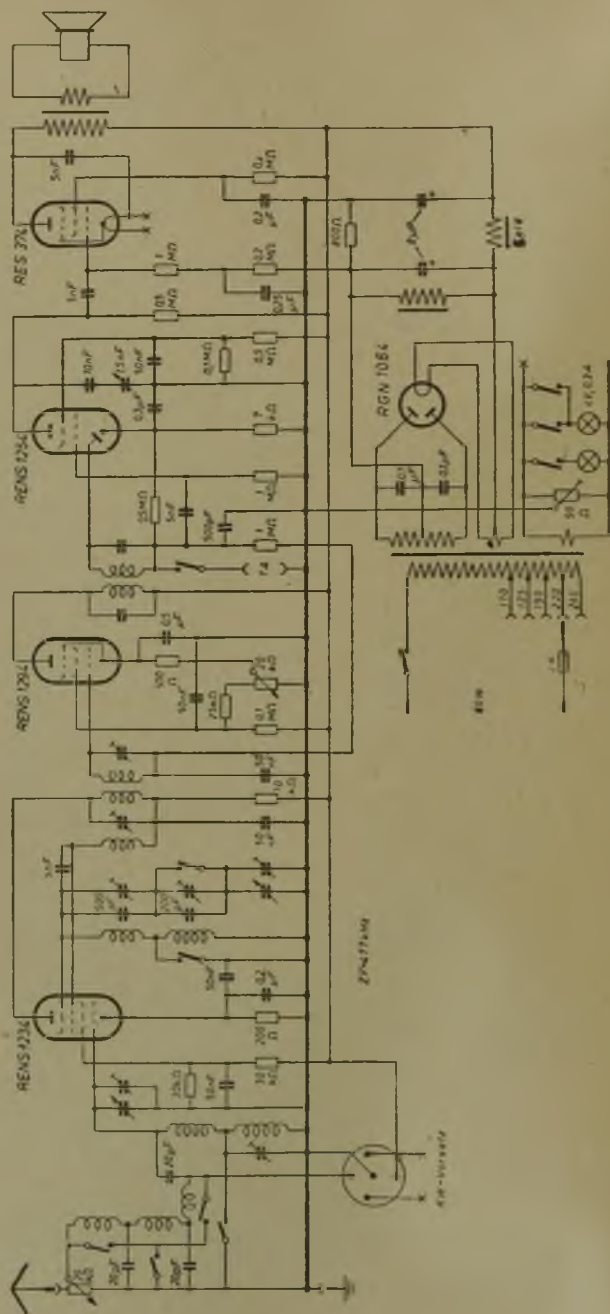

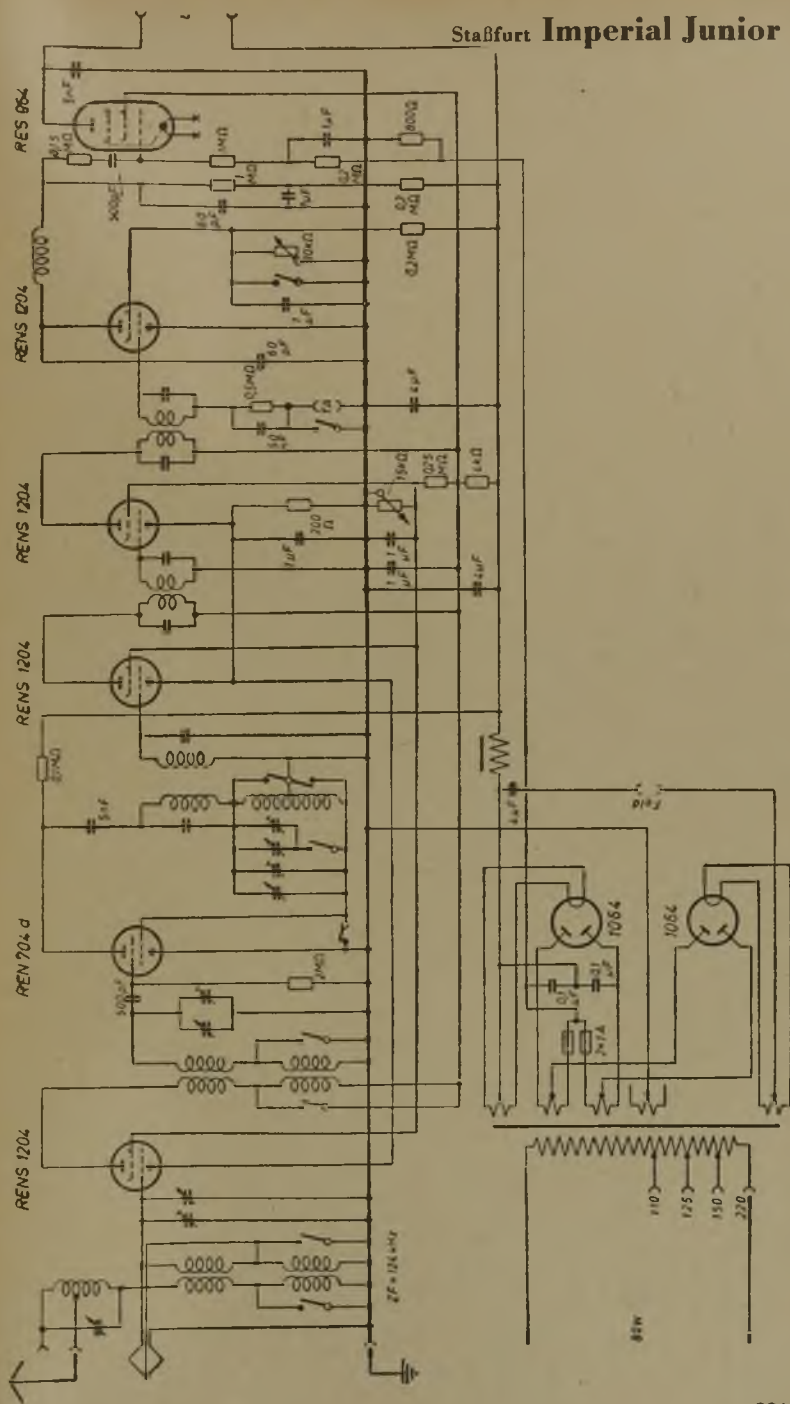



STAUDIGL

Staudigl Interpret 569 W und Studio I

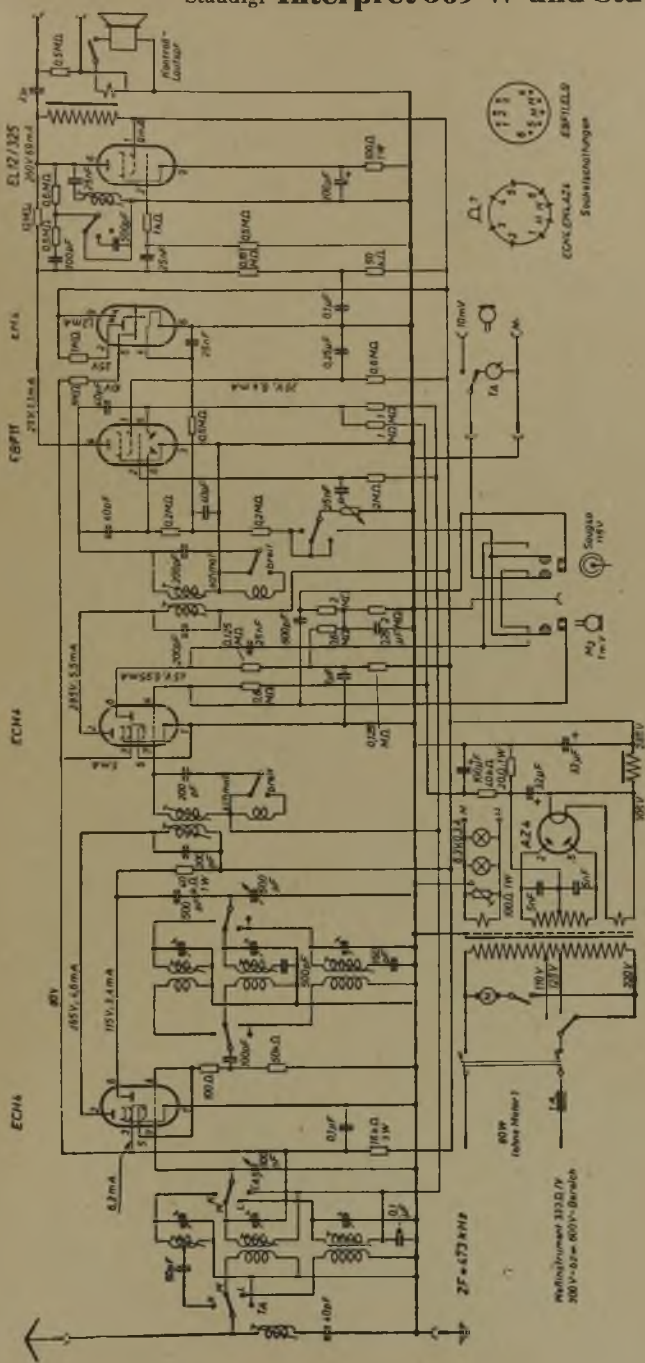

Multiinstrument 112 D/F
300V-50=600V-Baracke

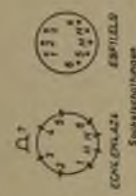

Staudigl Mentor II und Studio II

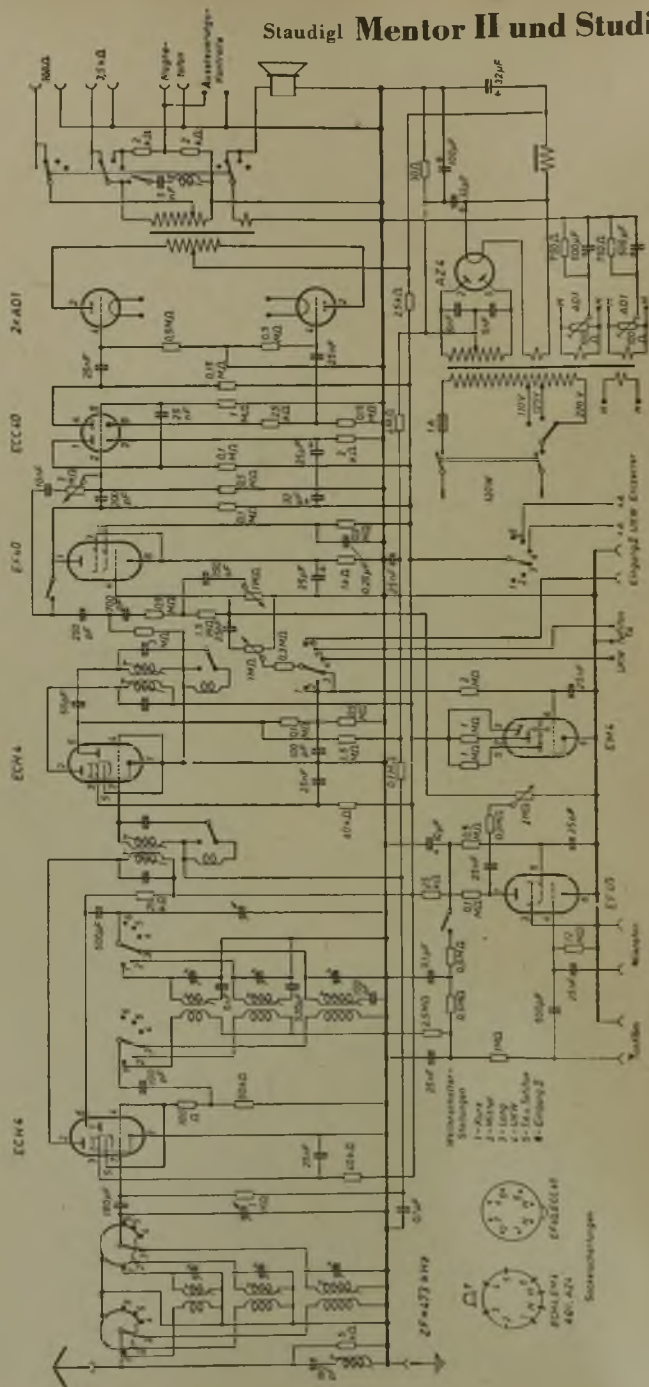

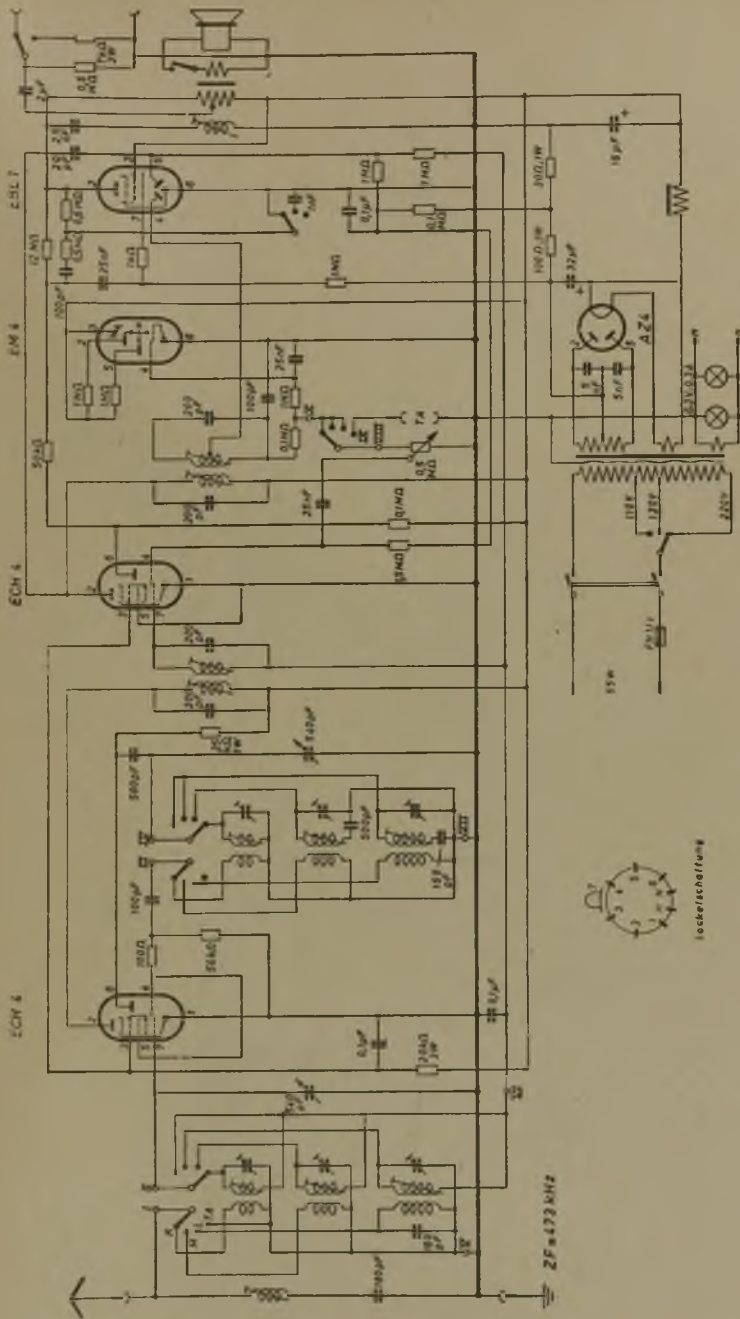

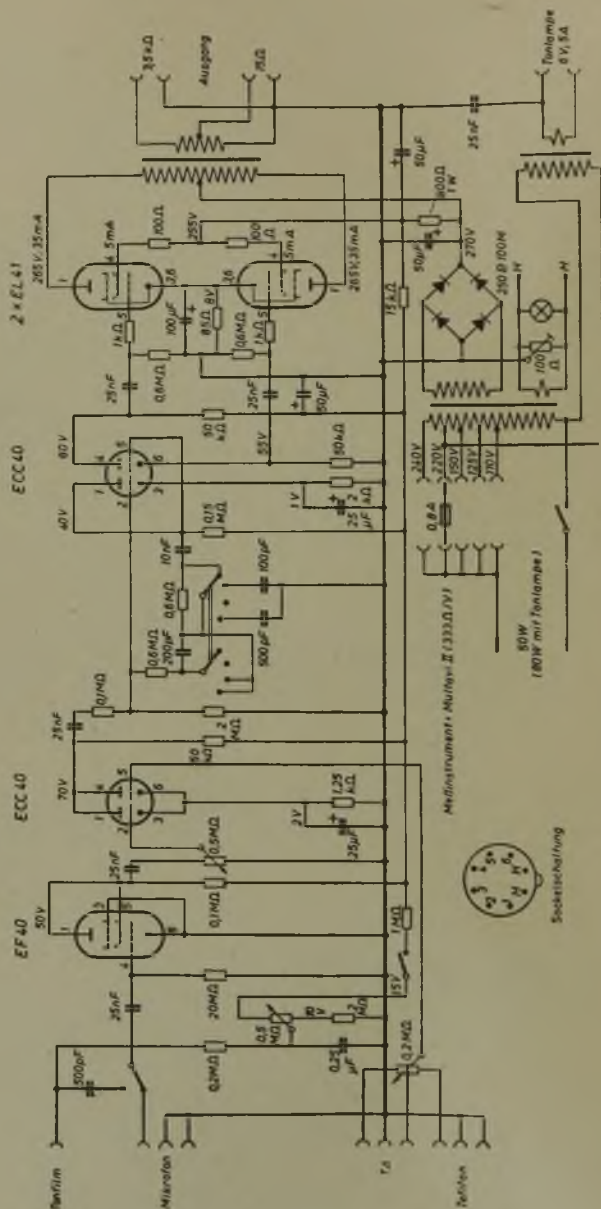

SÜDFUNK

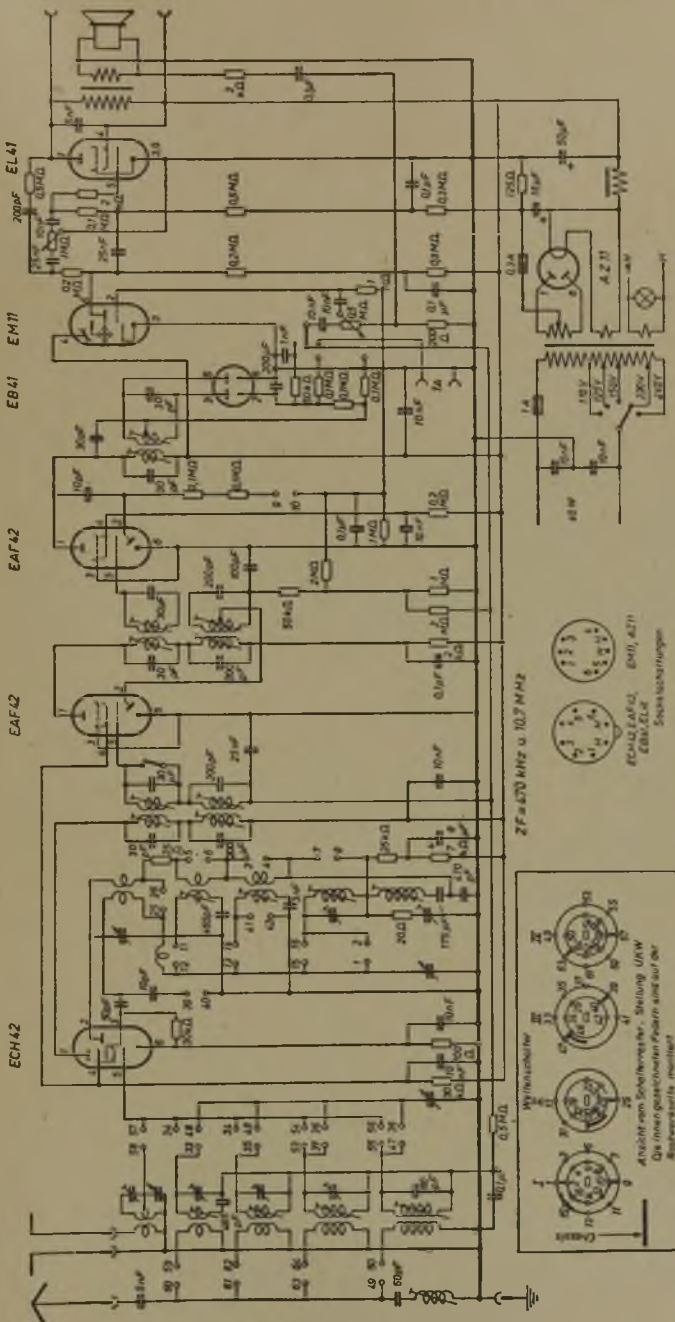

ZF = 270 kHz u. 10,7 MHz
 6CA2, 6AF2, 6M7, 6Z7
 EB41, EL41
 Sockelbuchungen

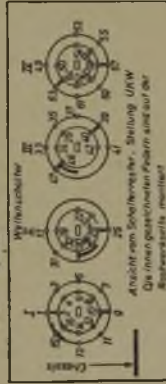



TAK



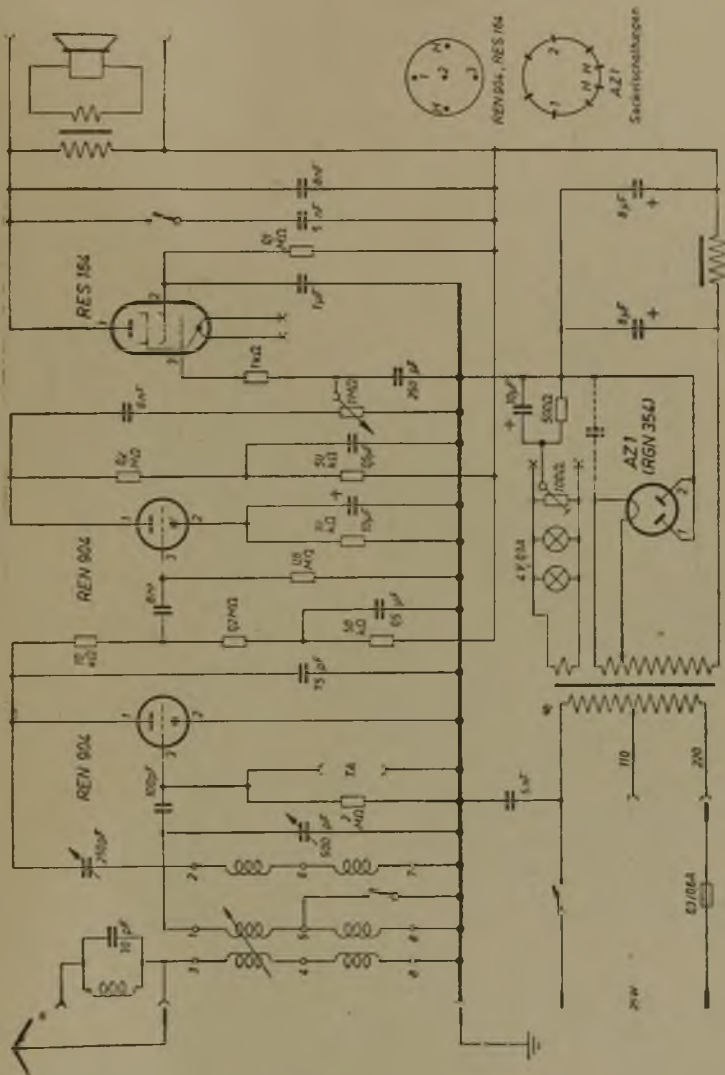

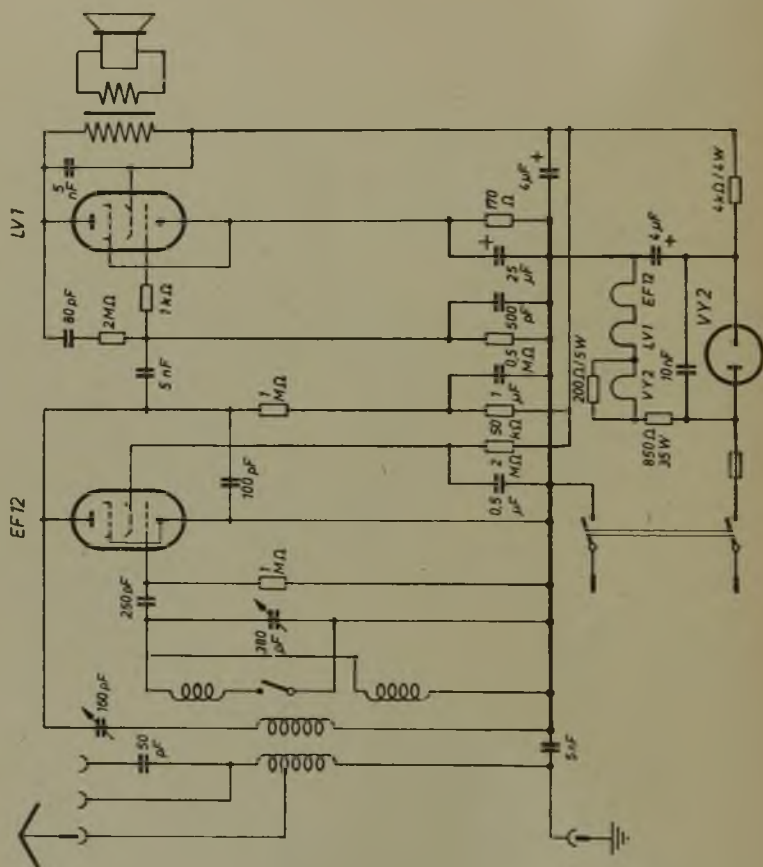

TEFAG



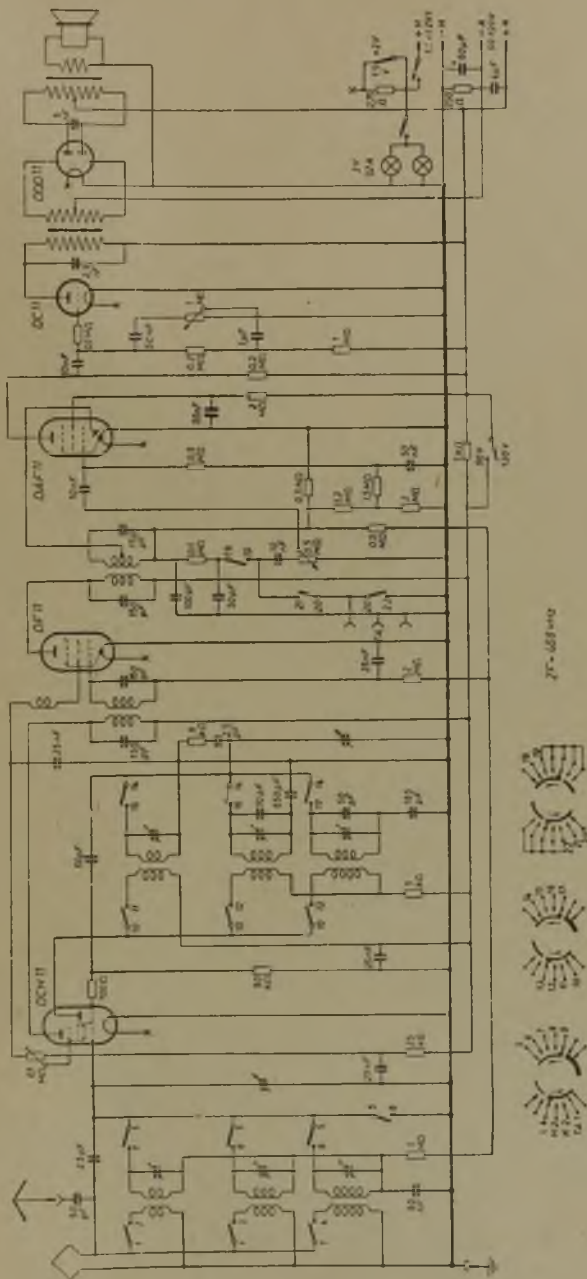

Tefag BT 410 und 30 B

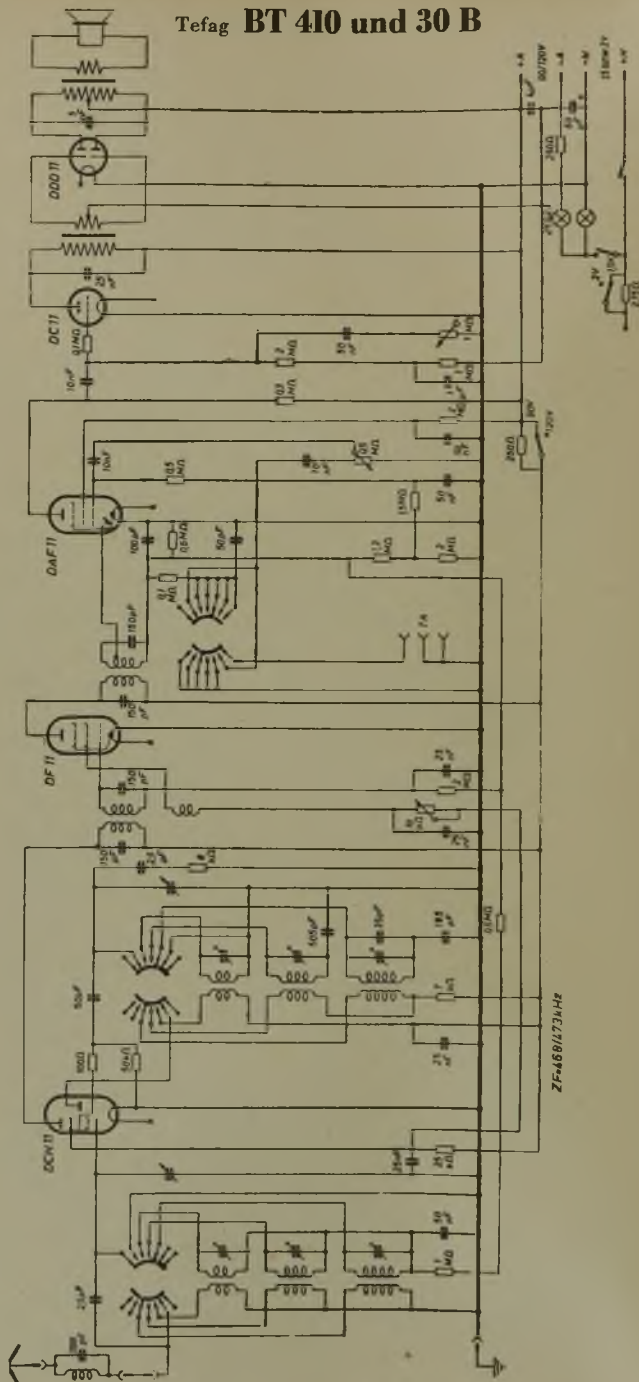

ZF=468/473kHz

Tefag **BT 400**
(linke Seite des Schaltbildes)

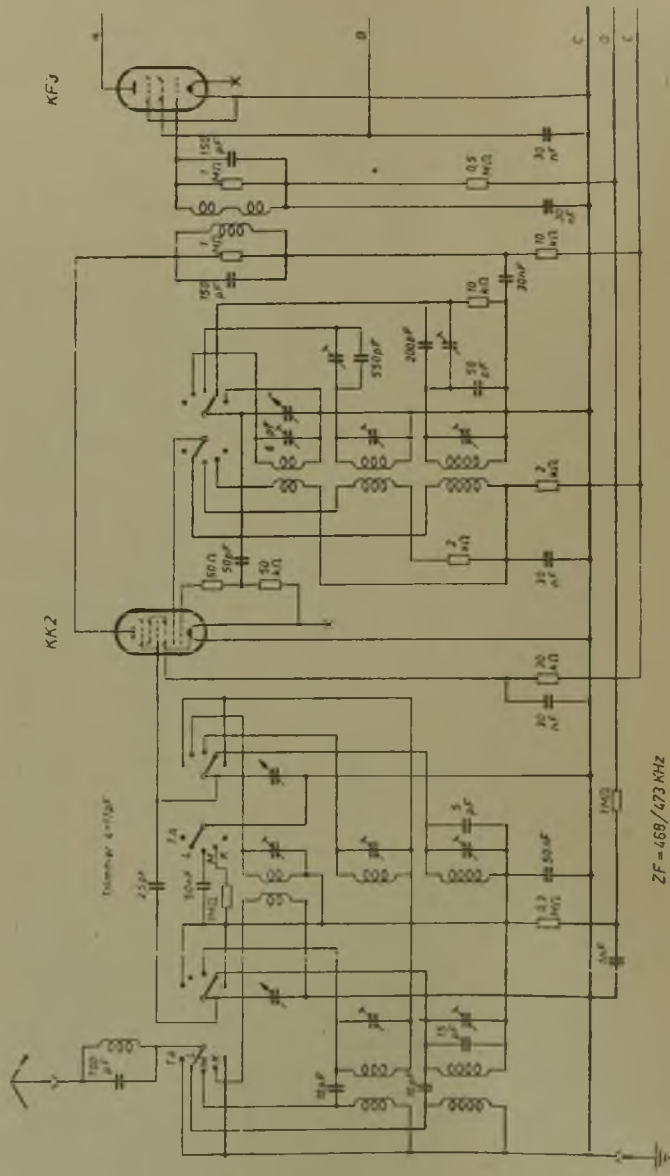

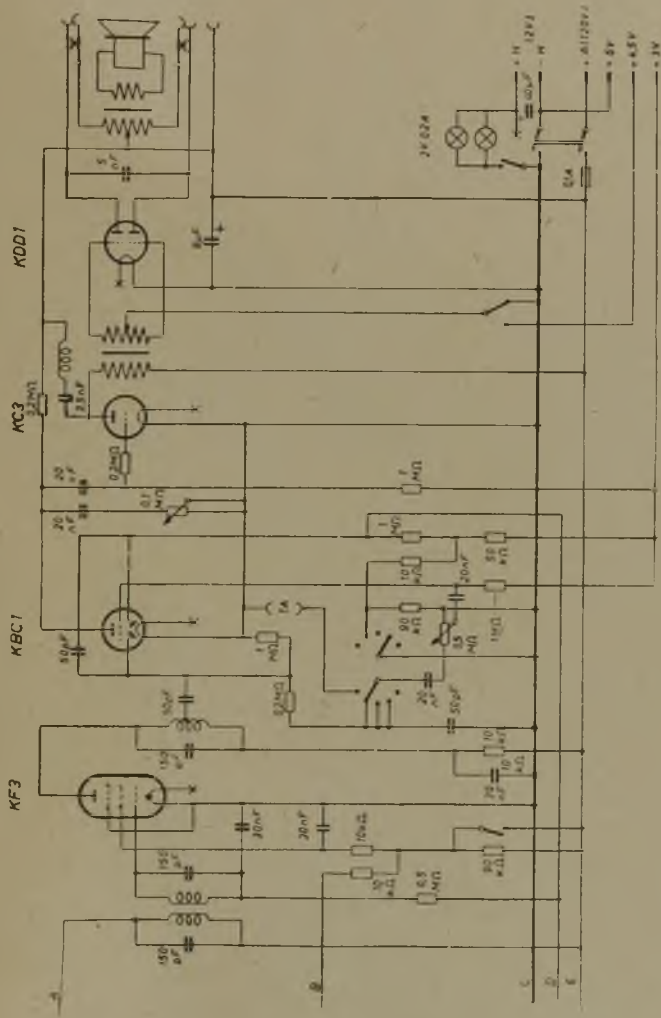

Tefag 300 W
 (linke Seite des Schaltbildes)

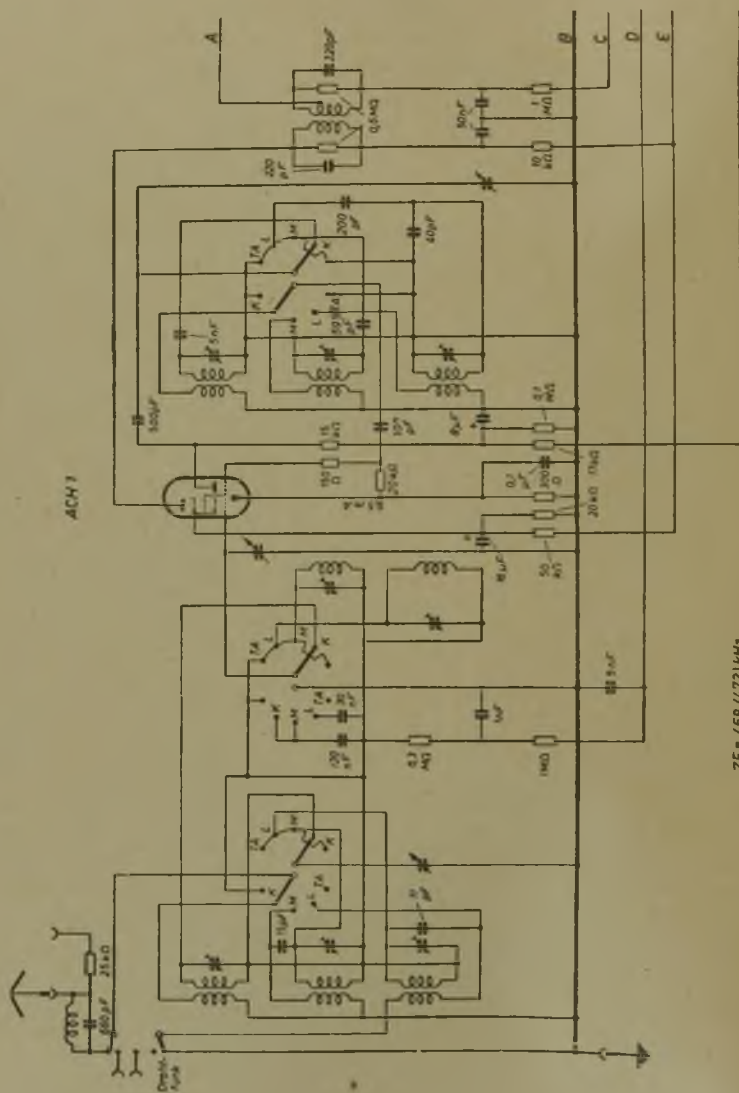

ZF = 468 (1.73) MHz

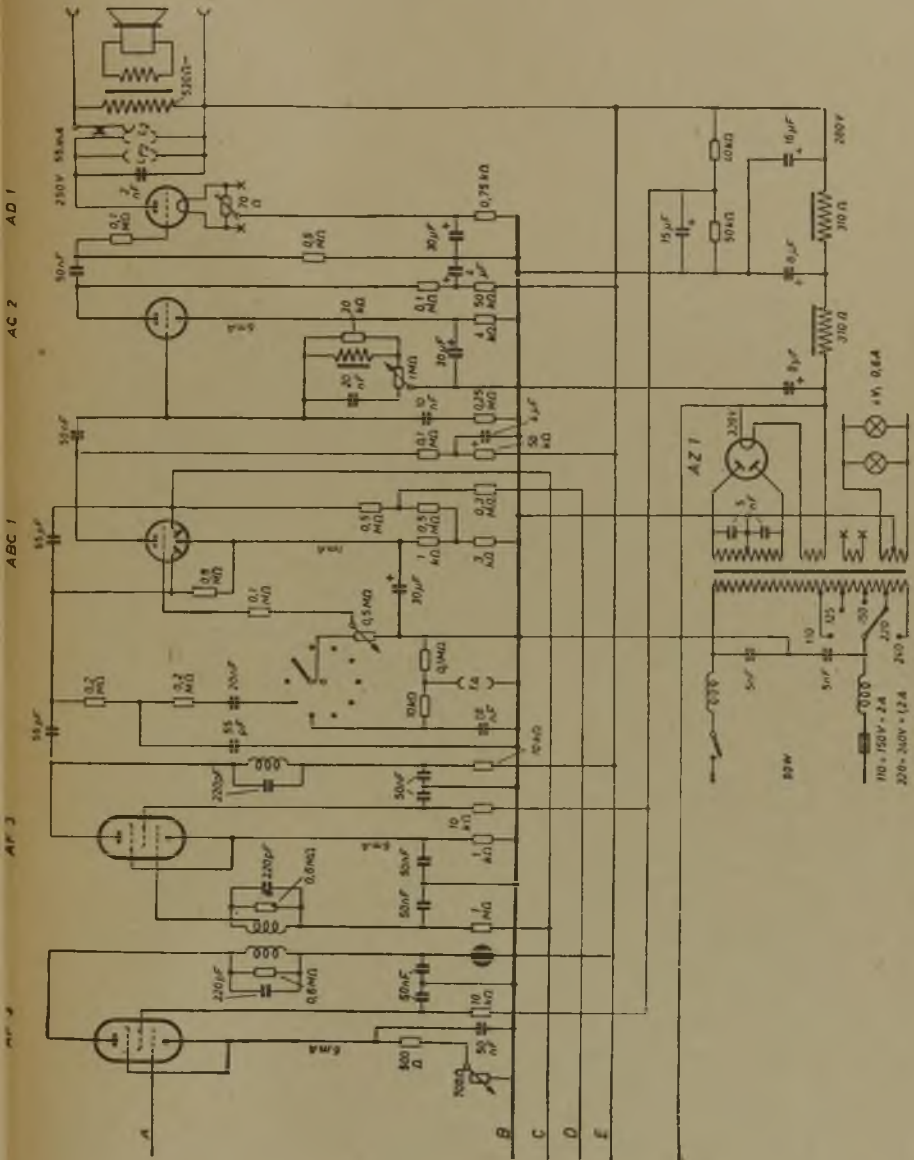

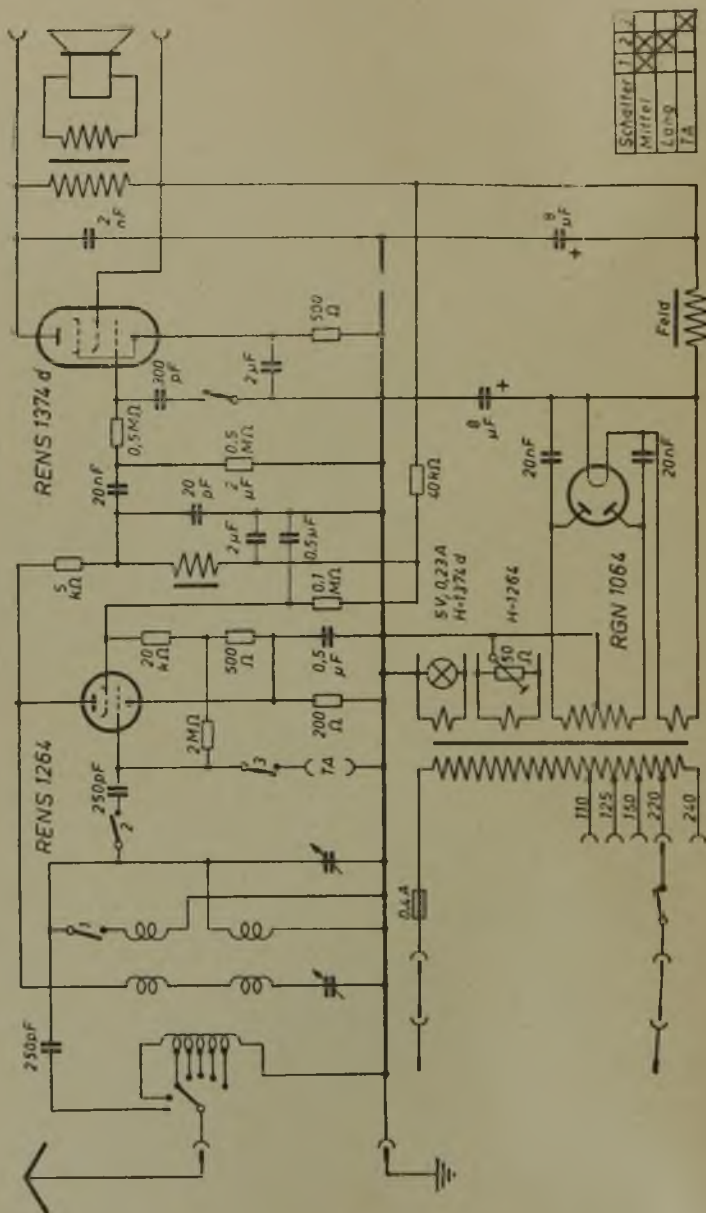

Schalter	1	2	3
Mittel	×	×	×
Lang	×	×	×
TA	×	×	×

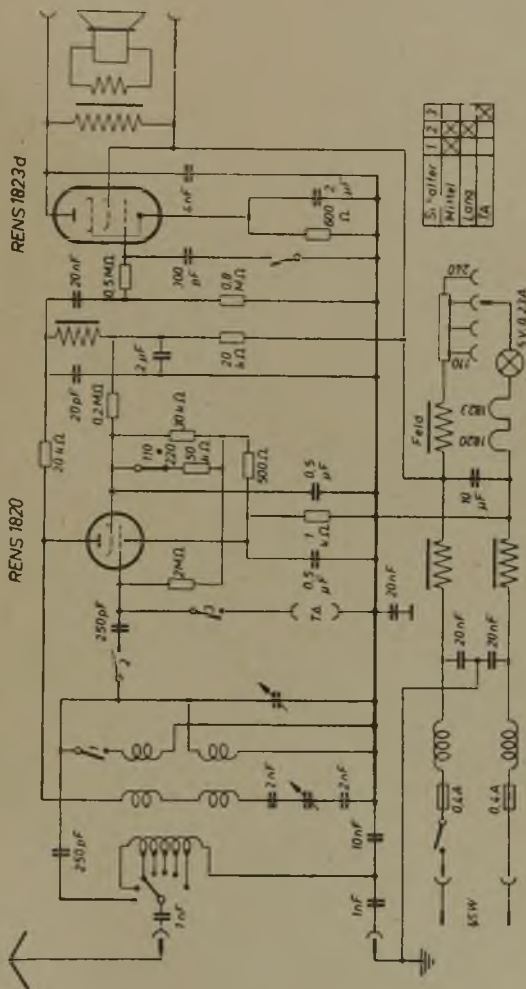

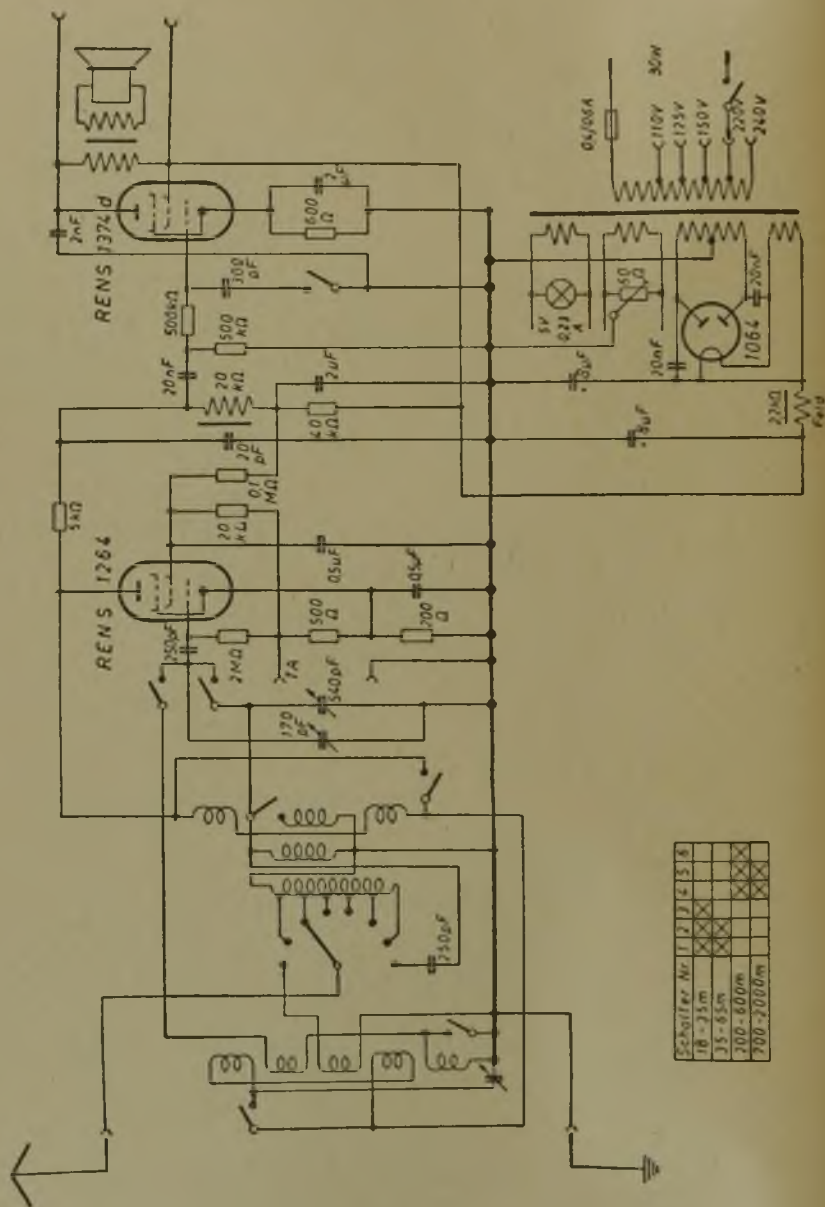

Schalter Nr.	1	2	3	4	5	6
18 - 25 m	X	X	X	X	X	X
35 - 65 m	X	X	X	X	X	X
100 - 600 m	X	X	X	X	X	X
700 - 2000 m	X	X	X	X	X	X

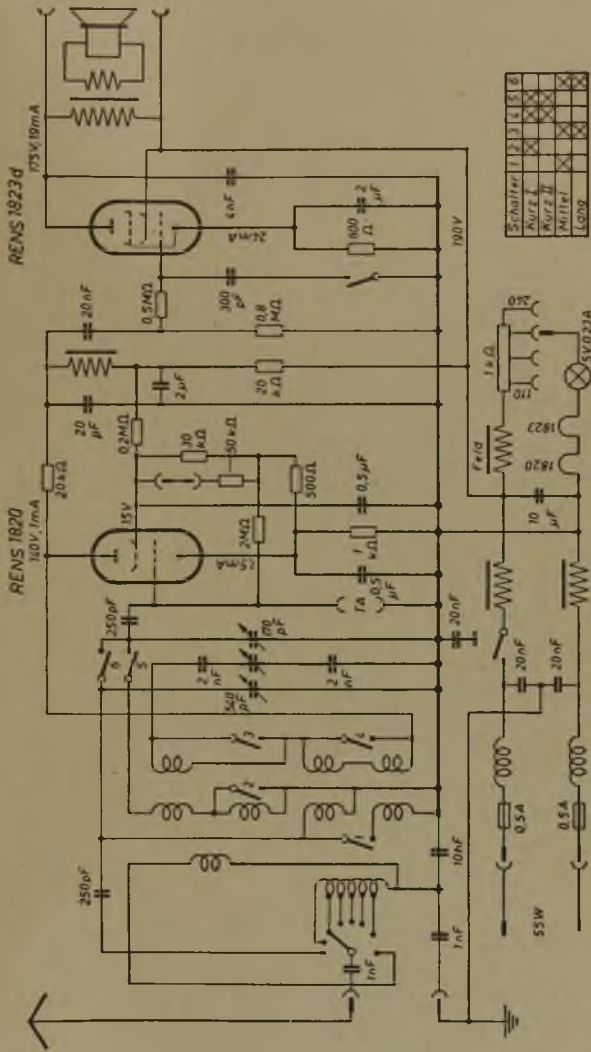

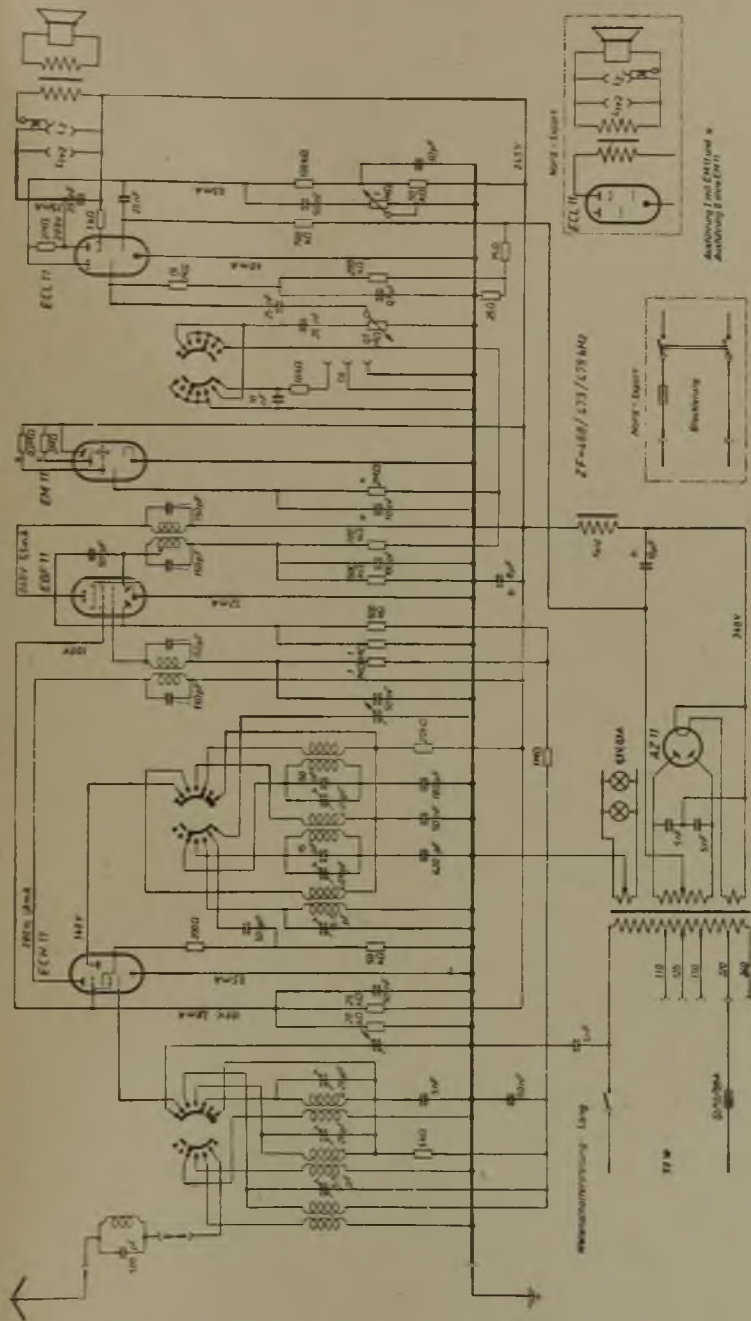

Tefag 30 A und 30 / II A

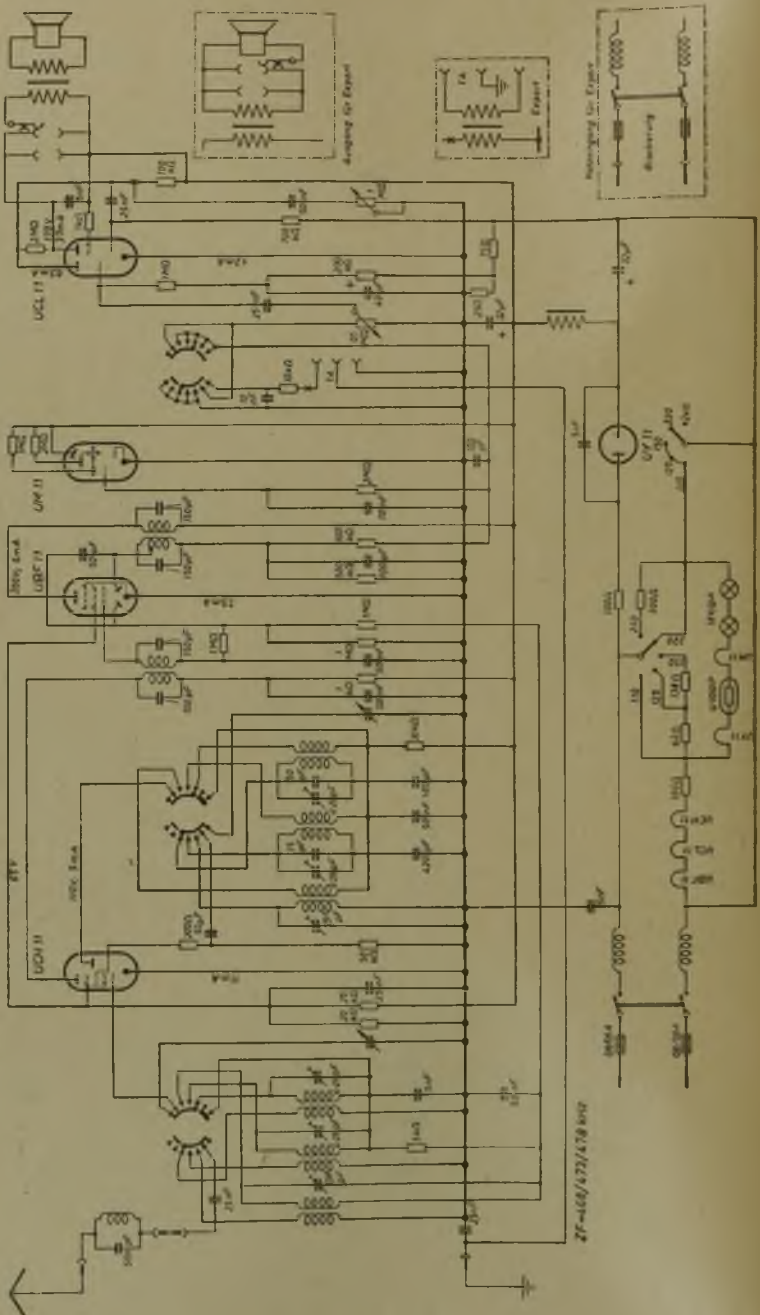

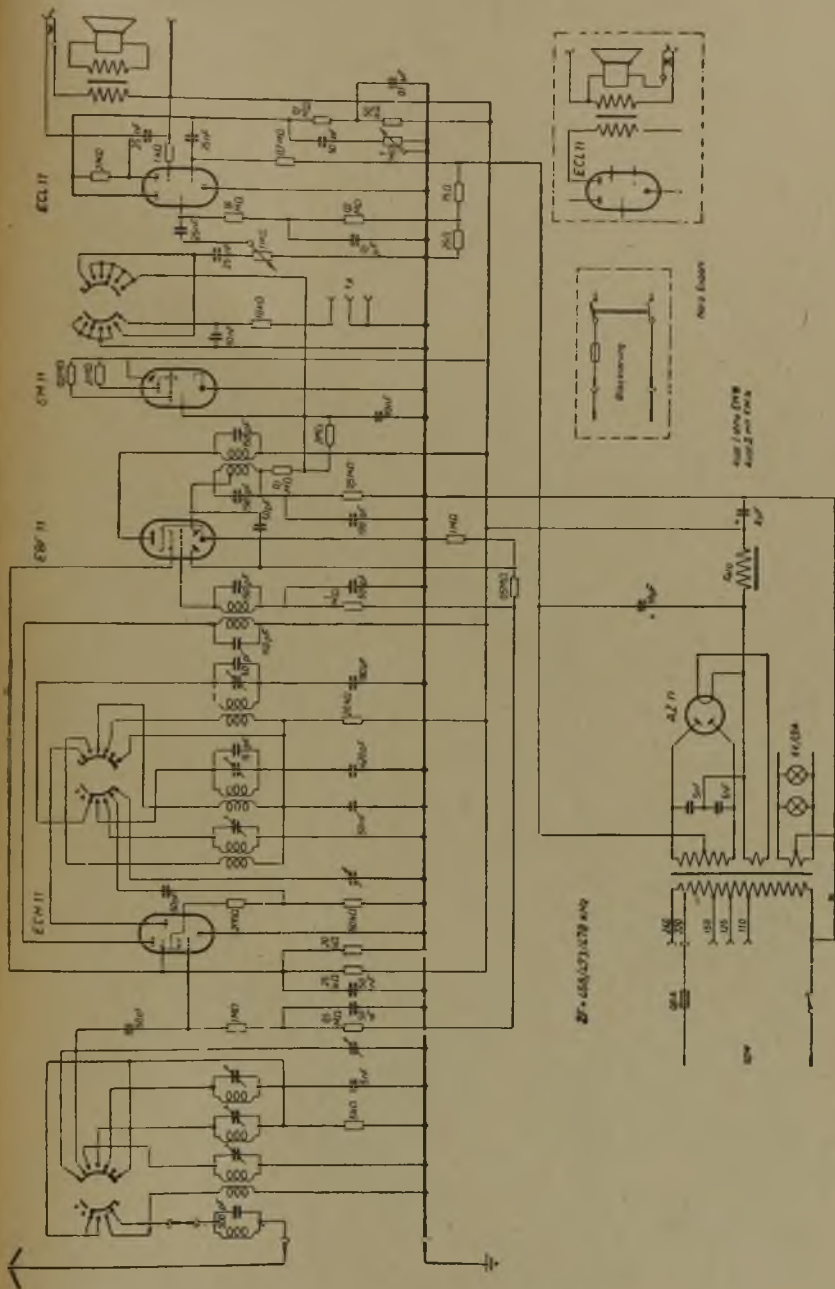

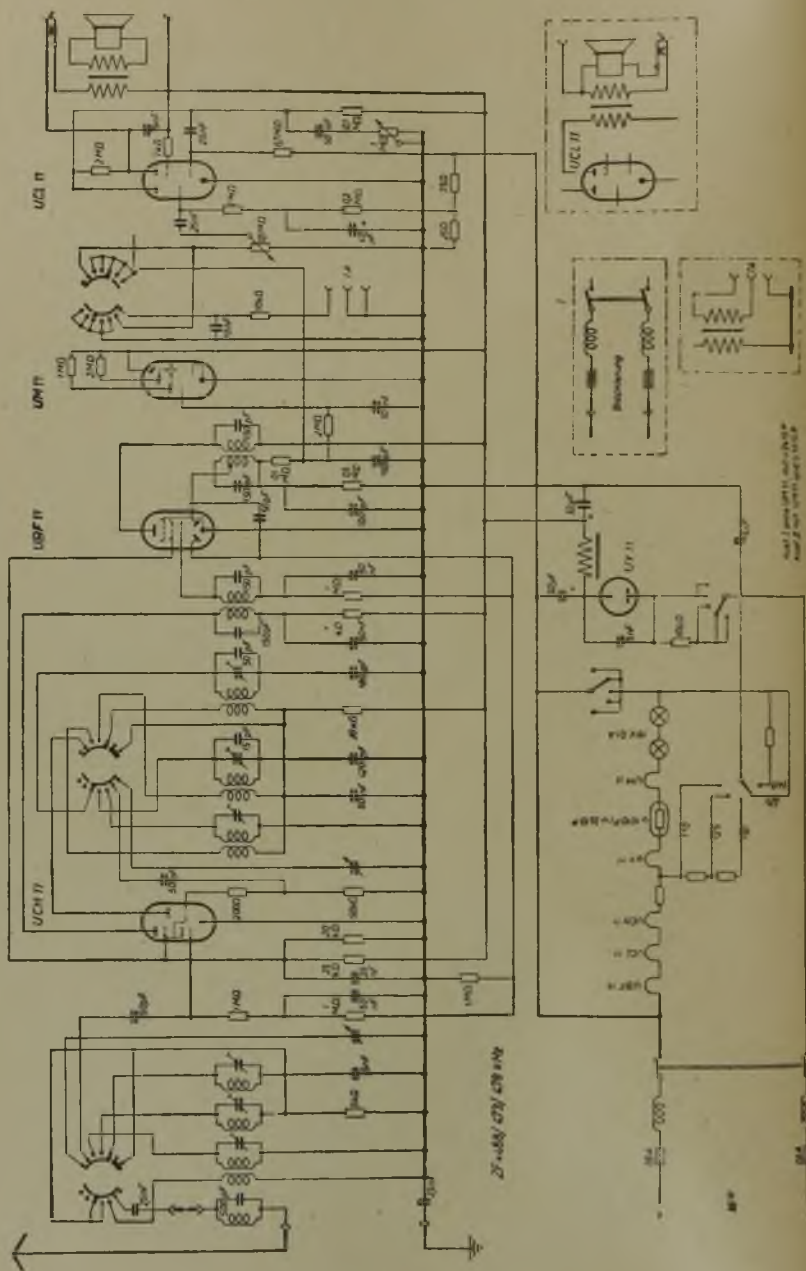

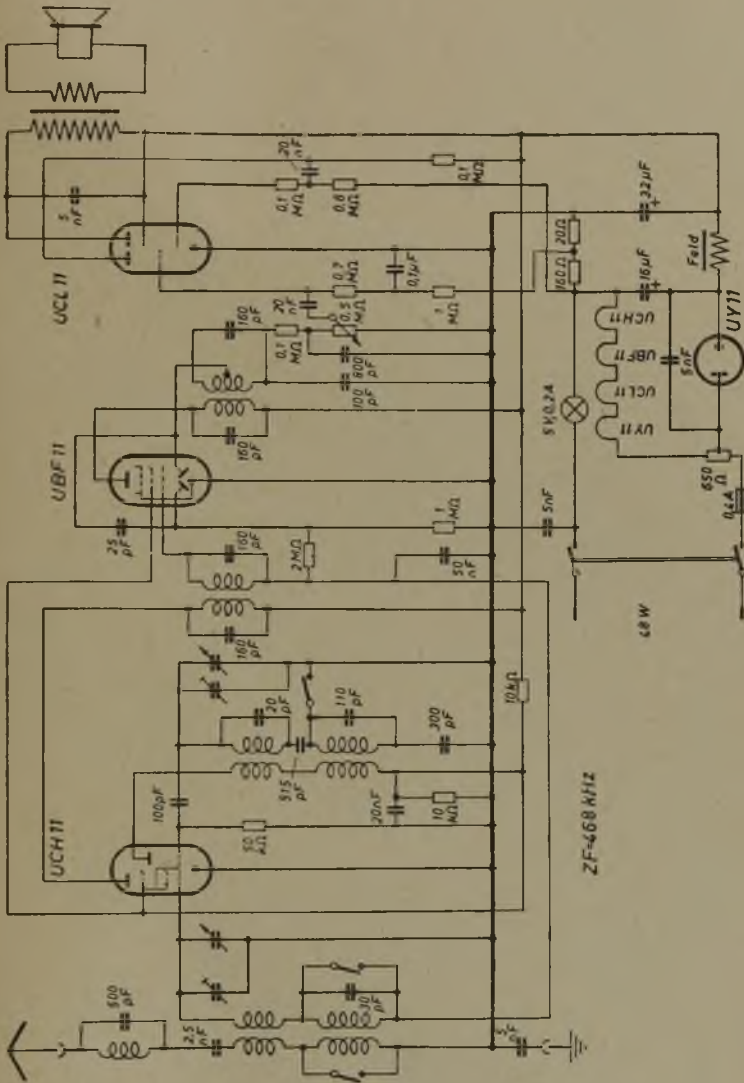

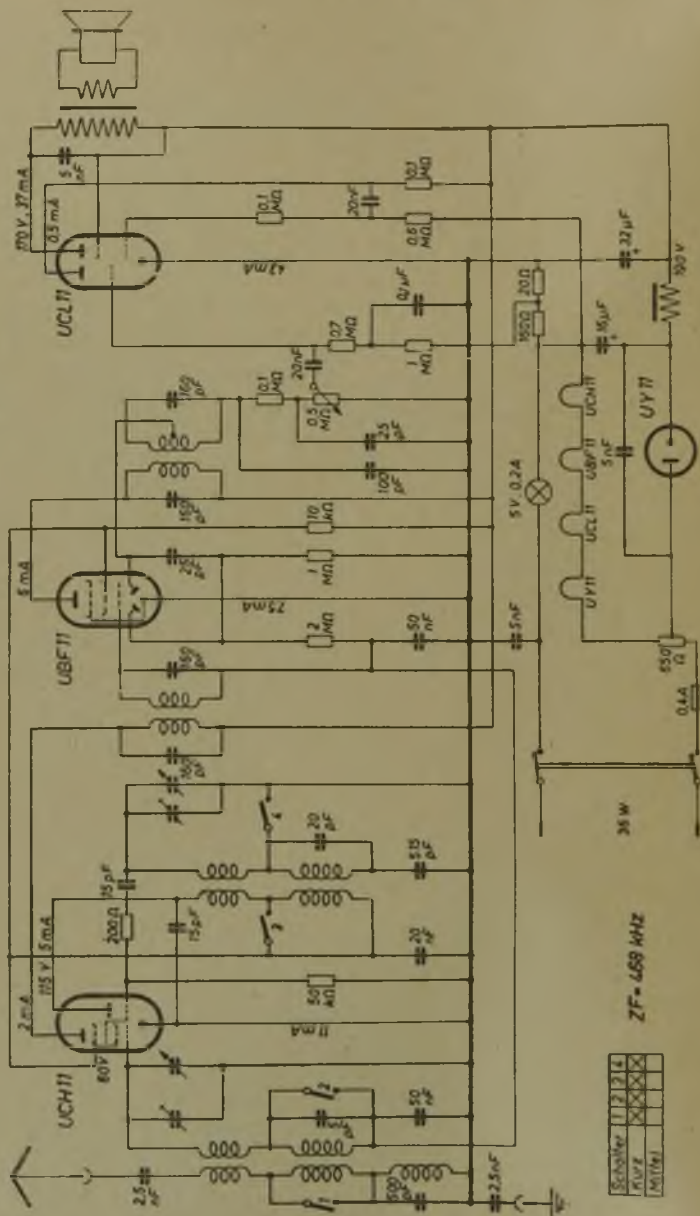

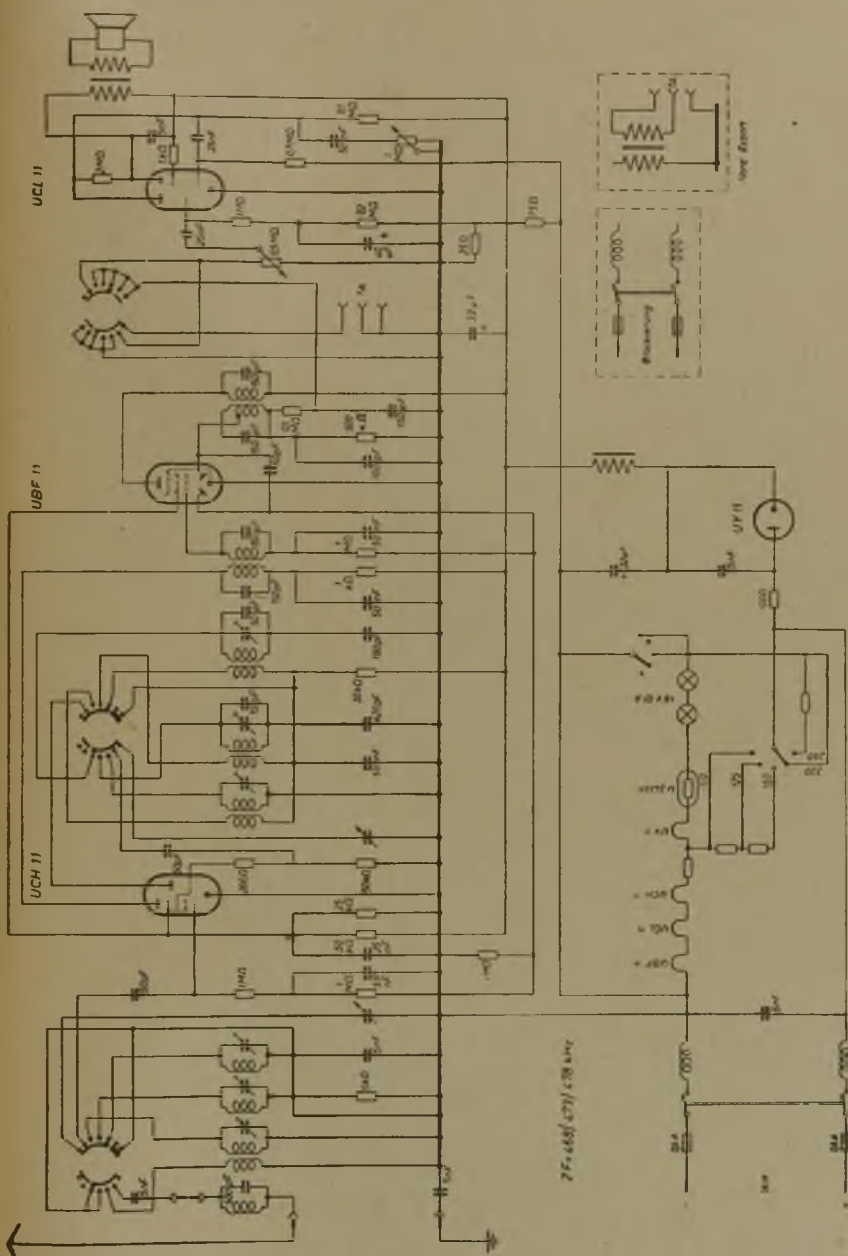

Tefag Bandfilter-Drei

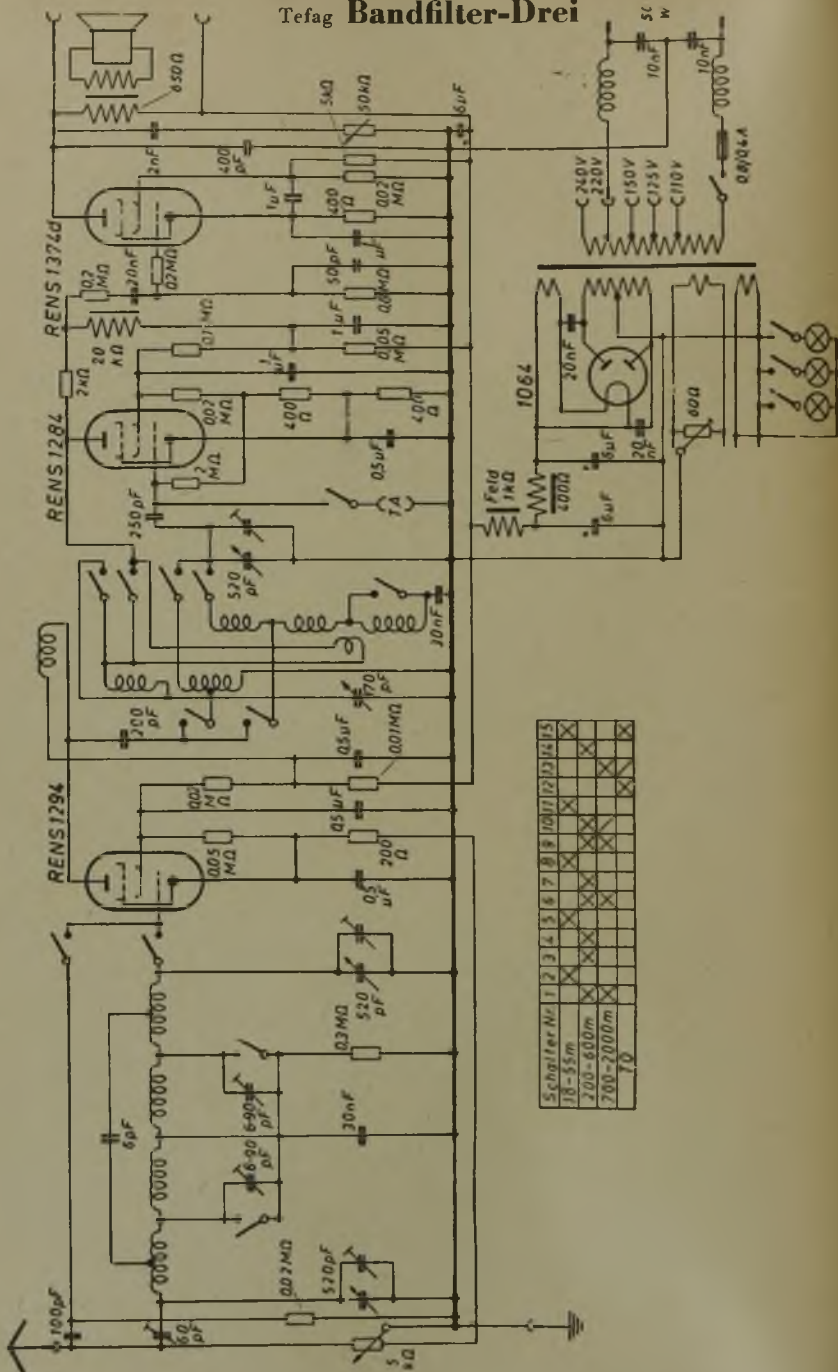

Schalter Nr	1	2	3	4	5	6	7	8	9	10	11	12	13	14	15
18-55m															
200-600m															
700-2000m															

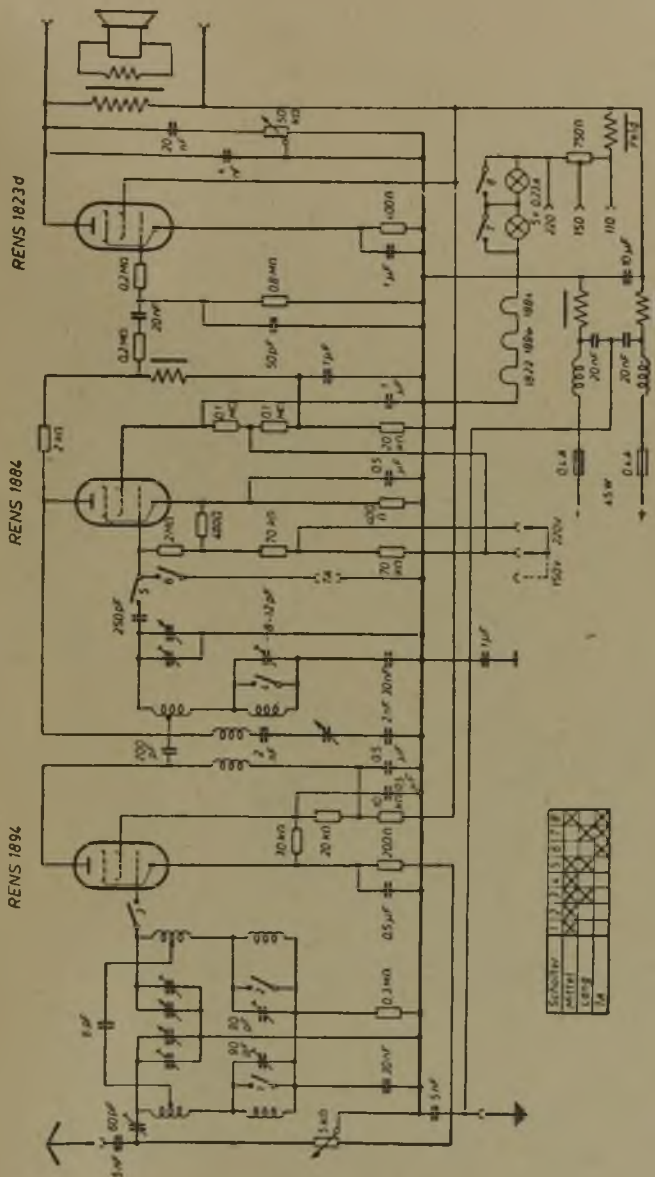

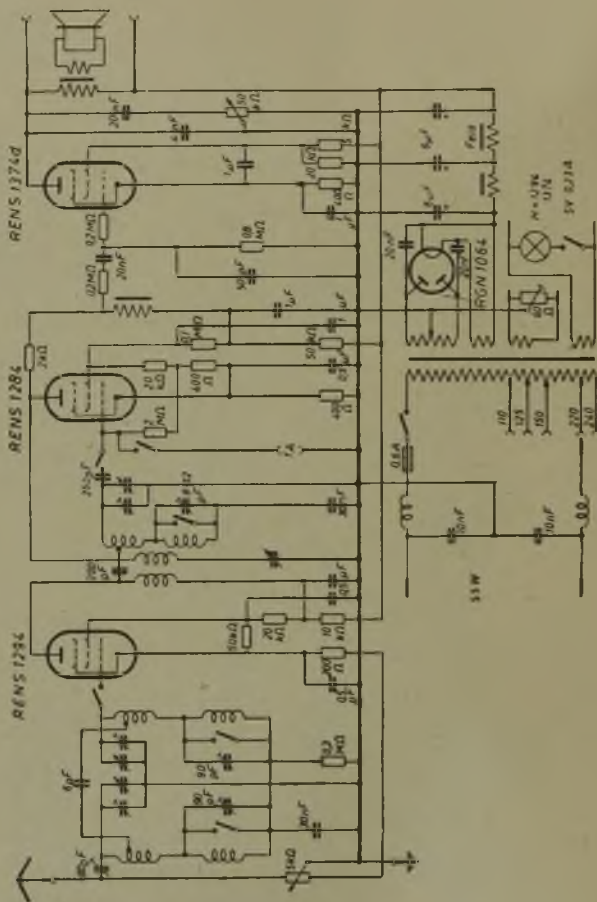

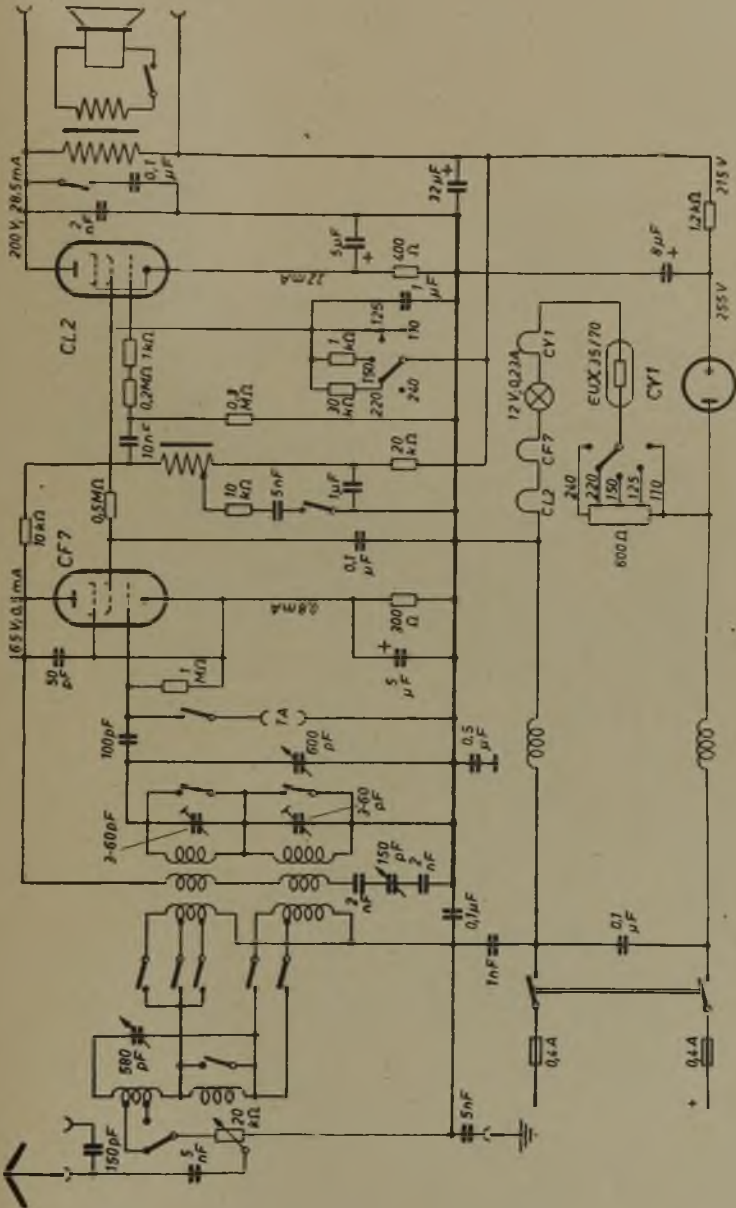

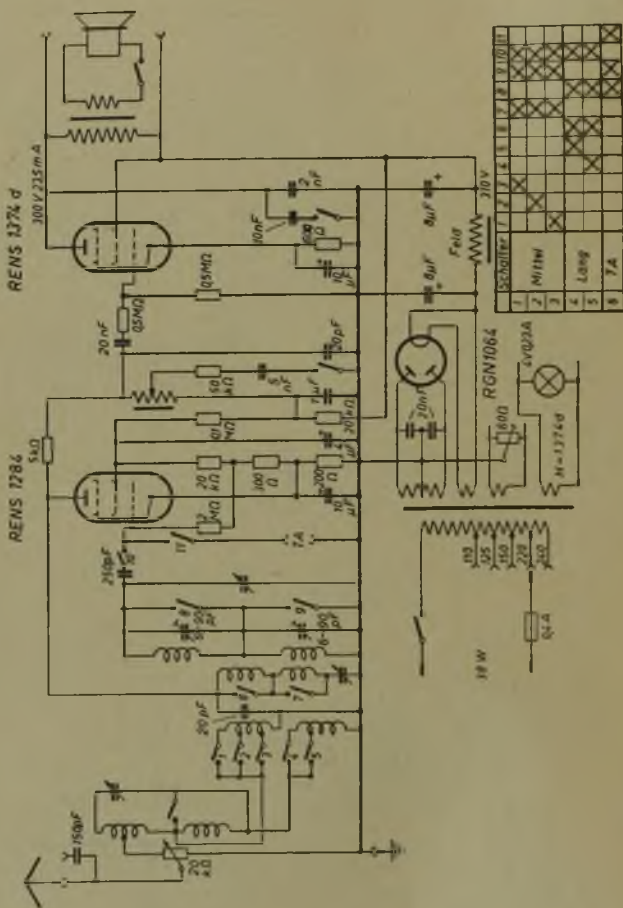

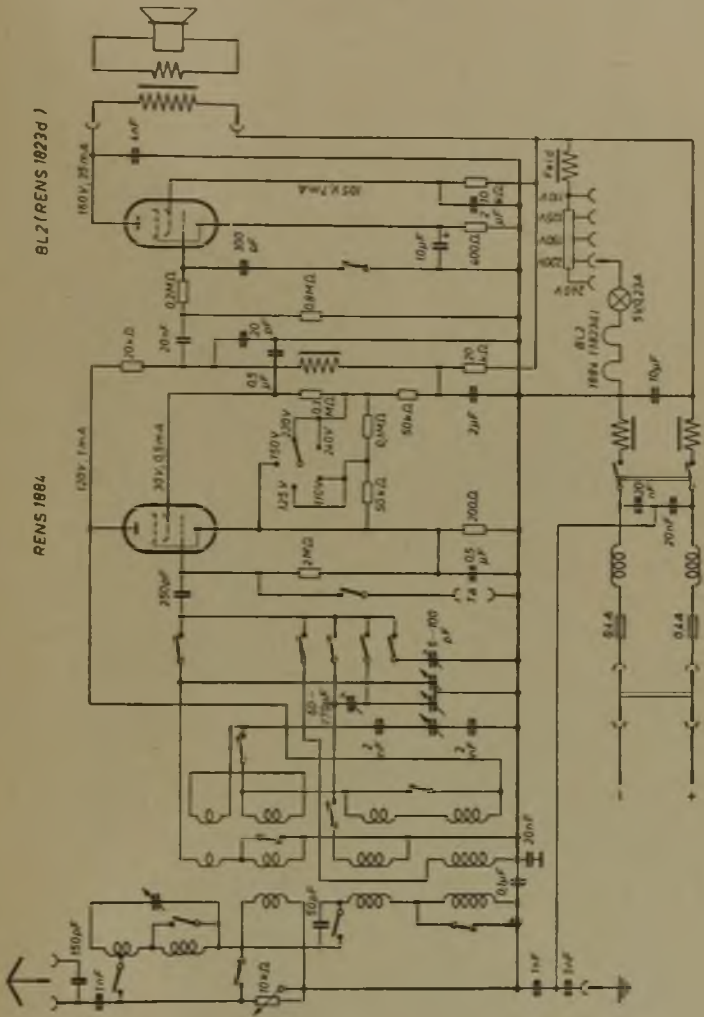

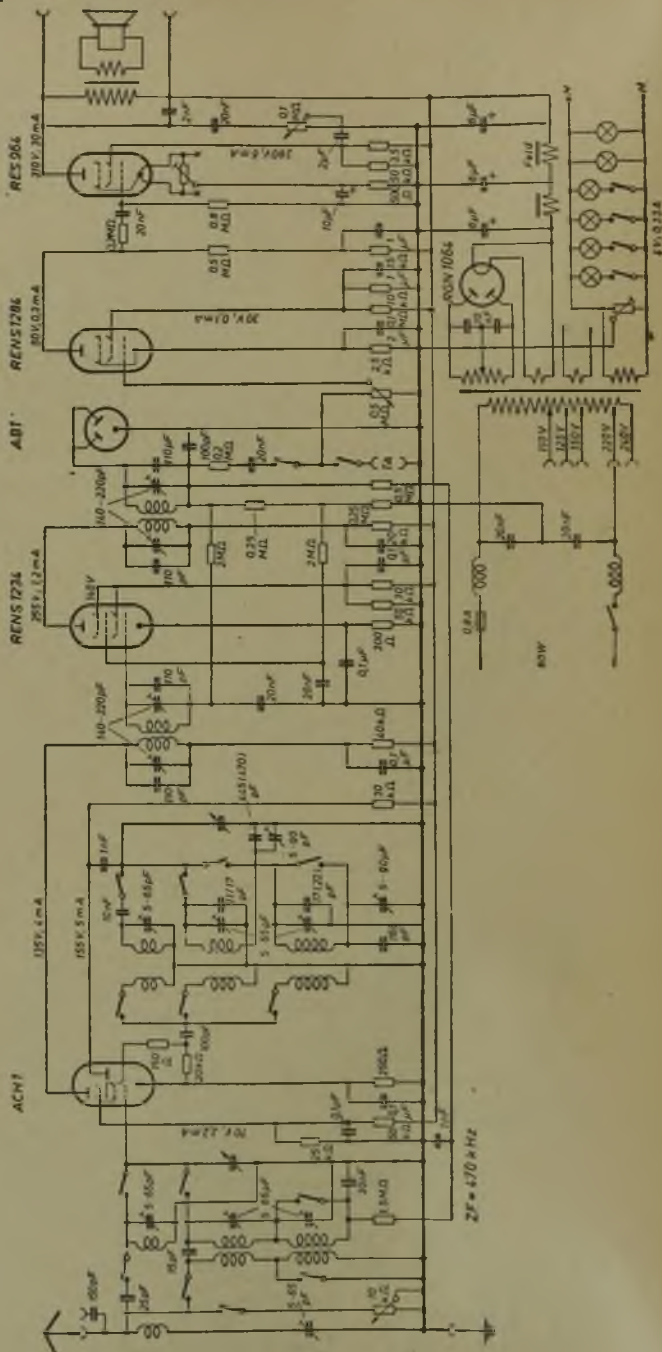

Tefag Supertefadyn W

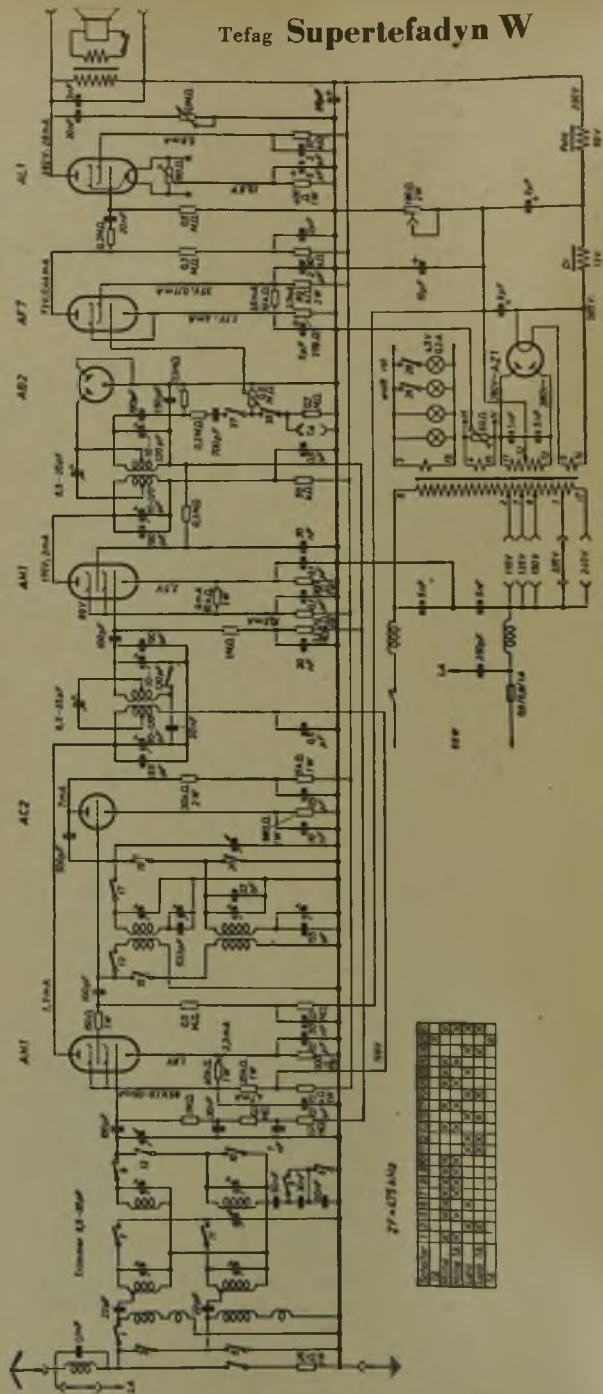

27-475.6-62

1	2	3	4	5	6	7	8	9	10	11	12	13	14	15	16	17	18	19	20	21	22	23	24	25	26	27	28	29	30	31	32	33	34	35	36	37	38	39	40	41	42	43	44	45	46	47	48	49	50	51	52	53	54	55	56	57	58	59	60	61	62	63	64	65	66	67	68	69	70	71	72	73	74	75	76	77	78	79	80	81	82	83	84	85	86	87	88	89	90	91	92	93	94	95	96	97	98	99	100
---	---	---	---	---	---	---	---	---	----	----	----	----	----	----	----	----	----	----	----	----	----	----	----	----	----	----	----	----	----	----	----	----	----	----	----	----	----	----	----	----	----	----	----	----	----	----	----	----	----	----	----	----	----	----	----	----	----	----	----	----	----	----	----	----	----	----	----	----	----	----	----	----	----	----	----	----	----	----	----	----	----	----	----	----	----	----	----	----	----	----	----	----	----	----	----	----	----	----	-----

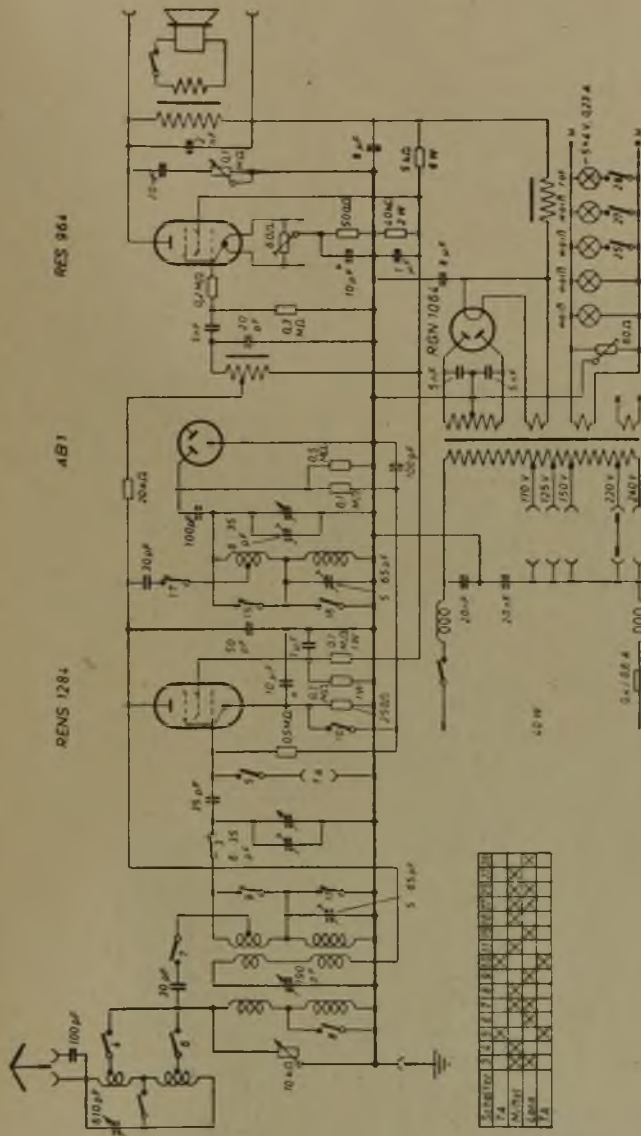

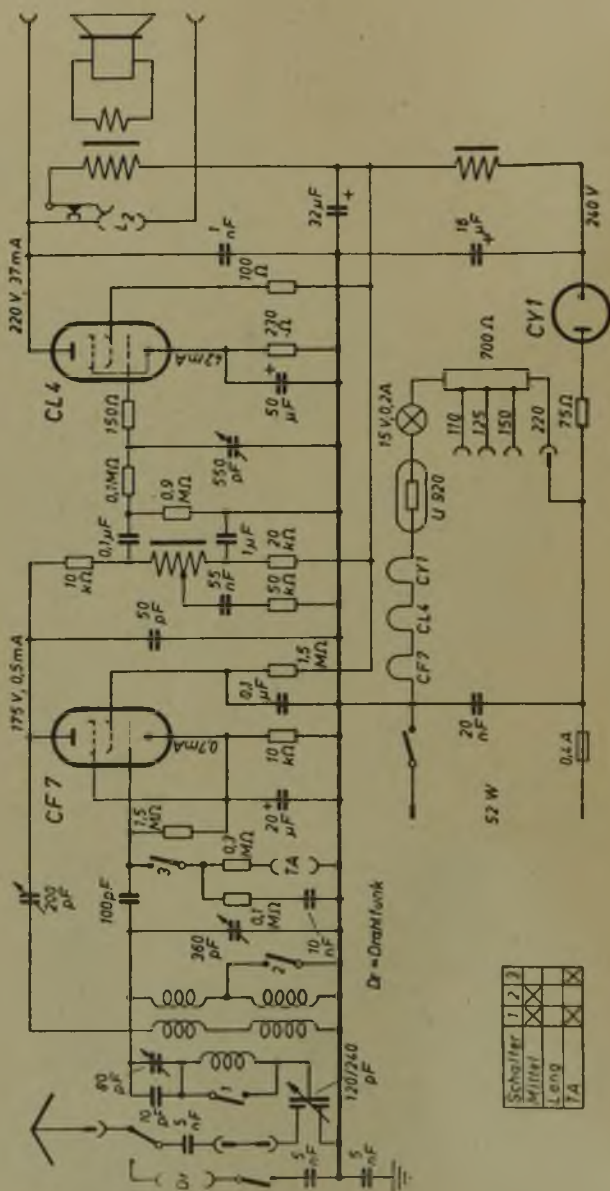

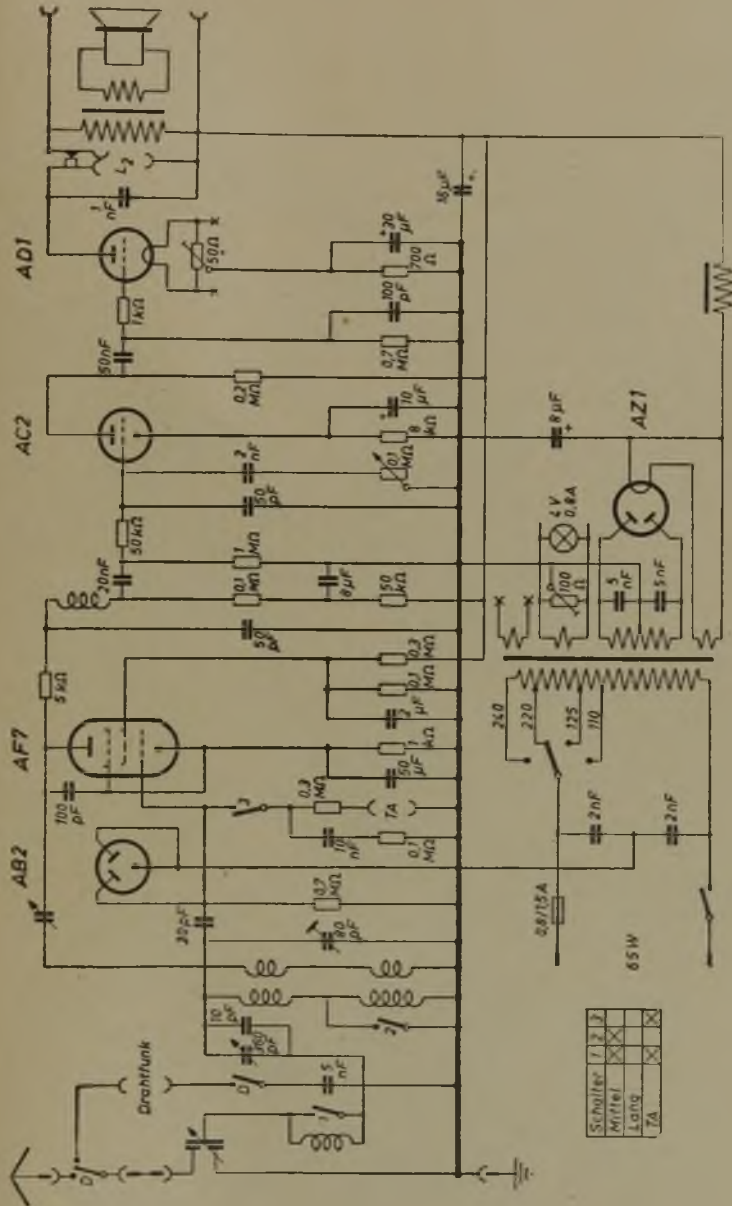

Tefag Tefadyn 150 A (Ausführung I und II)

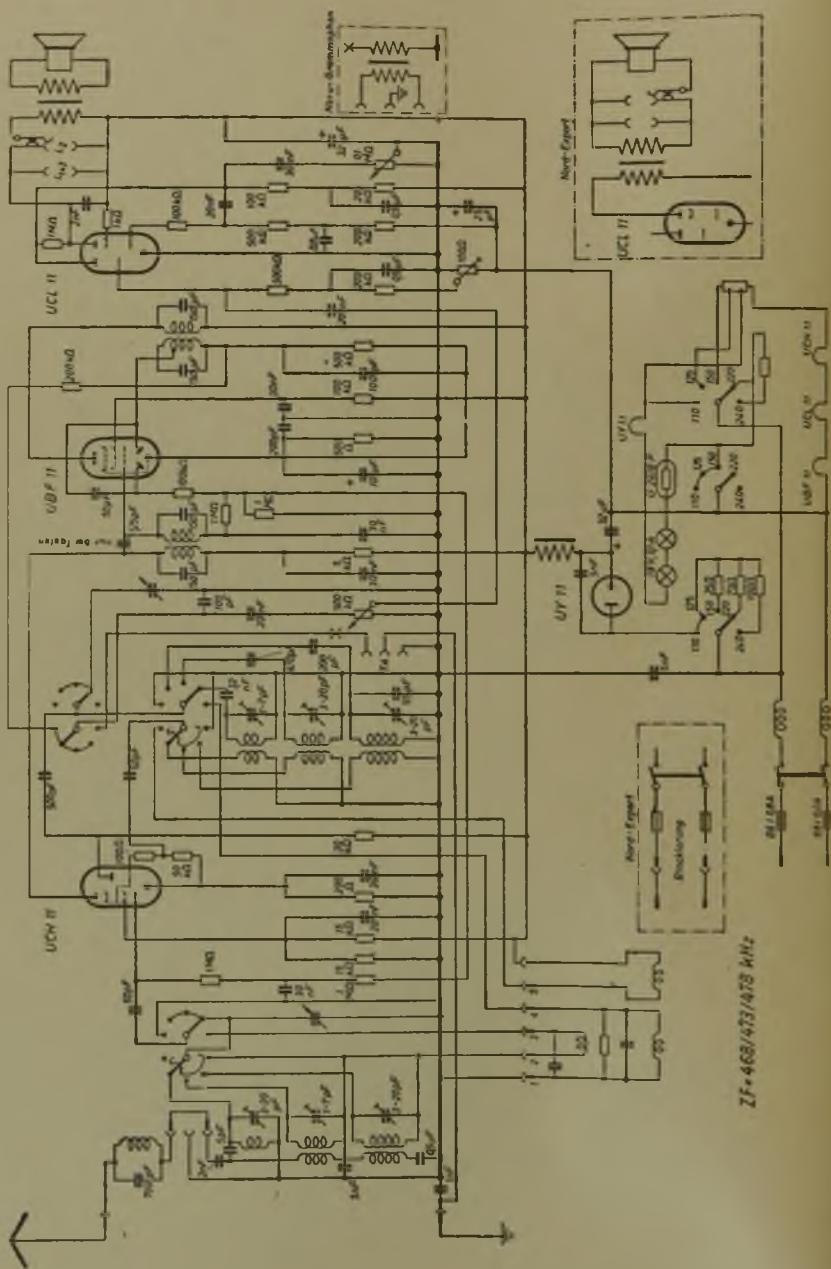

ZF = 468/473/478 kHz

Tefag Tefadyn 150 W (Ausführung I-IV)

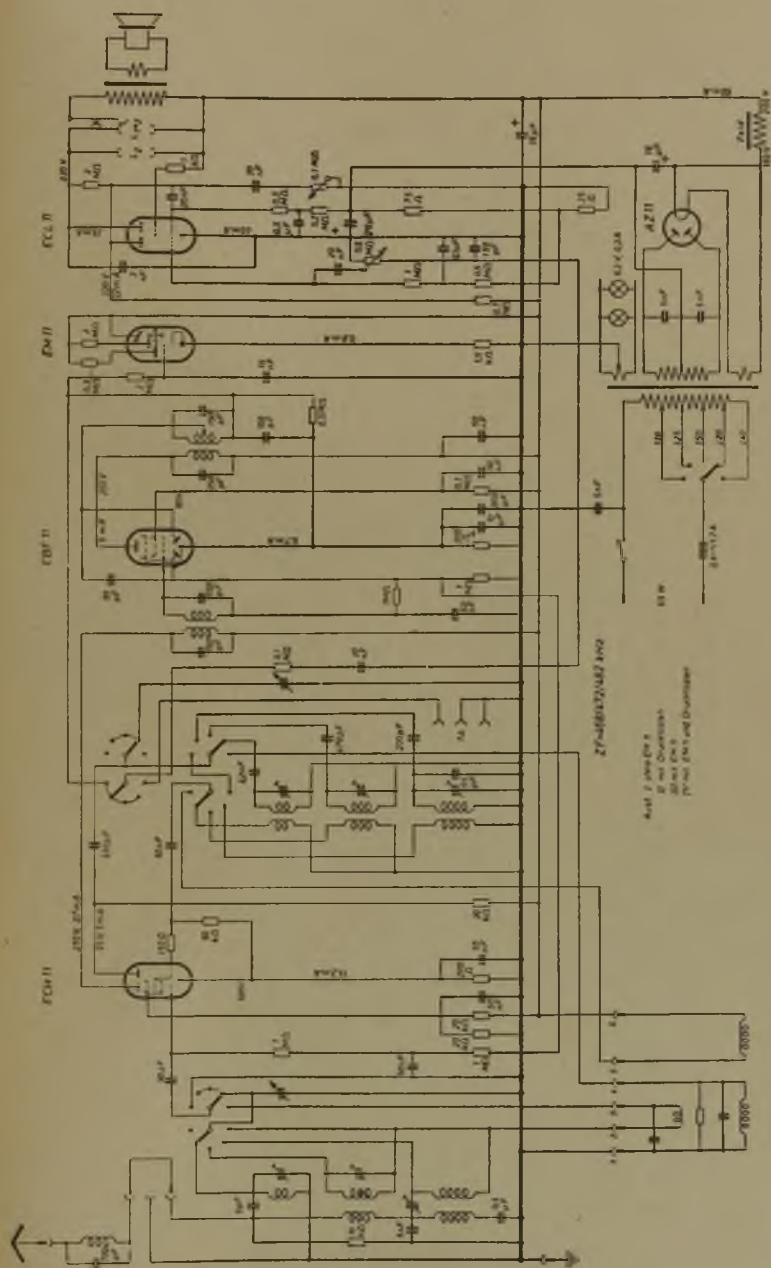

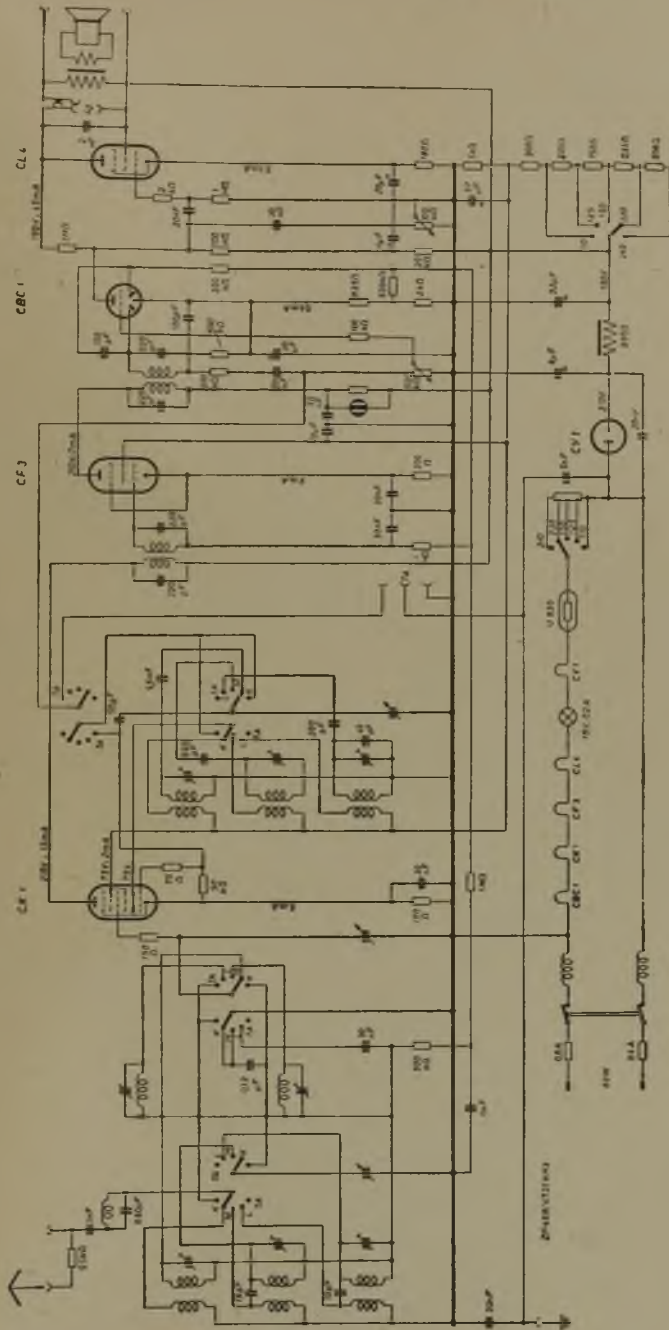

Tefag Tefadyn 200 W

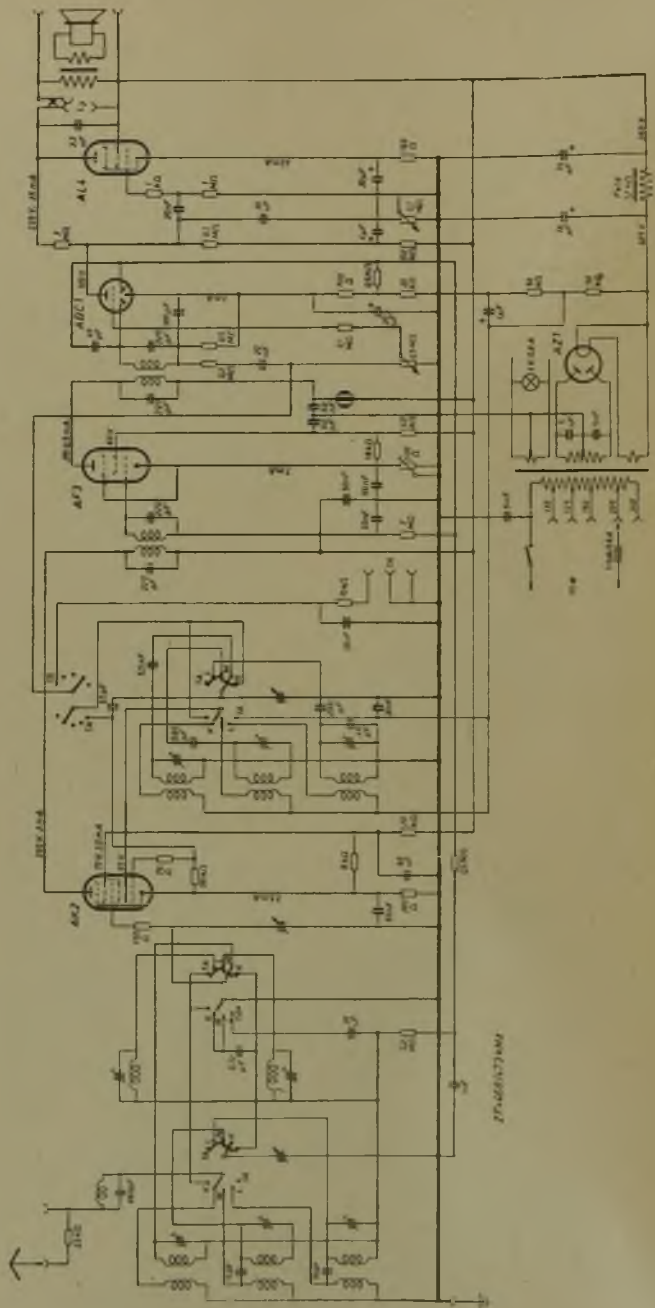

Tefag Tefadyn 200 / 38 GW

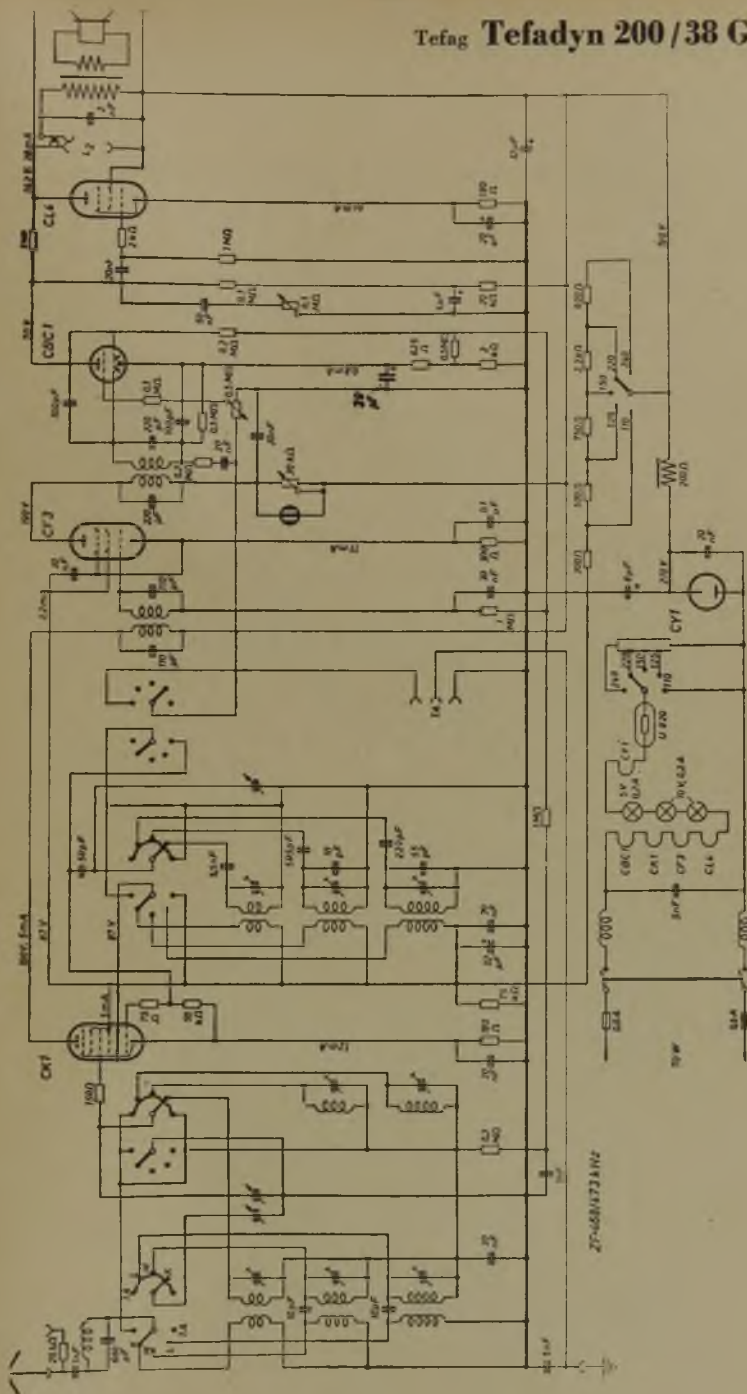

Tefag **Tefadyn 200 / 38 W**

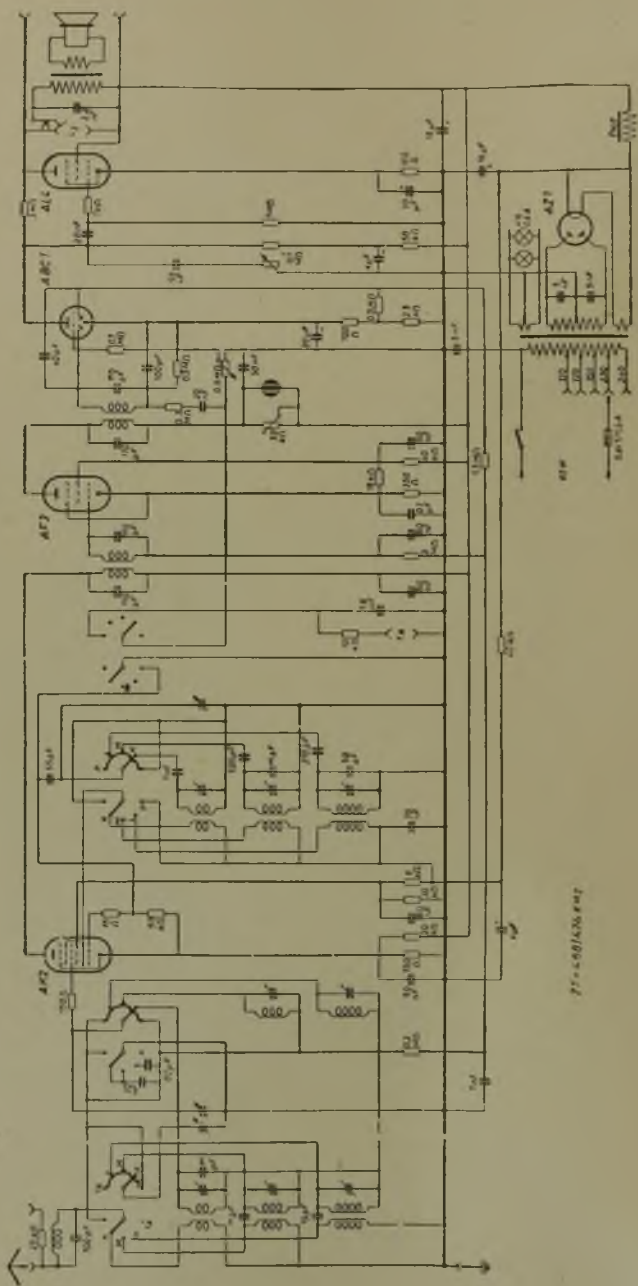

Tefag Tefadyn 268 W

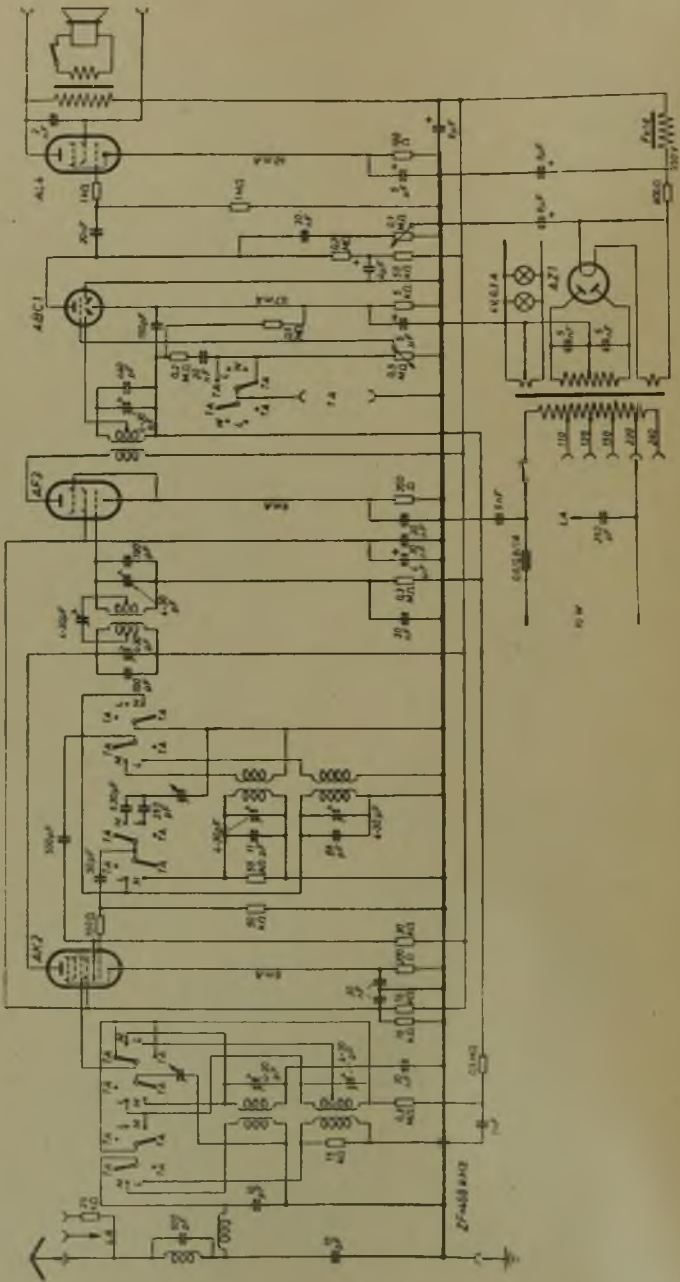

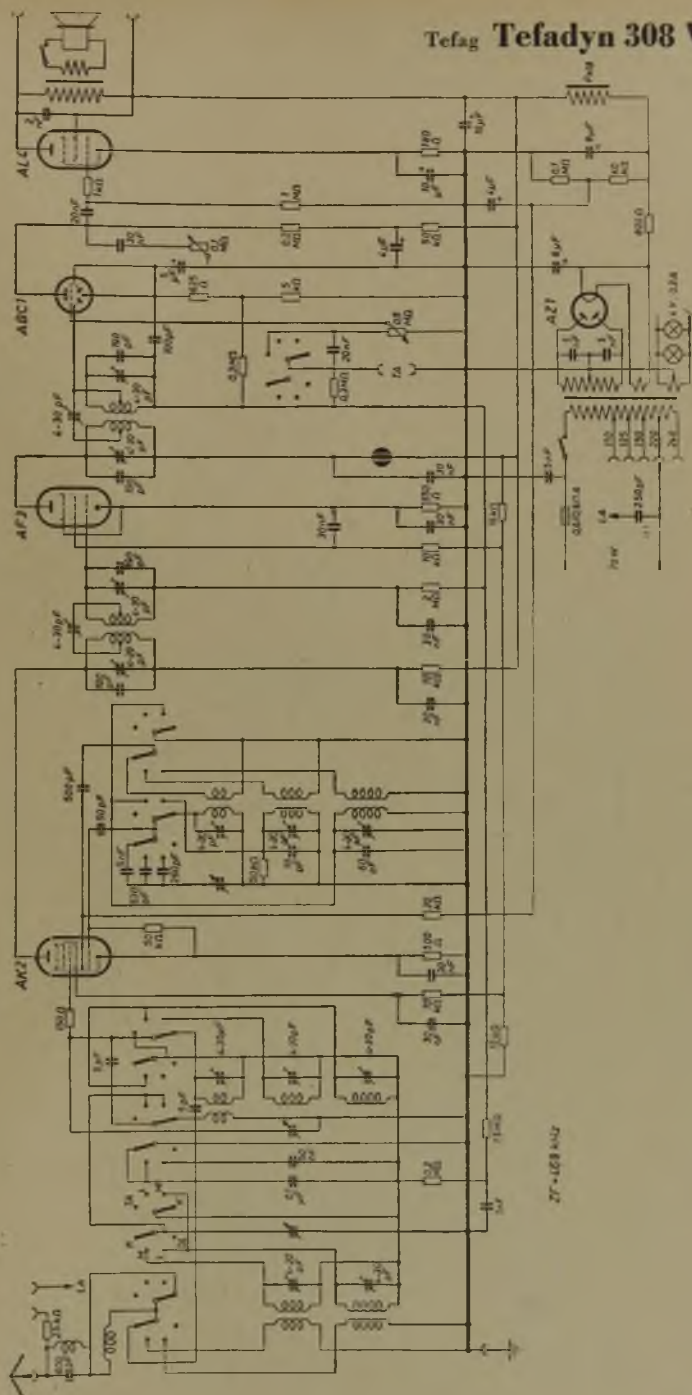

Tefag **Tefadyn 338 GW**
 (linke Seite des Schaltbildes)

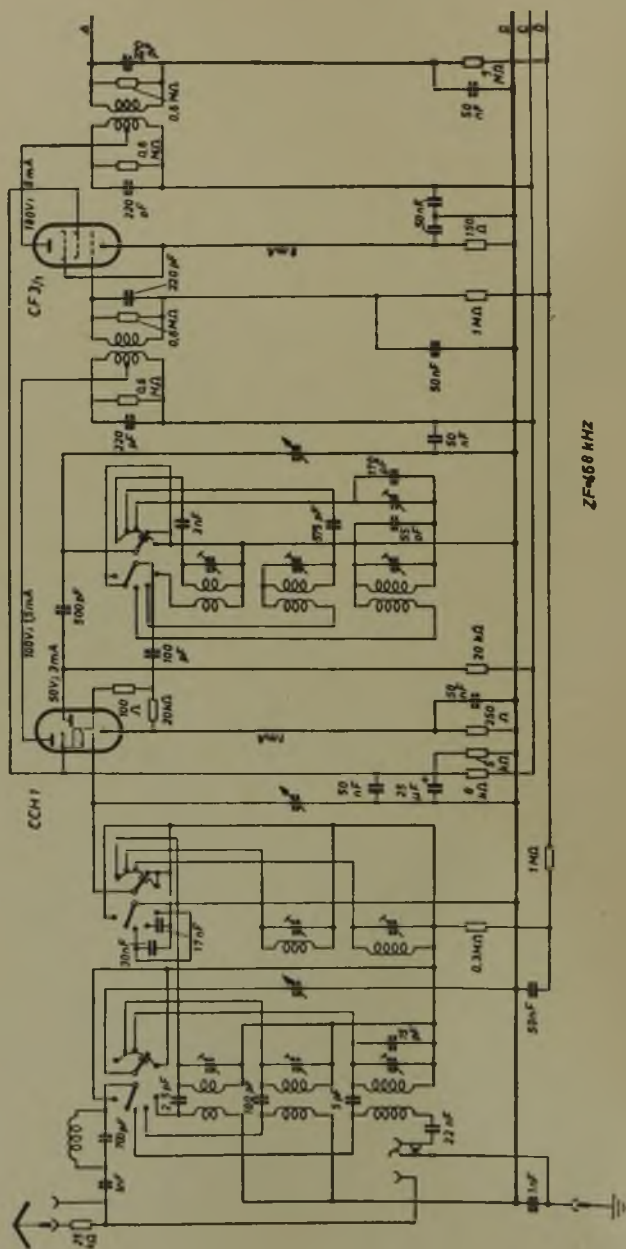

Tefag Tefadyn 338 W

(linke Seite des Schaltbildes)

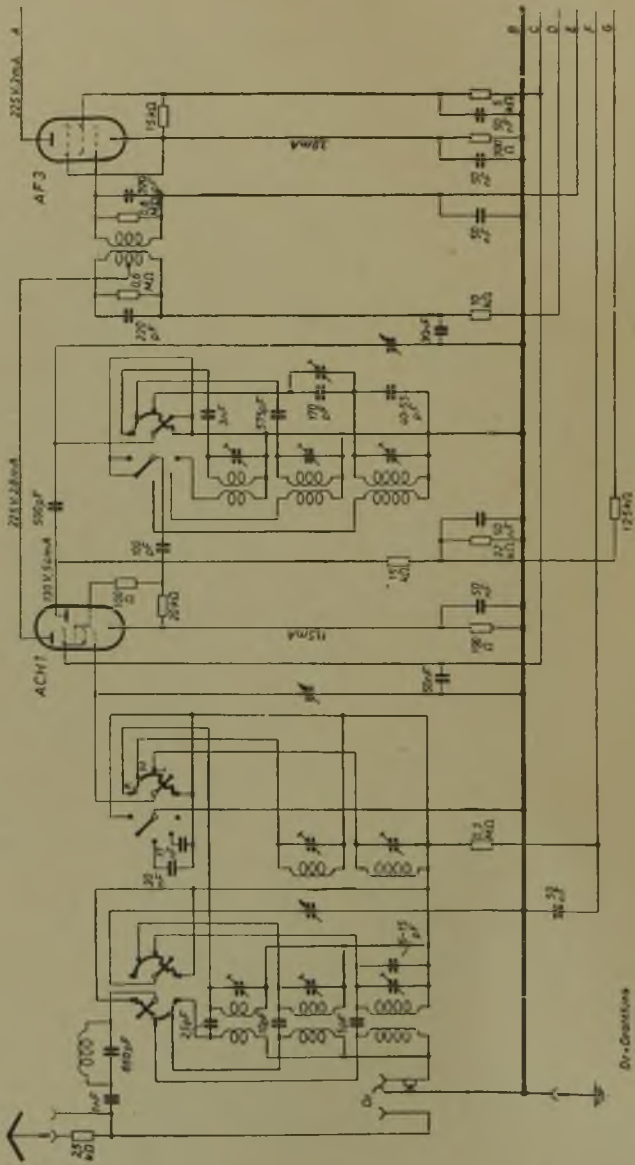

Tefag **Tefdyn 338 W**
 (rechte Seite des Schaltbildes)

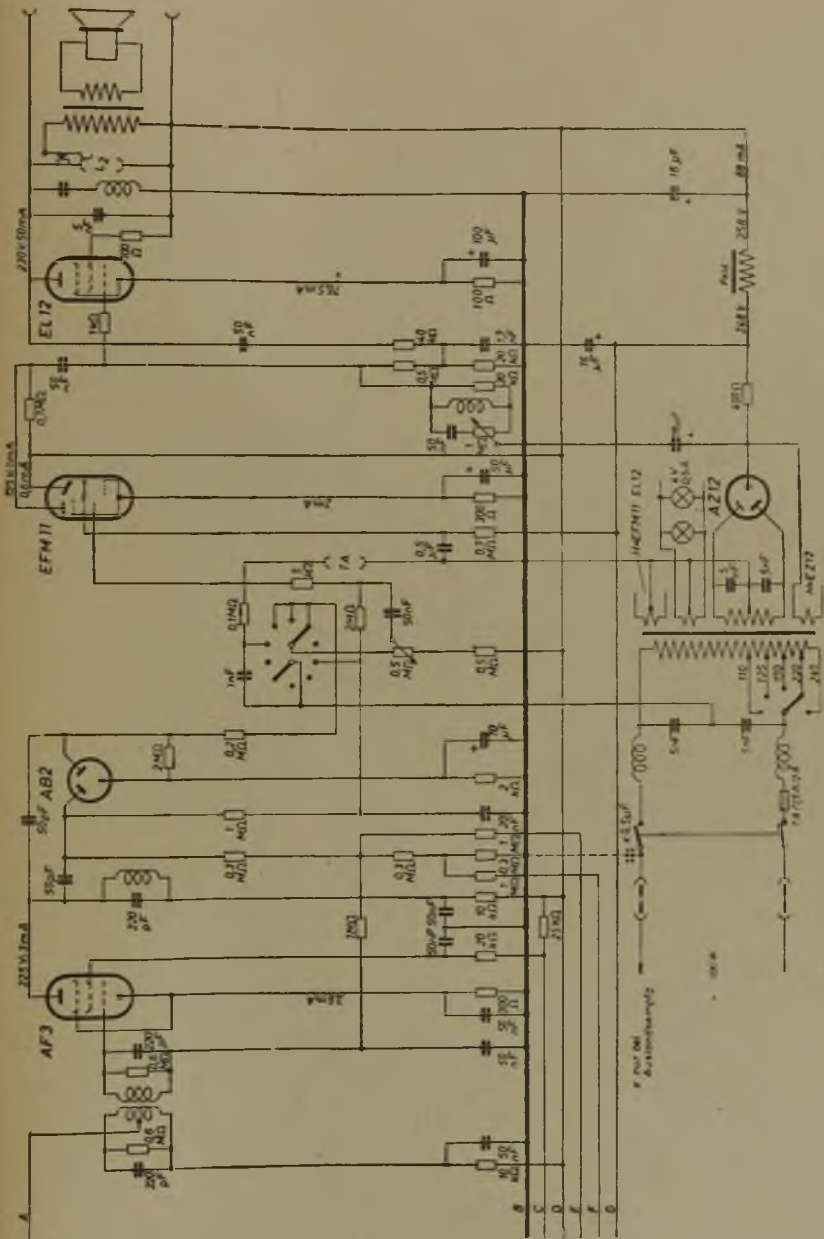

Tefag **Tefadyn 340 W und 8 W 35**
 (linke Seite des Schaltbildes)

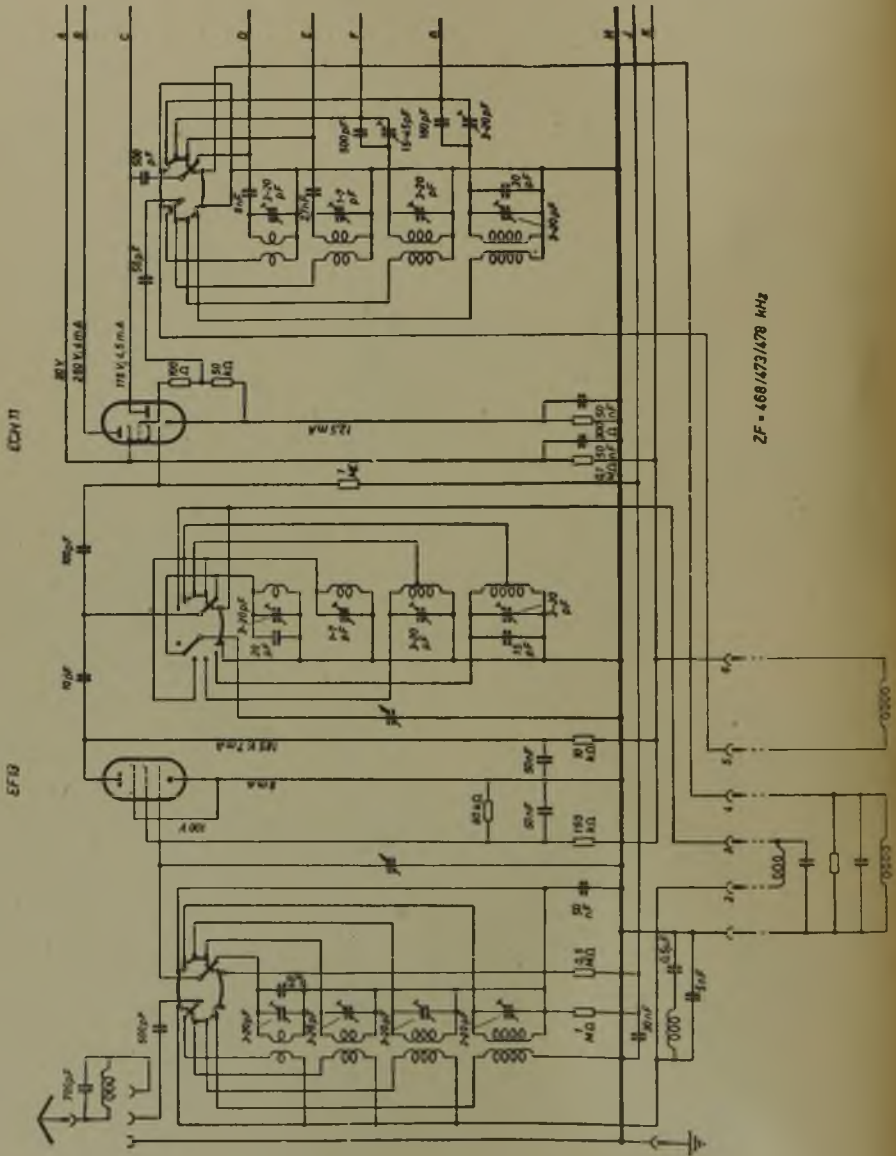

2F = 468 / 473 / 478 MHz

Tefag Tefadyn 340 W und 8 W 35

(rechte Seite des Schaltbildes)

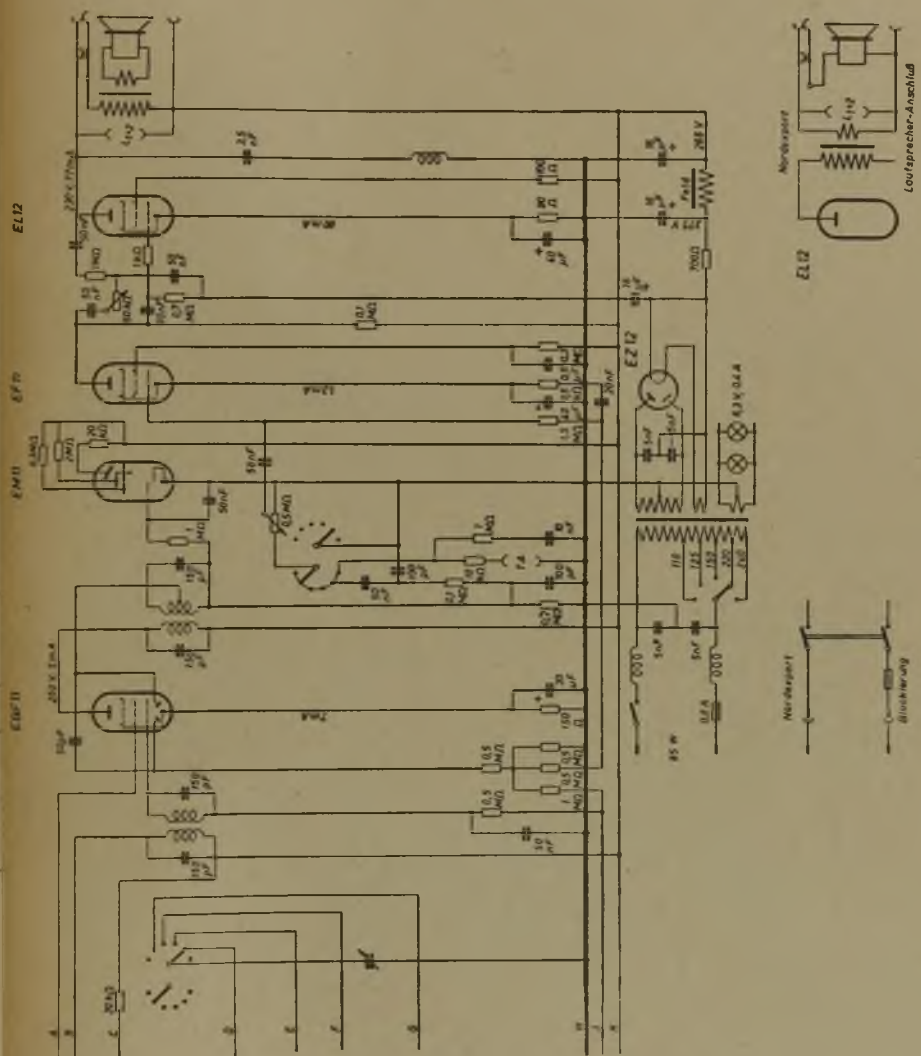

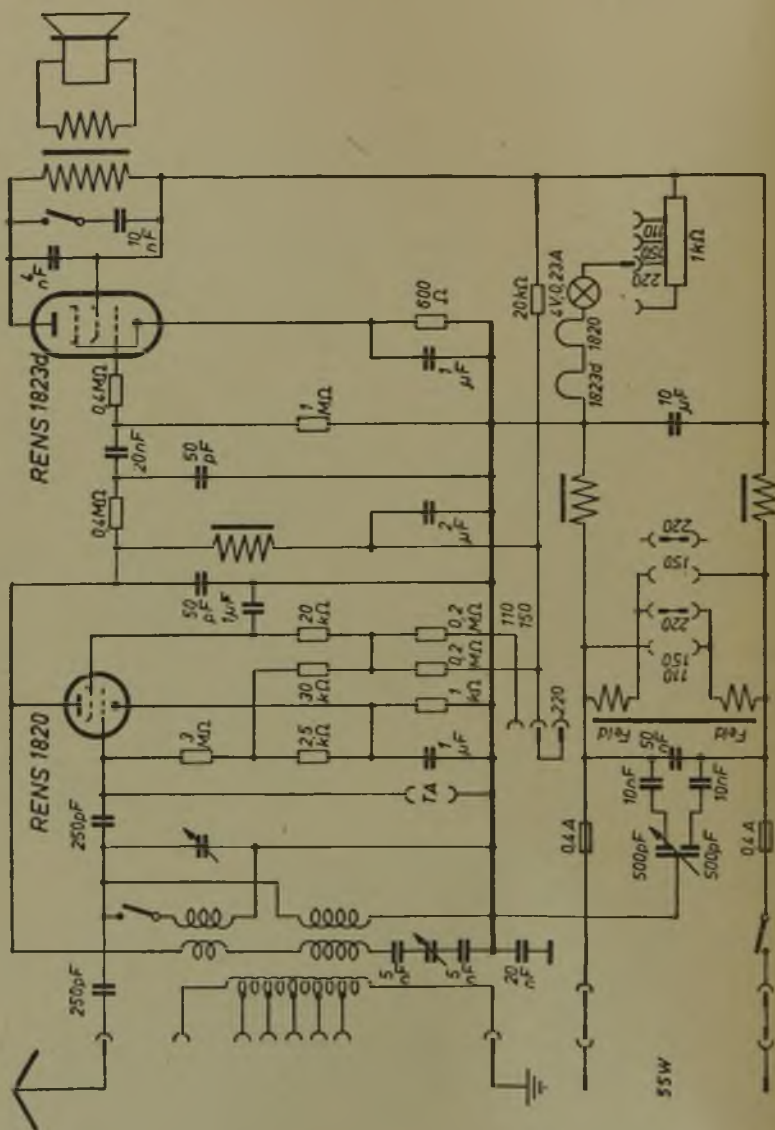

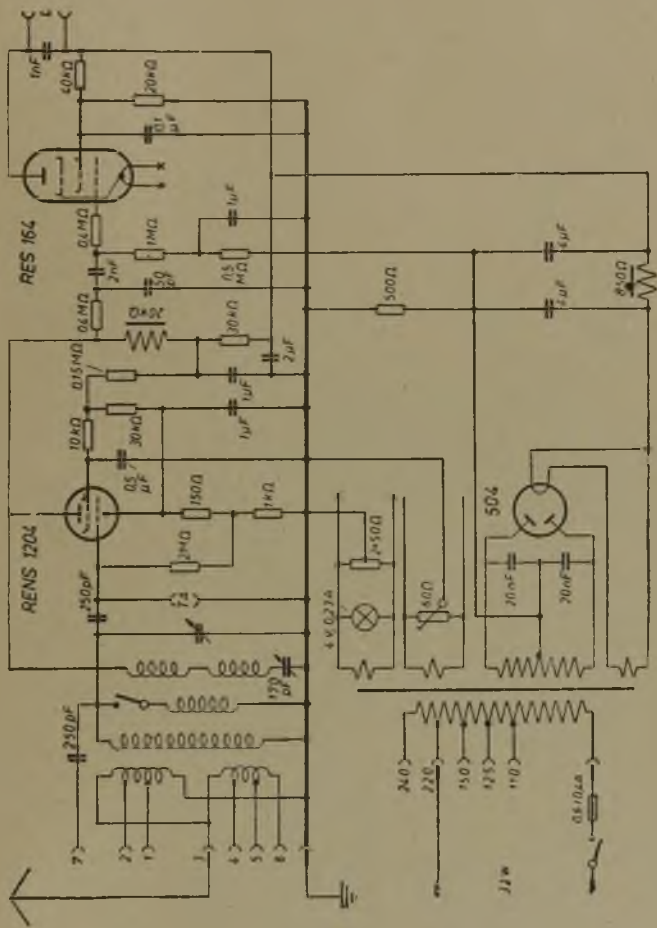

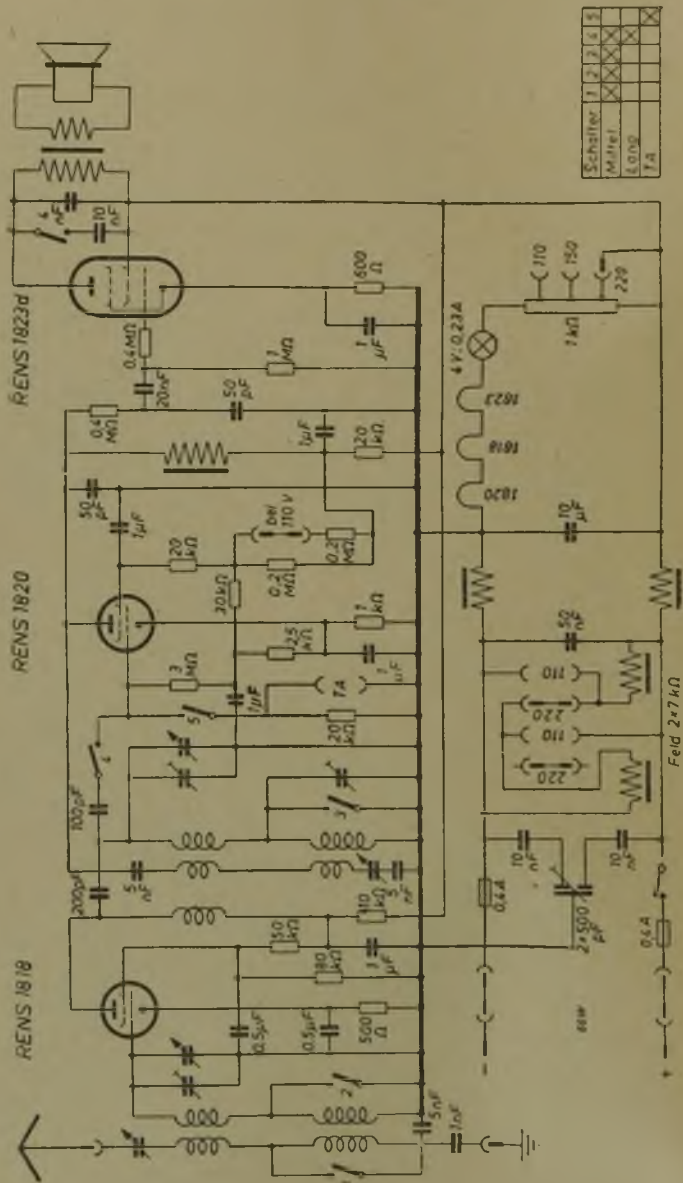

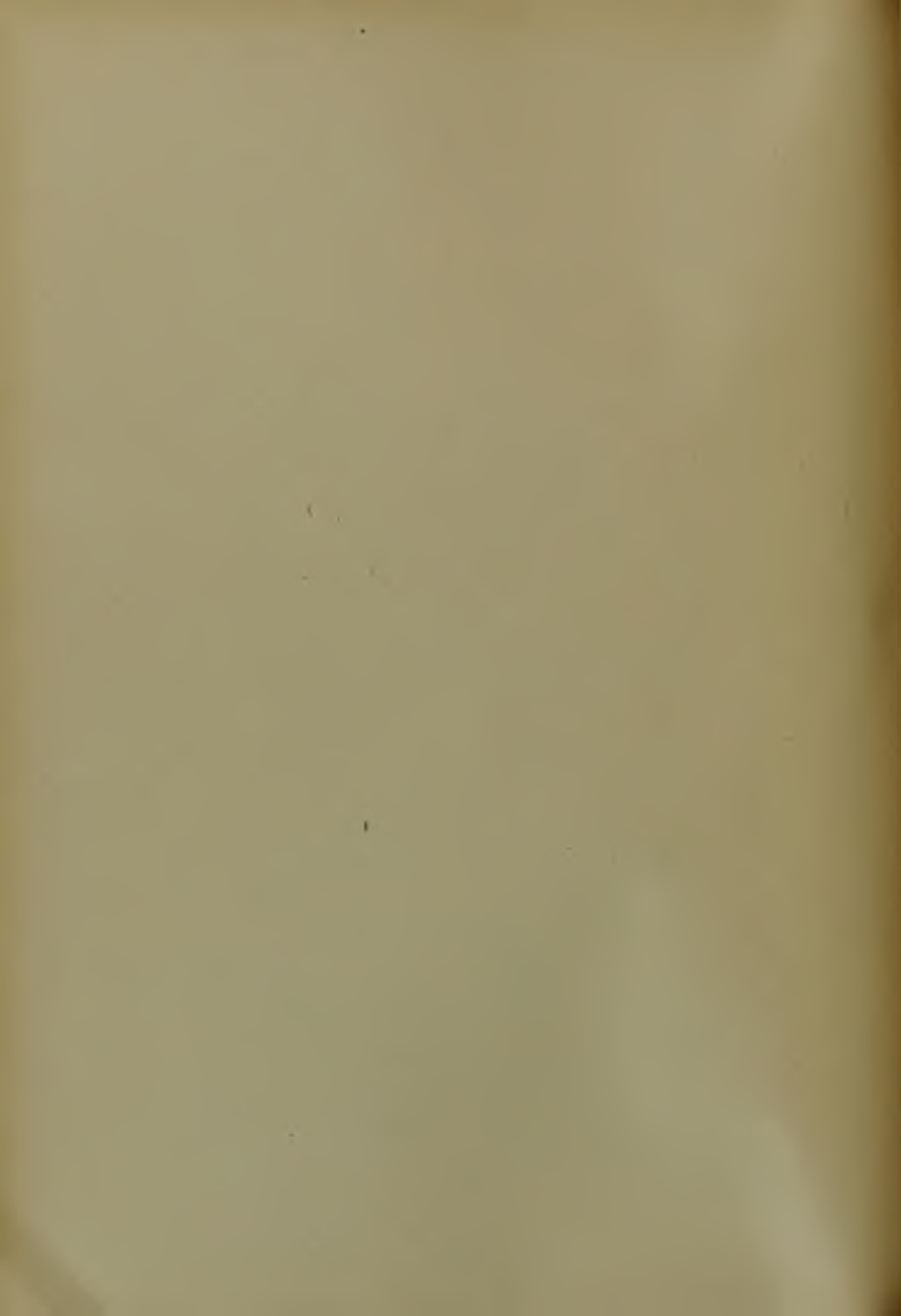

TEFI



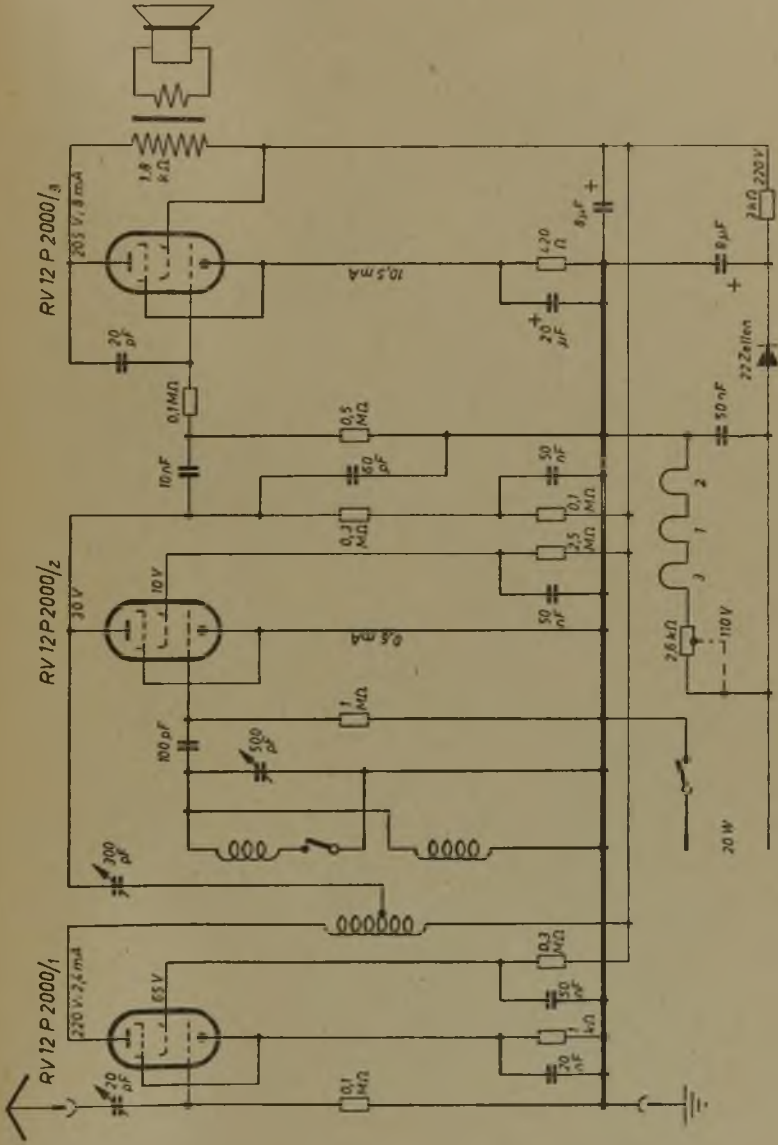

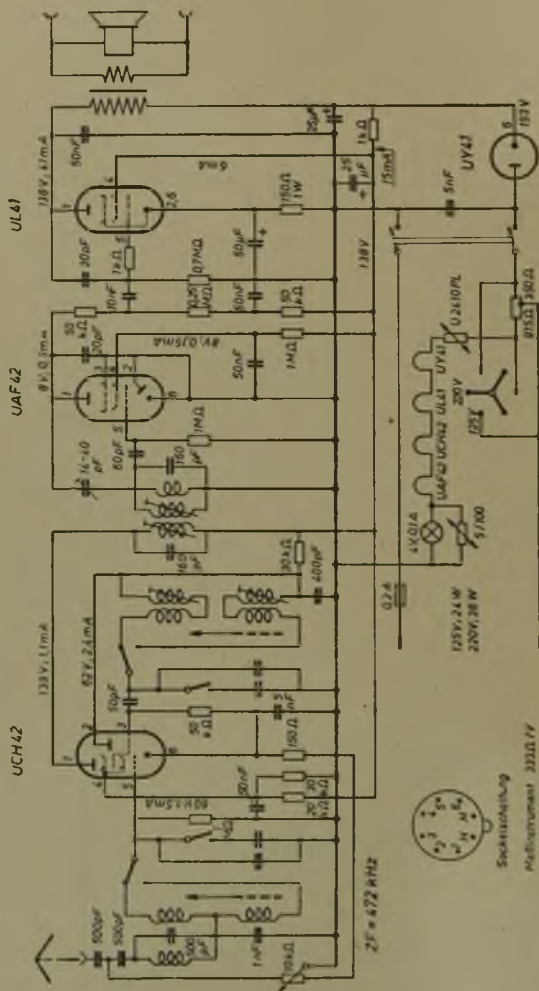

Socketauslegung
 Multimeter 3312 IV
 Betrieb 100V

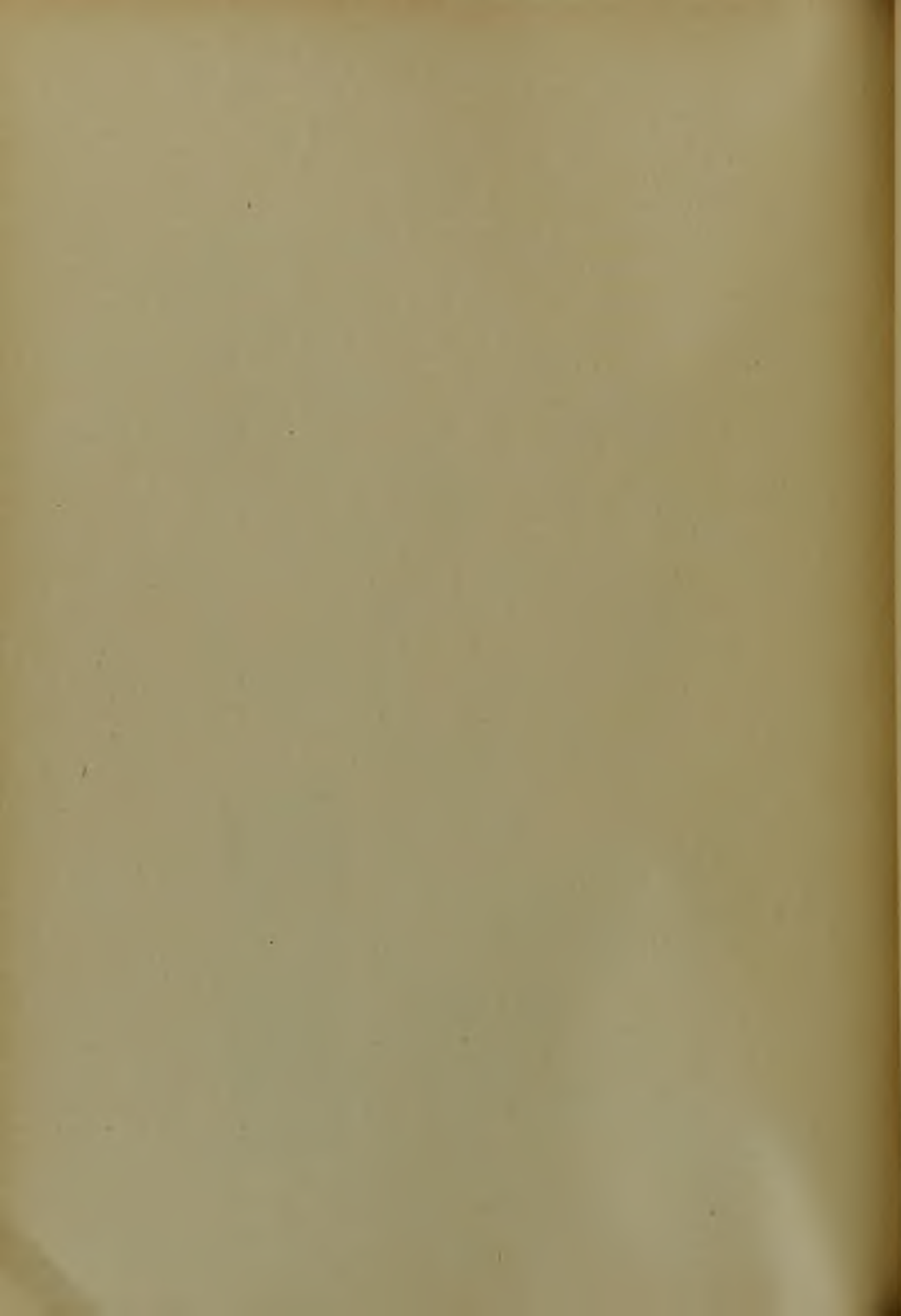

TEKADE

(Produktion nach 1945)



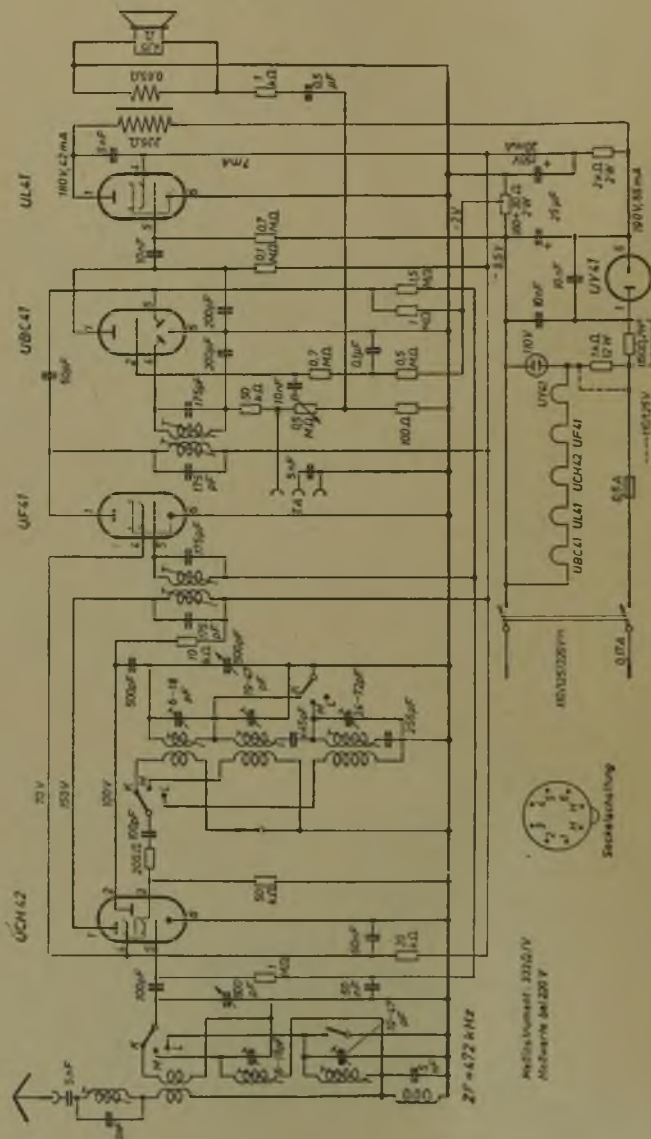

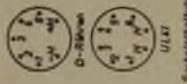
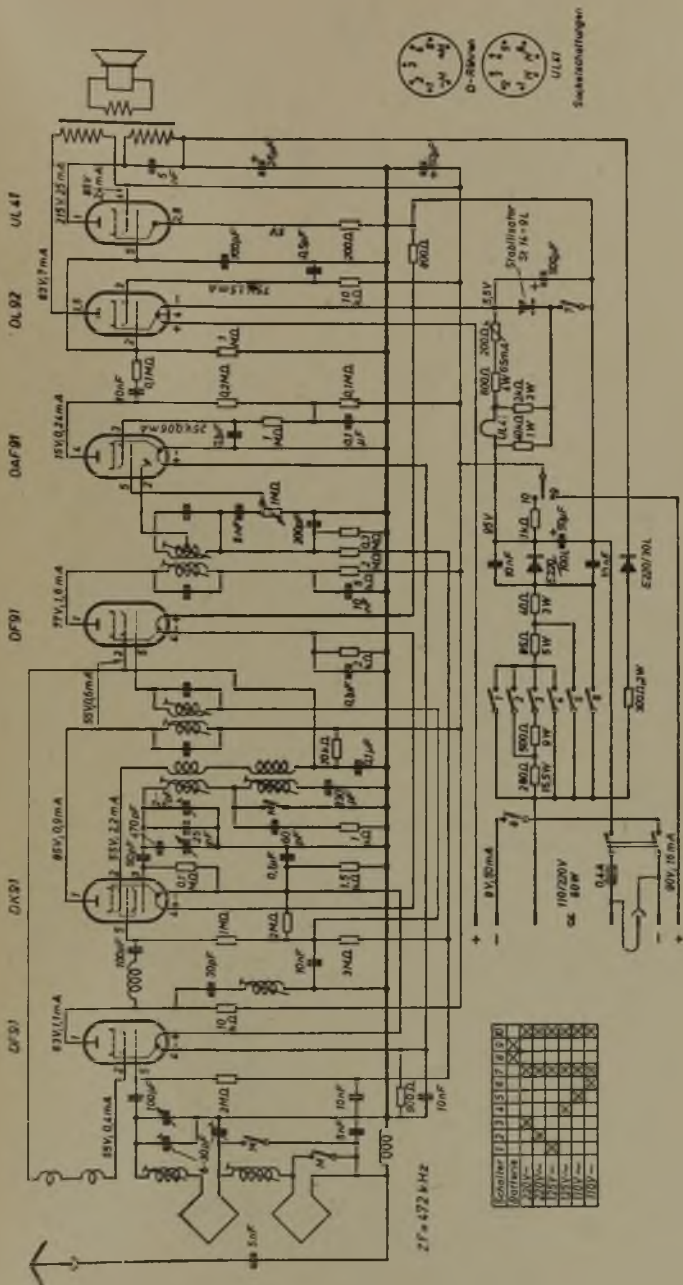

Schalter	1	2	3	4	5	6	7	8	9	0
Batterie	1	2	3	4	5	6	7	8	9	0
250V	1	2	3	4	5	6	7	8	9	0
110V	1	2	3	4	5	6	7	8	9	0
80V	1	2	3	4	5	6	7	8	9	0
10V	1	2	3	4	5	6	7	8	9	0
0V	1	2	3	4	5	6	7	8	9	0

TEKADE WK 50 Edelklang

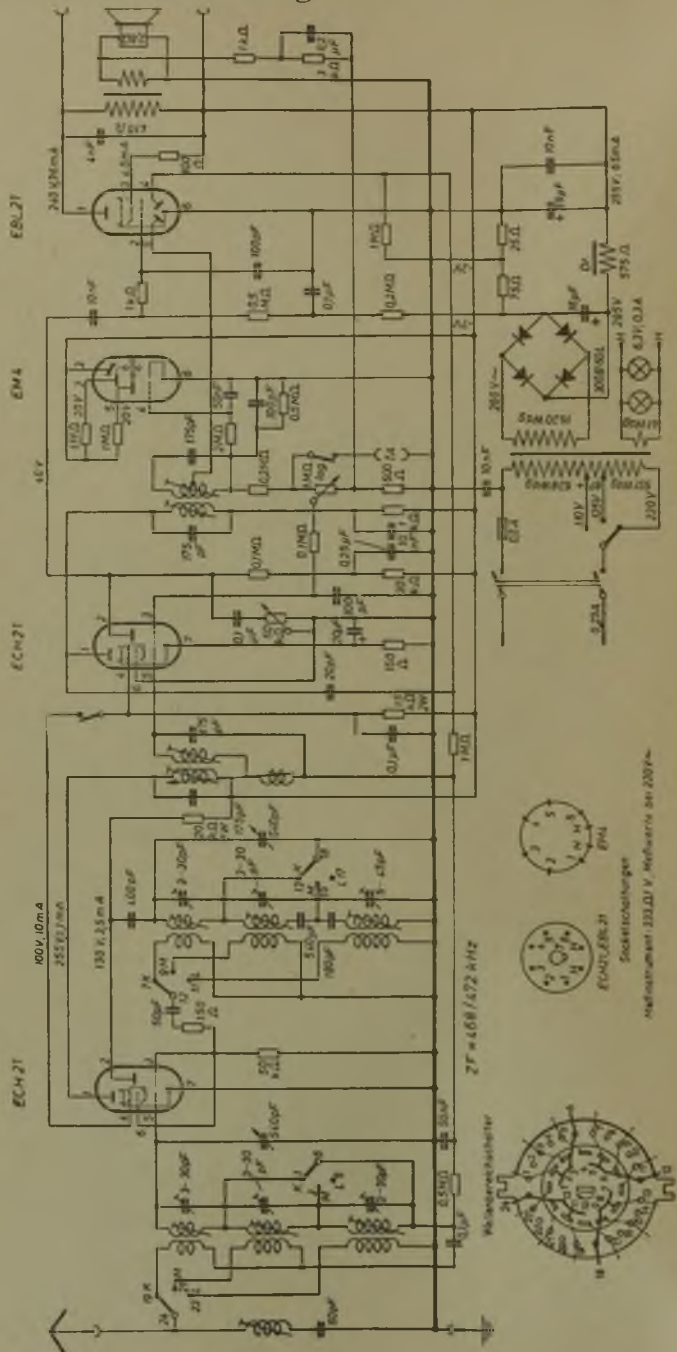

Maßstab: 1:100, V. Maßstab der 200V

TRIADE GWK 50 Edelklang

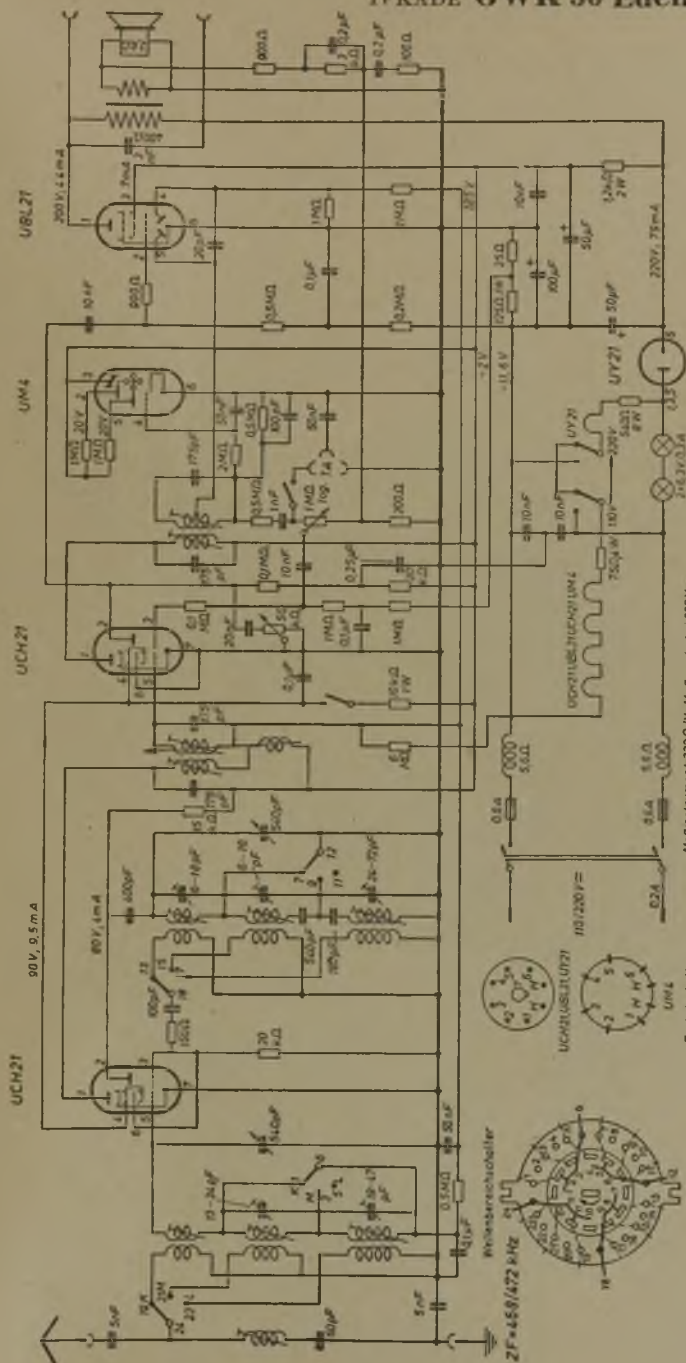

Medinstrument 333Ω/V, Maßwert bei 200V

Steckschaltungen

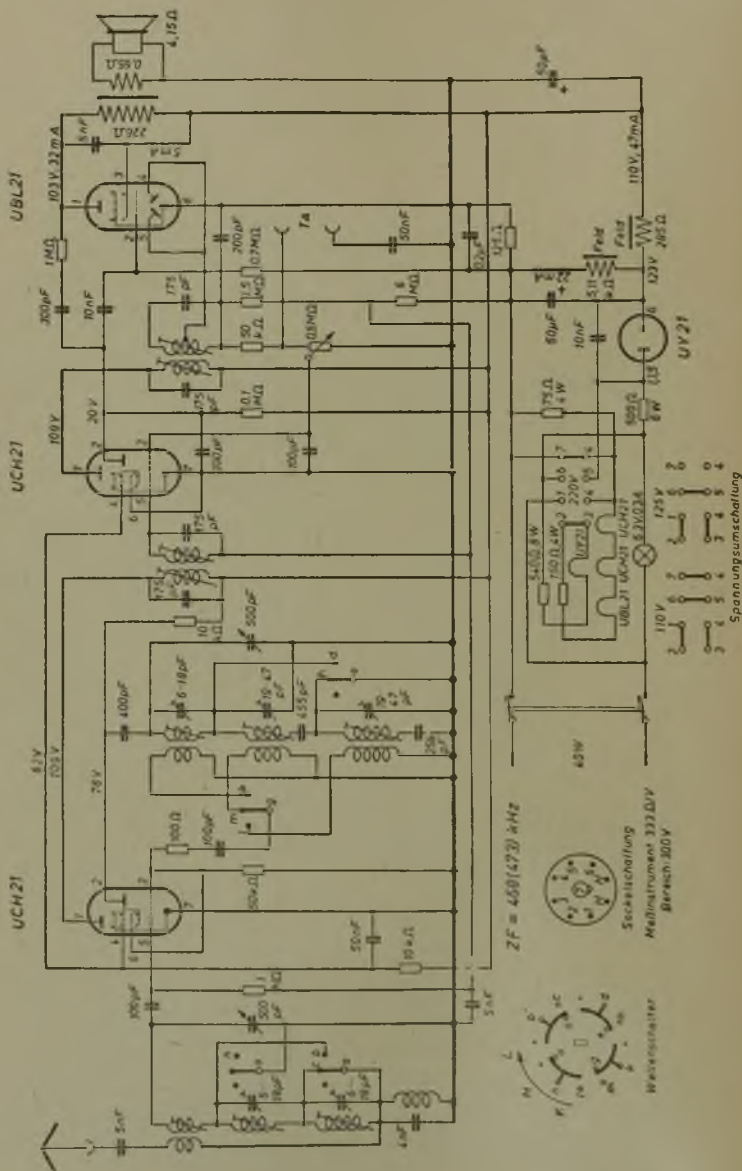

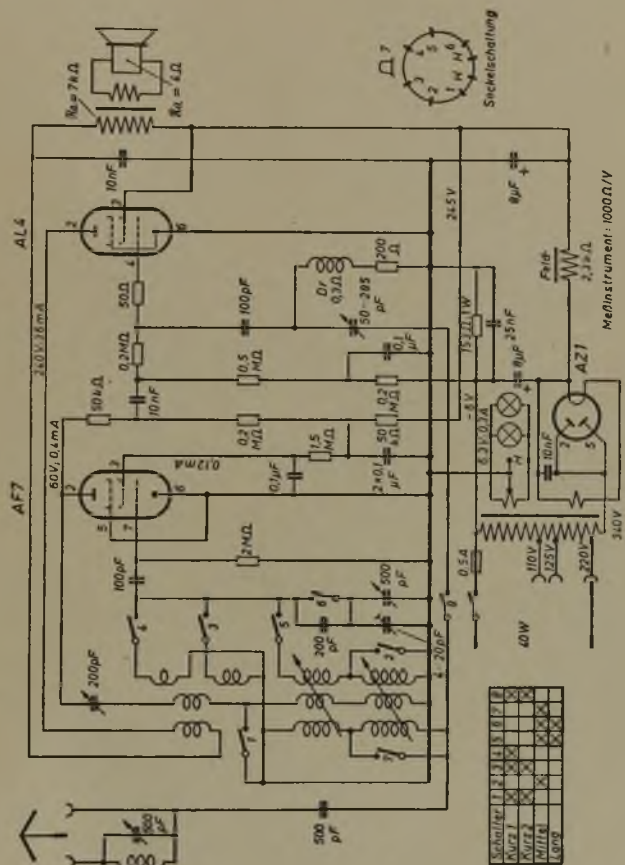

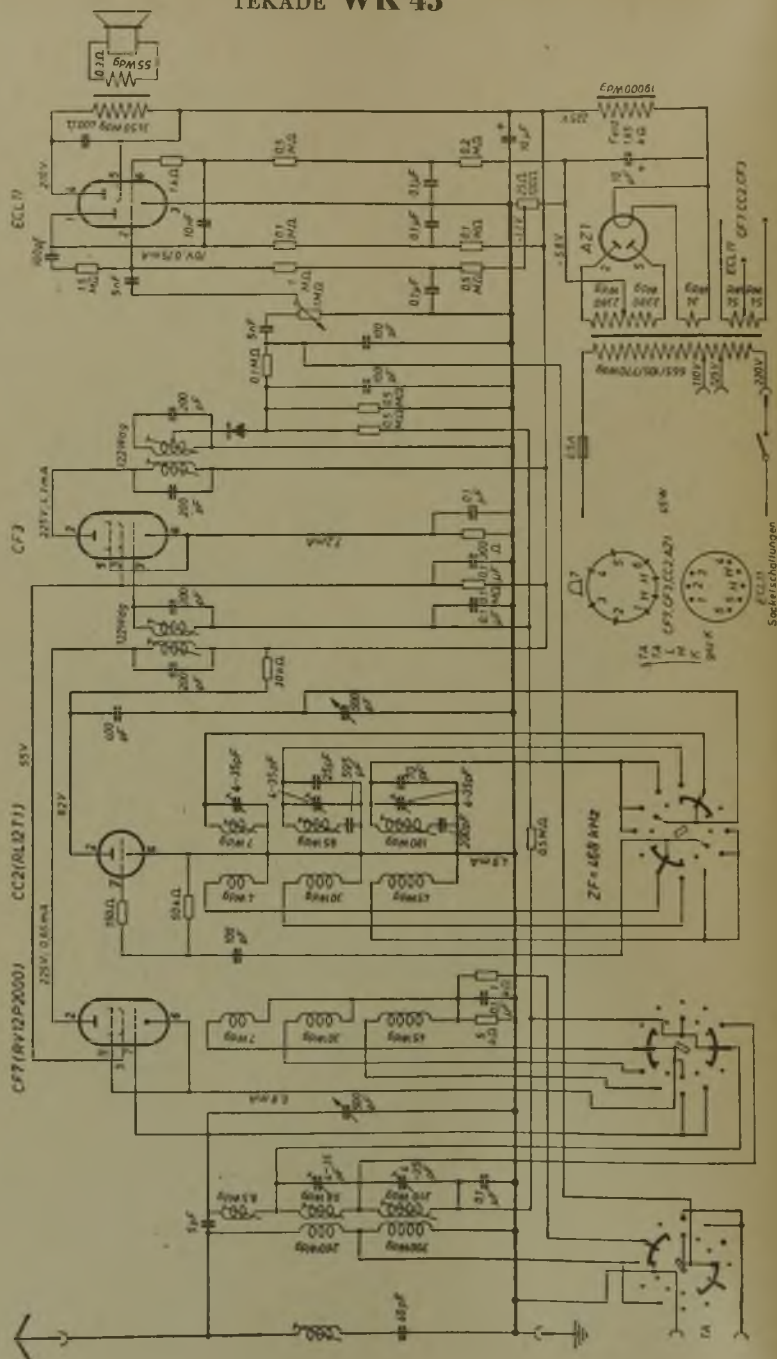

Sacherschaltungen

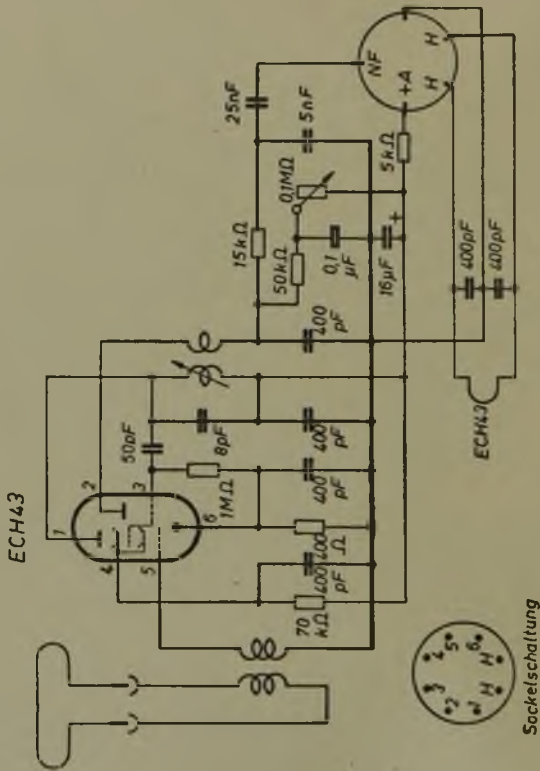

Sockelschaltung

TEKADE
(Produktion vor 1945)



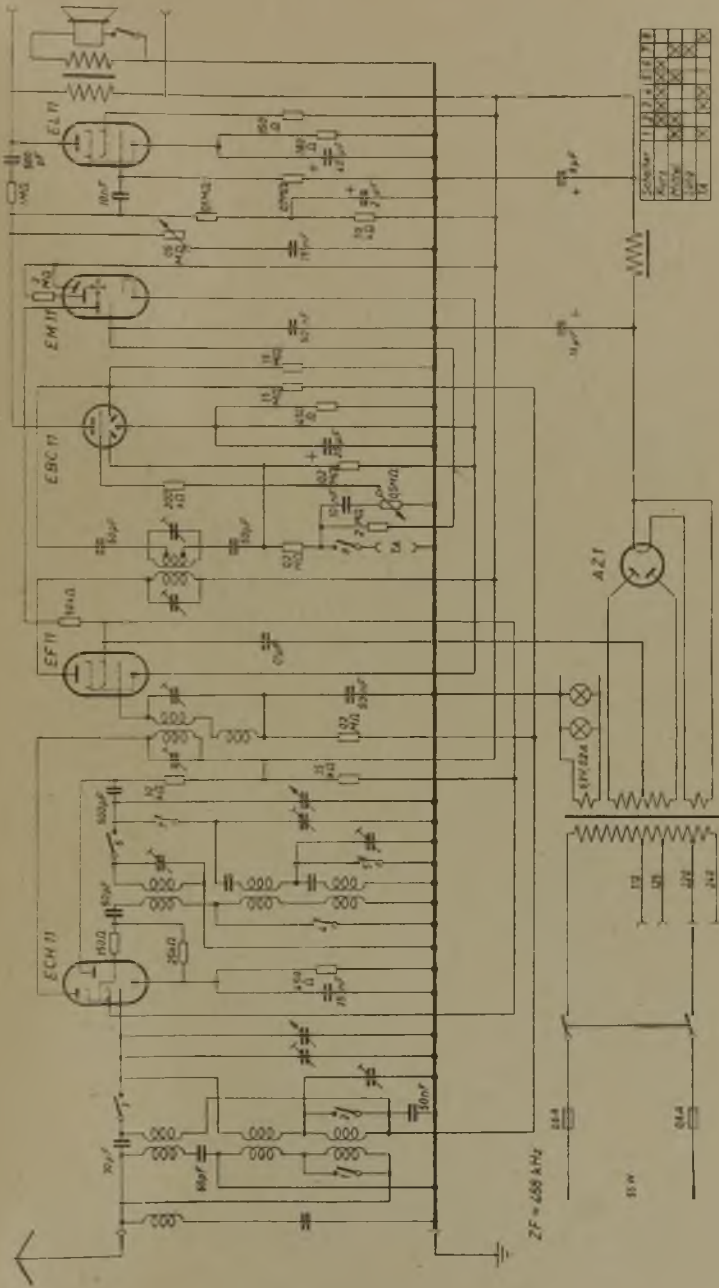

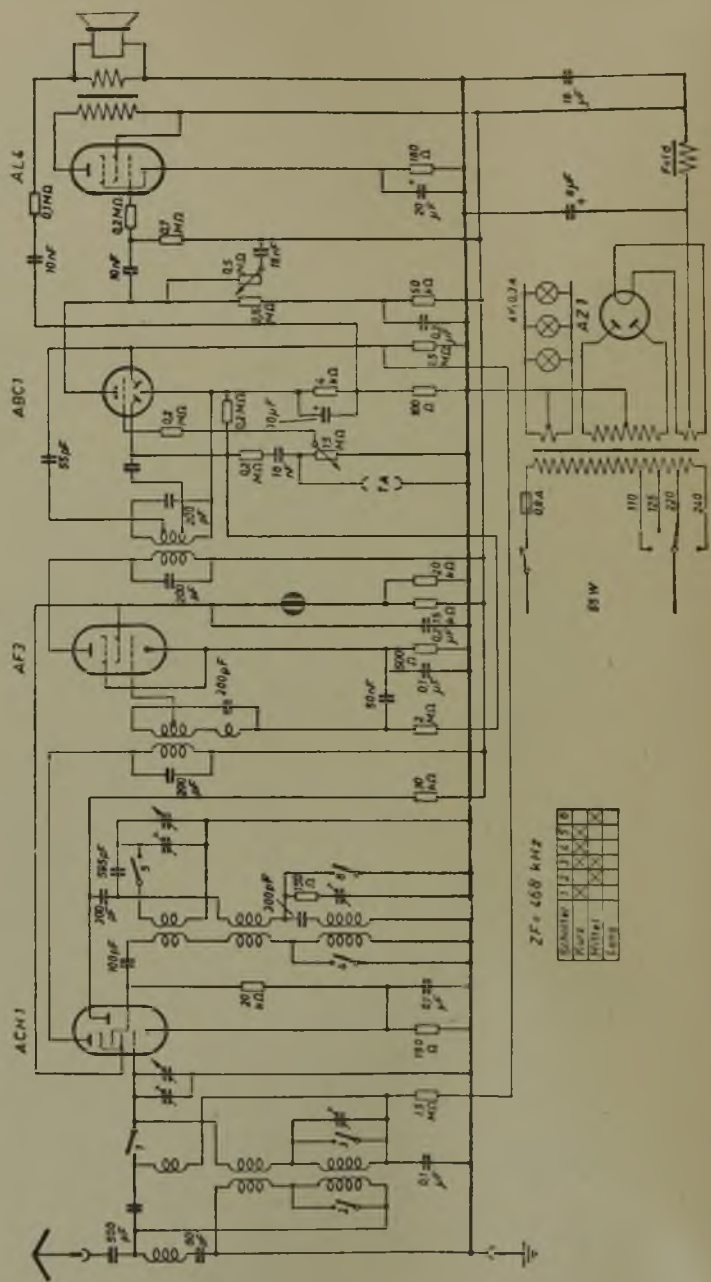

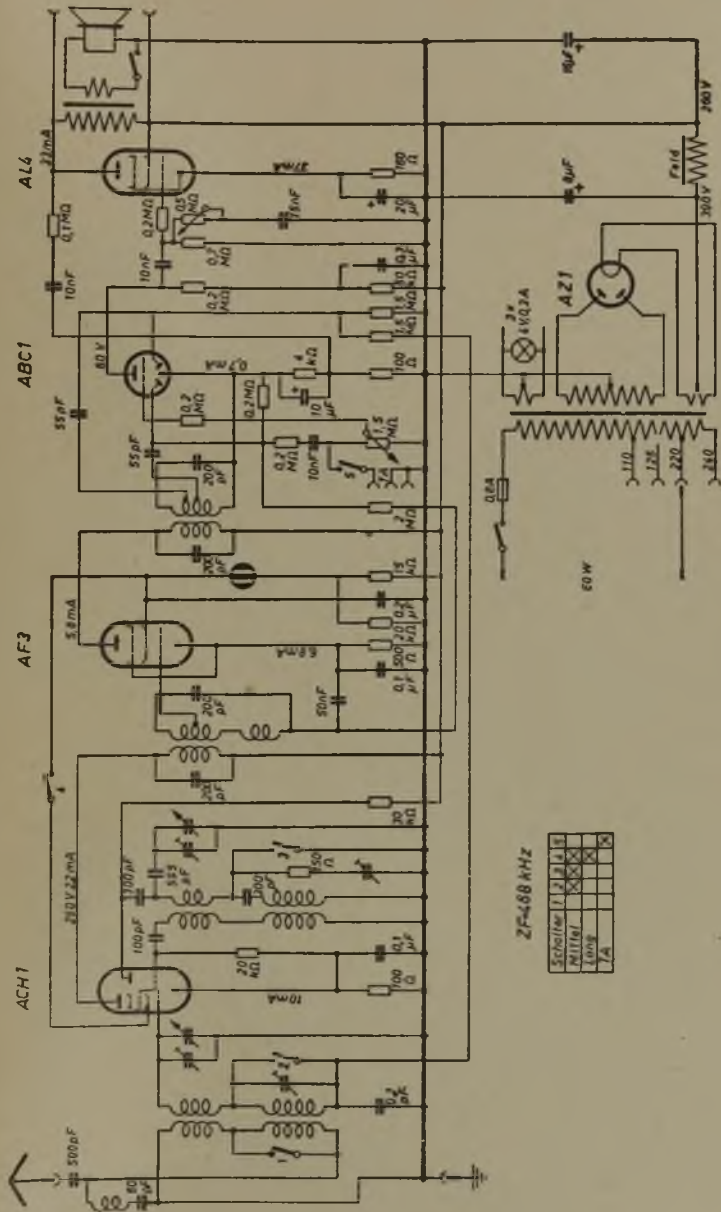

ZF=458 kHz

Schaltwe	1	2	3	4	5
MITTEL	✓	✓	✓	✓	✓
Obwe					
U					

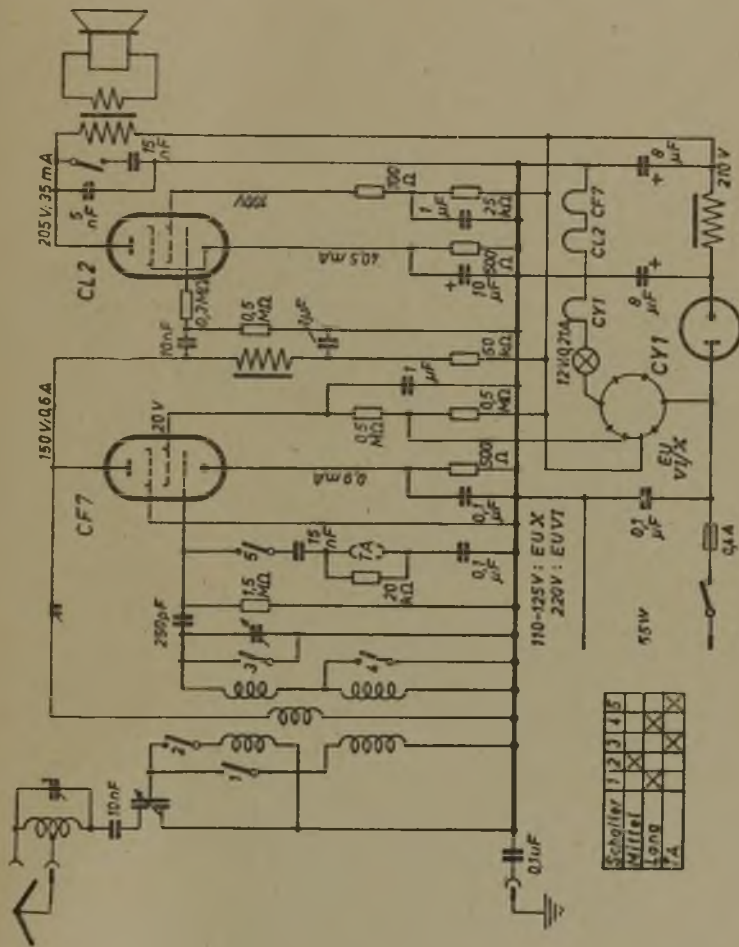

TEKADE Diplomat G

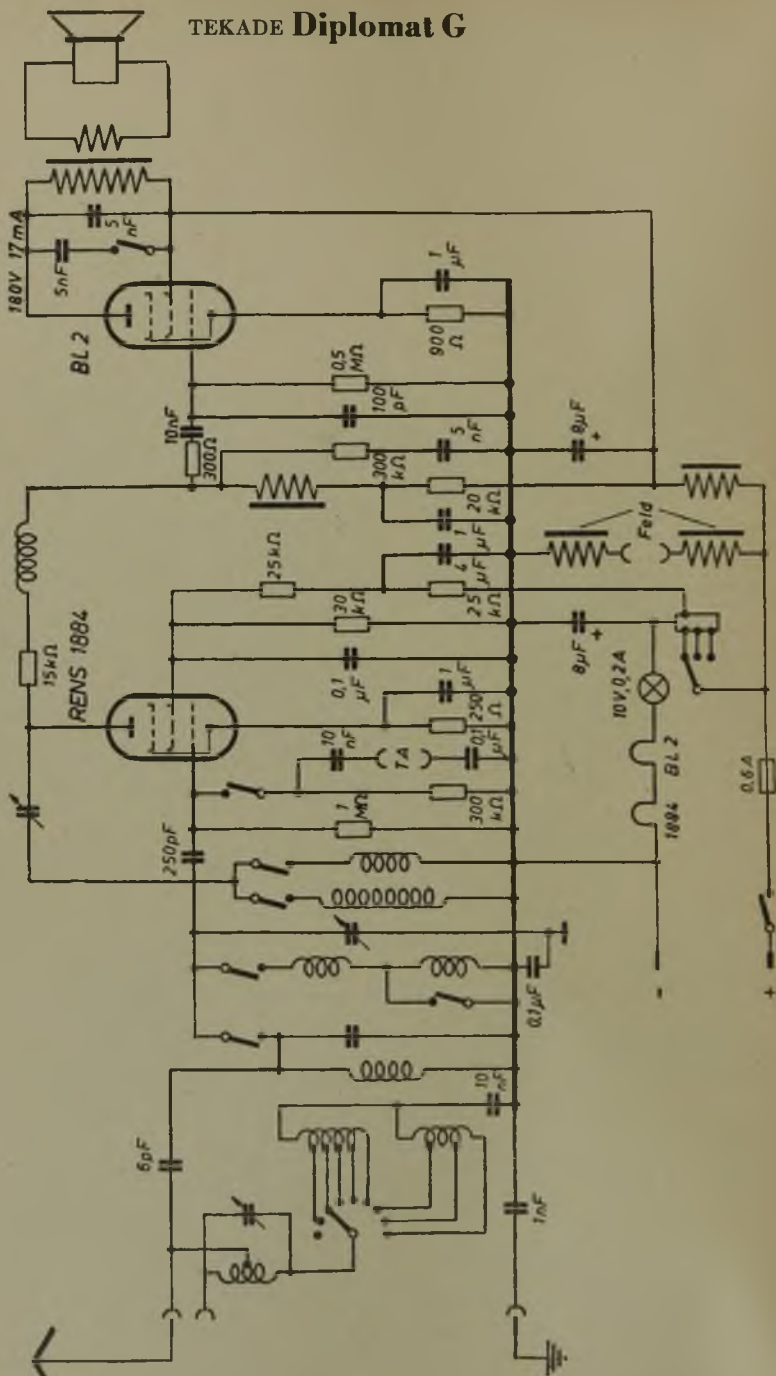

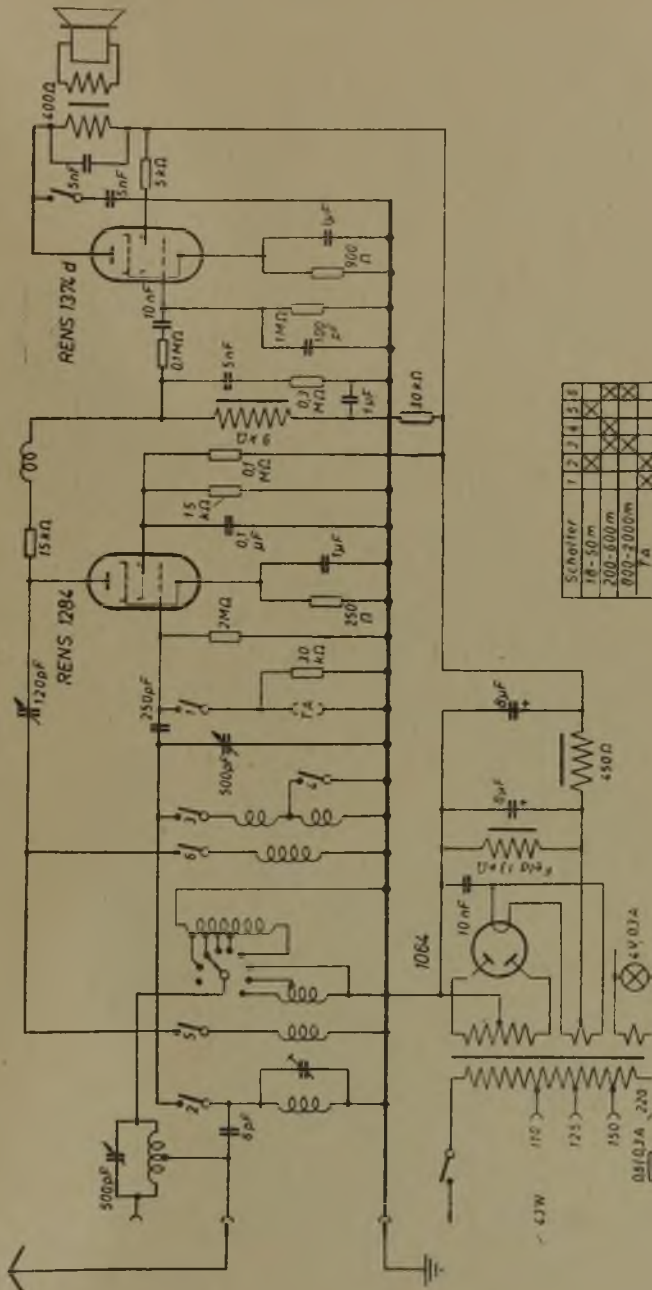

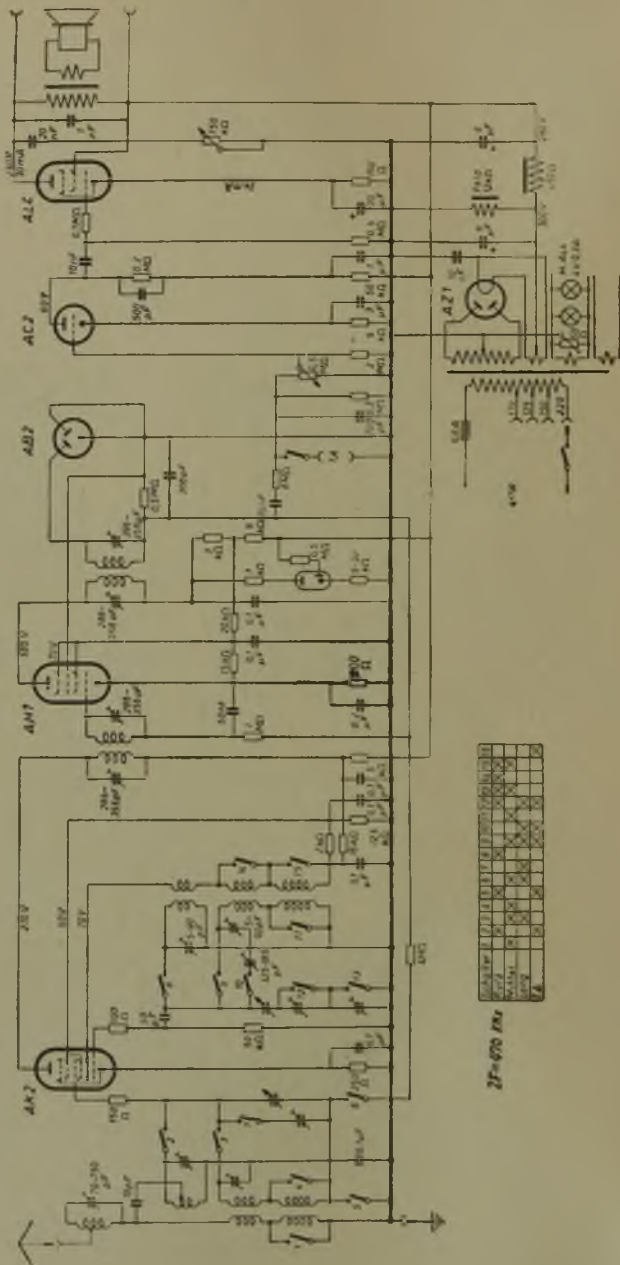

1	2	3	4	5	6	7	8	9	10	11	12	13	14	15	16	17	18	19	20	21	22	23	24	25	26	27	28	29	30	31	32	33	34	35	36	37	38	39	40	41	42	43	44	45	46	47	48	49	50	51	52	53	54	55	56	57	58	59	60	61	62	63	64	65	66	67	68	69	70	71	72	73	74	75	76	77	78	79	80	81	82	83	84	85	86	87	88	89	90	91	92	93	94	95	96	97	98	99	100
---	---	---	---	---	---	---	---	---	----	----	----	----	----	----	----	----	----	----	----	----	----	----	----	----	----	----	----	----	----	----	----	----	----	----	----	----	----	----	----	----	----	----	----	----	----	----	----	----	----	----	----	----	----	----	----	----	----	----	----	----	----	----	----	----	----	----	----	----	----	----	----	----	----	----	----	----	----	----	----	----	----	----	----	----	----	----	----	----	----	----	----	----	----	----	----	----	----	----	-----

2P-470 204

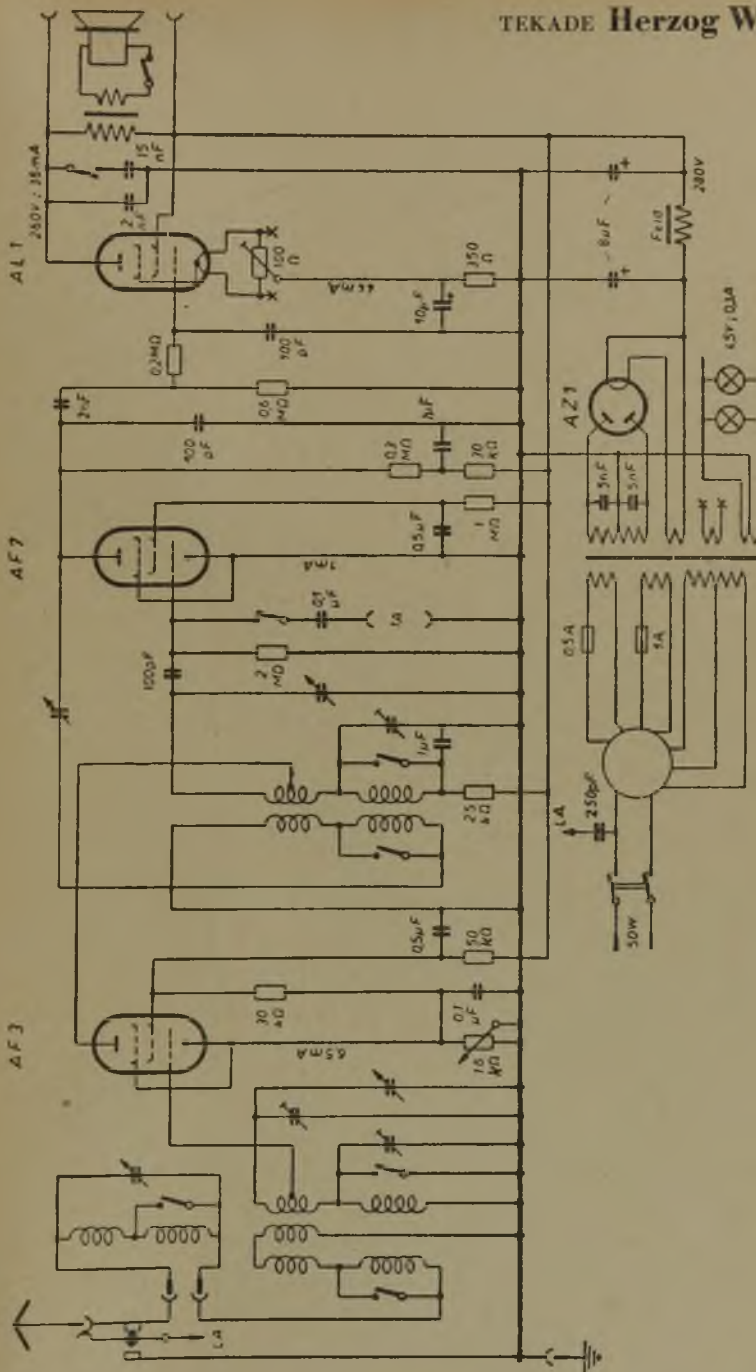

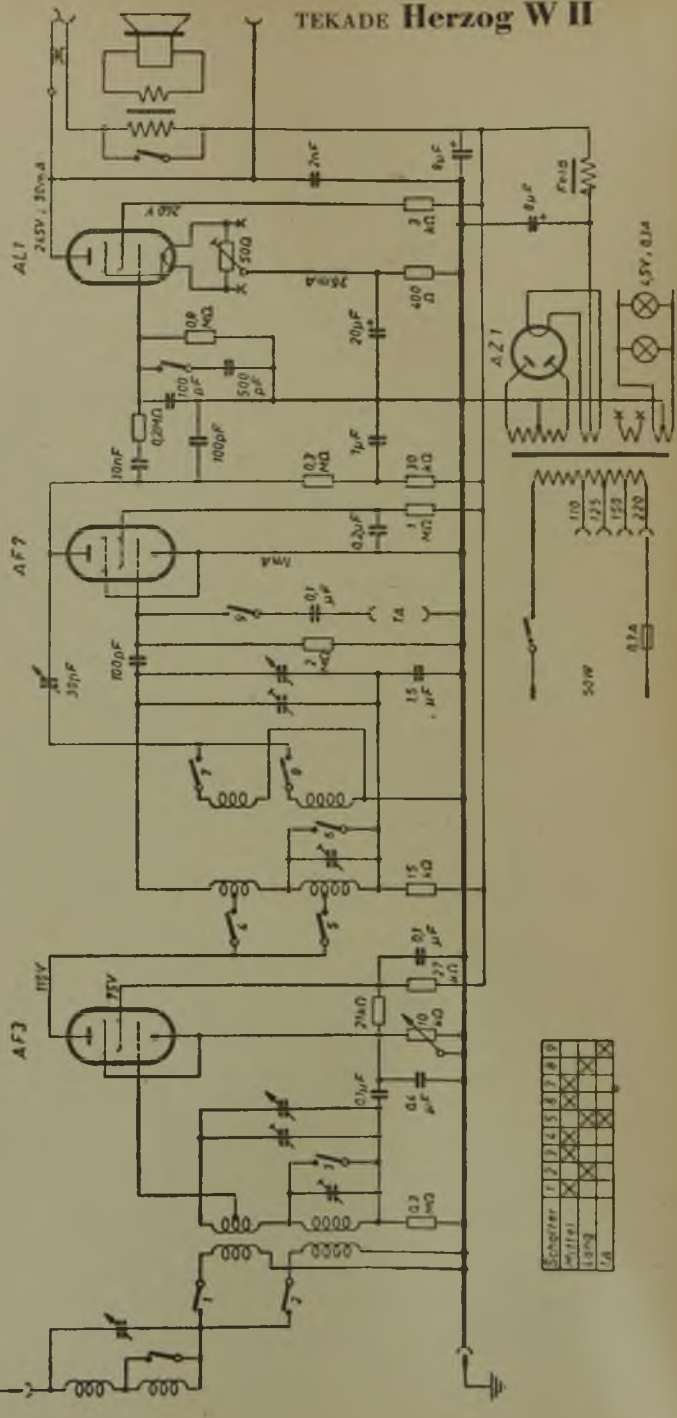

Schalter	1	2	3	4	5	6	7	8	9
Mittel									
Lang									
FA									

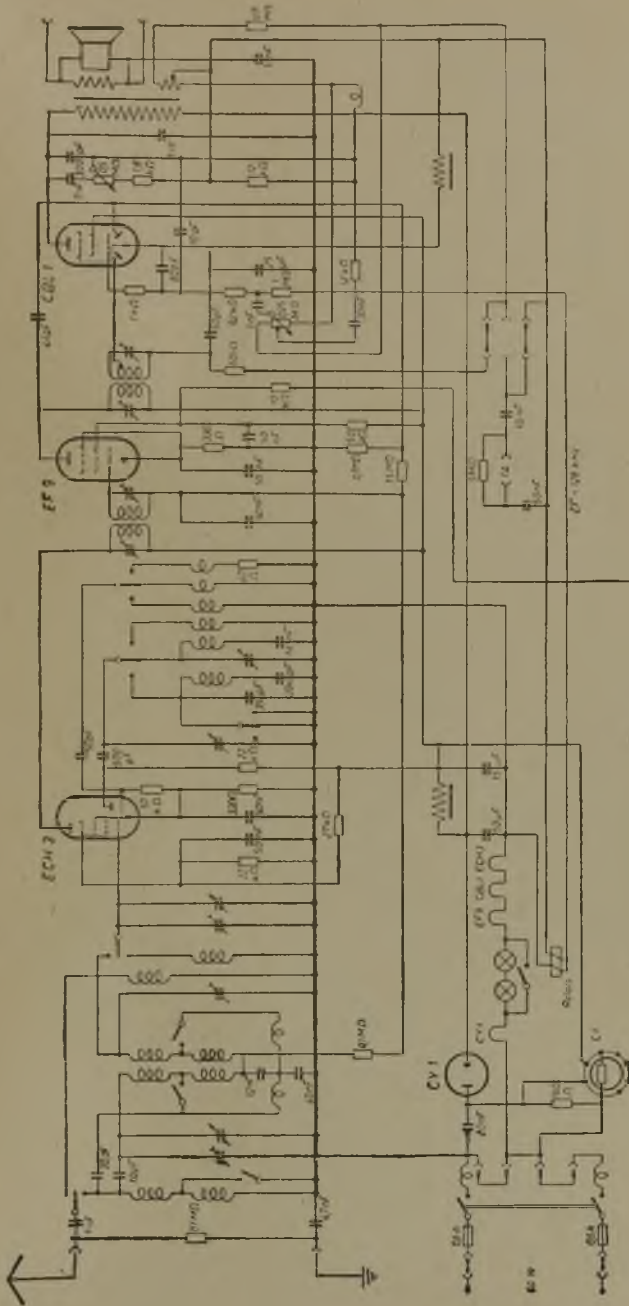

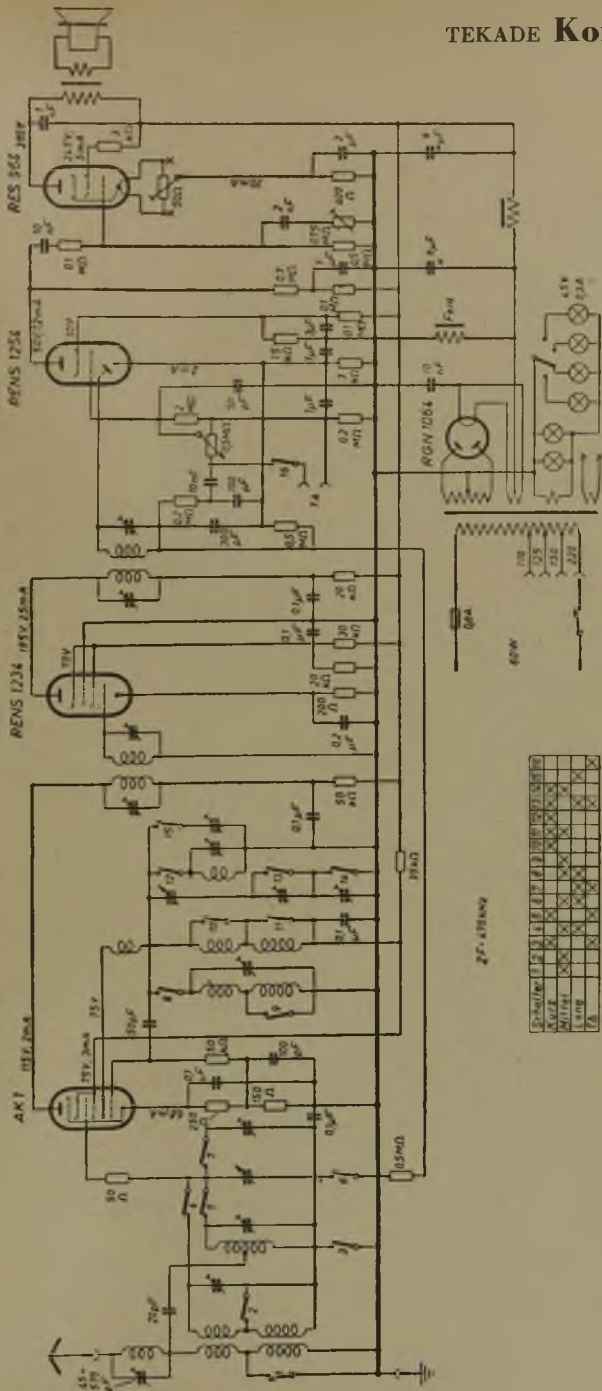

1	2	3	4	5	6	7	8	9	10	11	12	13	14	15	16	17	18	19	20	21	22	23	24	25	26	27	28	29	30	31	32	33	34	35	36	37	38	39	40	41	42	43	44	45	46	47	48	49	50	51	52	53	54	55	56	57	58	59	60	61	62	63	64	65	66	67	68	69	70	71	72	73	74	75	76	77	78	79	80	81	82	83	84	85	86	87	88	89	90	91	92	93	94	95	96	97	98	99	100
---	---	---	---	---	---	---	---	---	----	----	----	----	----	----	----	----	----	----	----	----	----	----	----	----	----	----	----	----	----	----	----	----	----	----	----	----	----	----	----	----	----	----	----	----	----	----	----	----	----	----	----	----	----	----	----	----	----	----	----	----	----	----	----	----	----	----	----	----	----	----	----	----	----	----	----	----	----	----	----	----	----	----	----	----	----	----	----	----	----	----	----	----	----	----	----	----	----	----	-----

TEKADE LES 43 KML

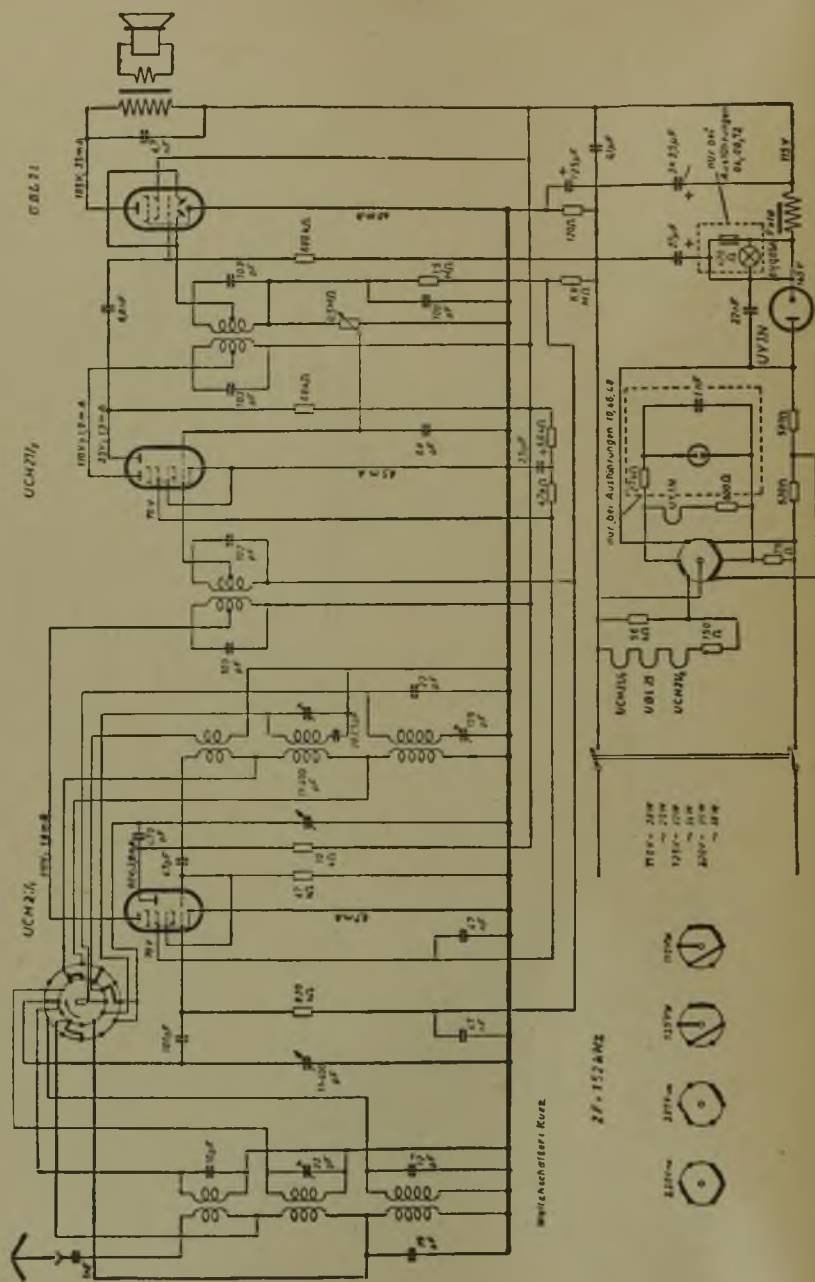

UCM214
100V, 10W
250V, 10W

UCM215
100V, 10W
250V, 10W

UCM216
110V, 110W
220V, 110W

UCM217
100V, 10W
250V, 10W

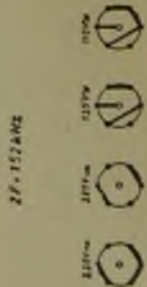

ZF = 152 kHz

Witchschalter: Kurz

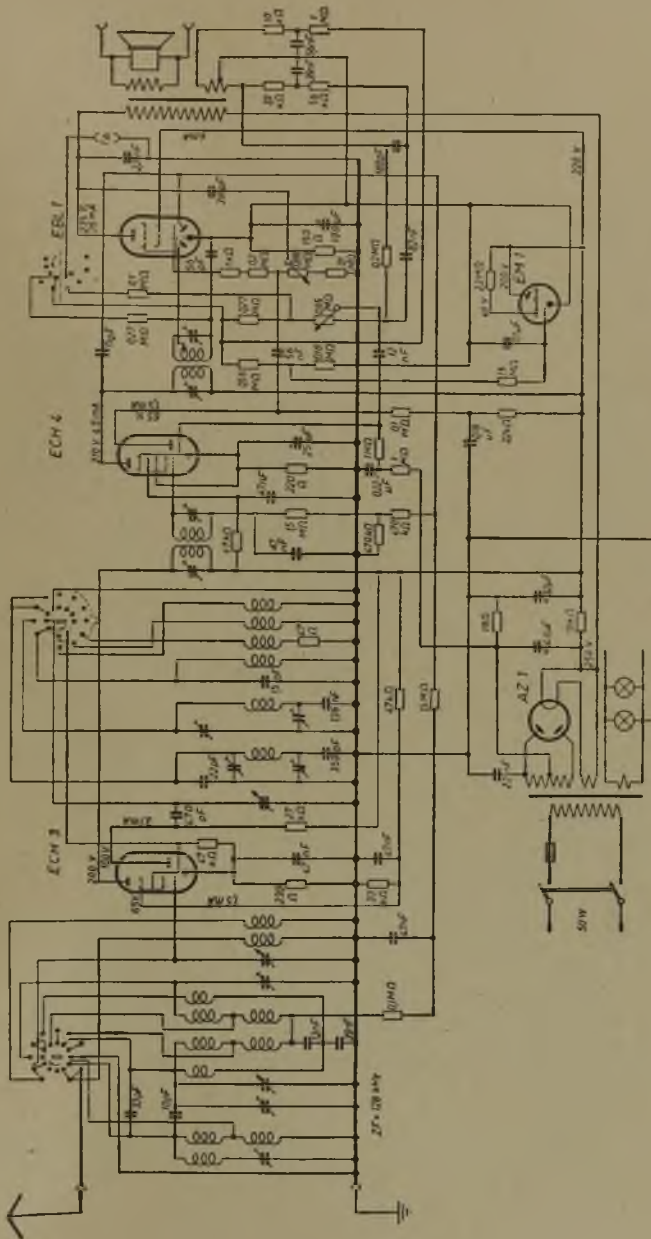

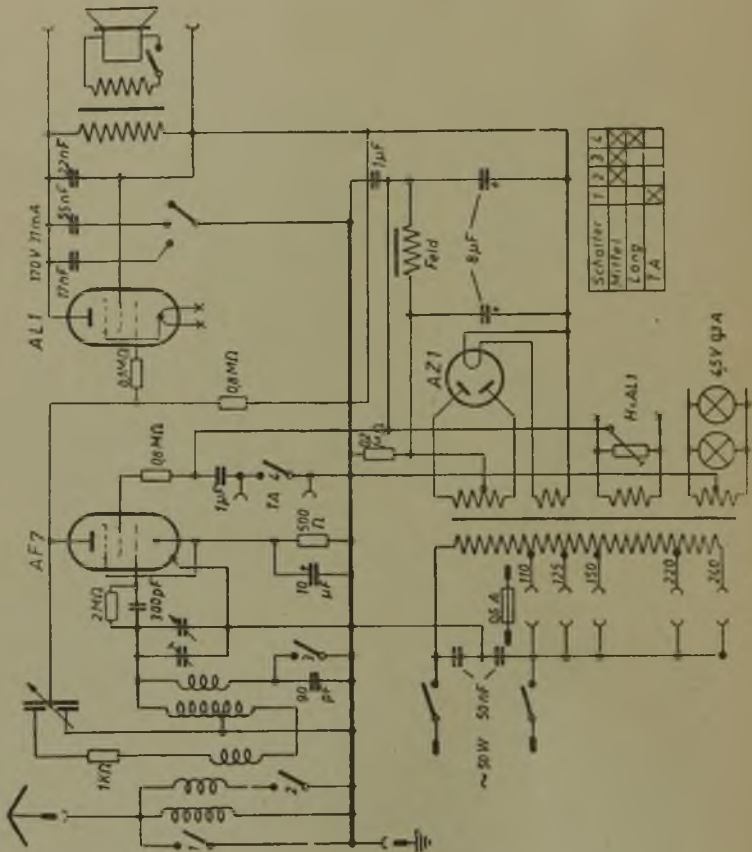

Schalter	1	2	3	4
Writter	×	×	×	×
Long	×	×	×	×
T.A.	×	×	×	×

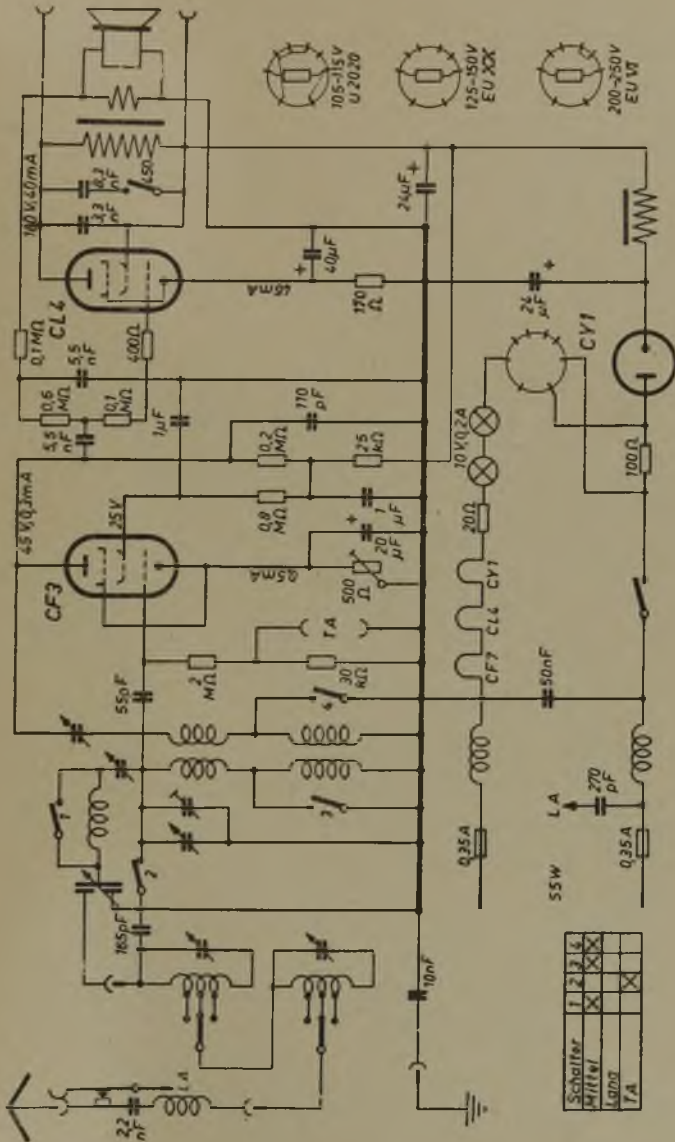

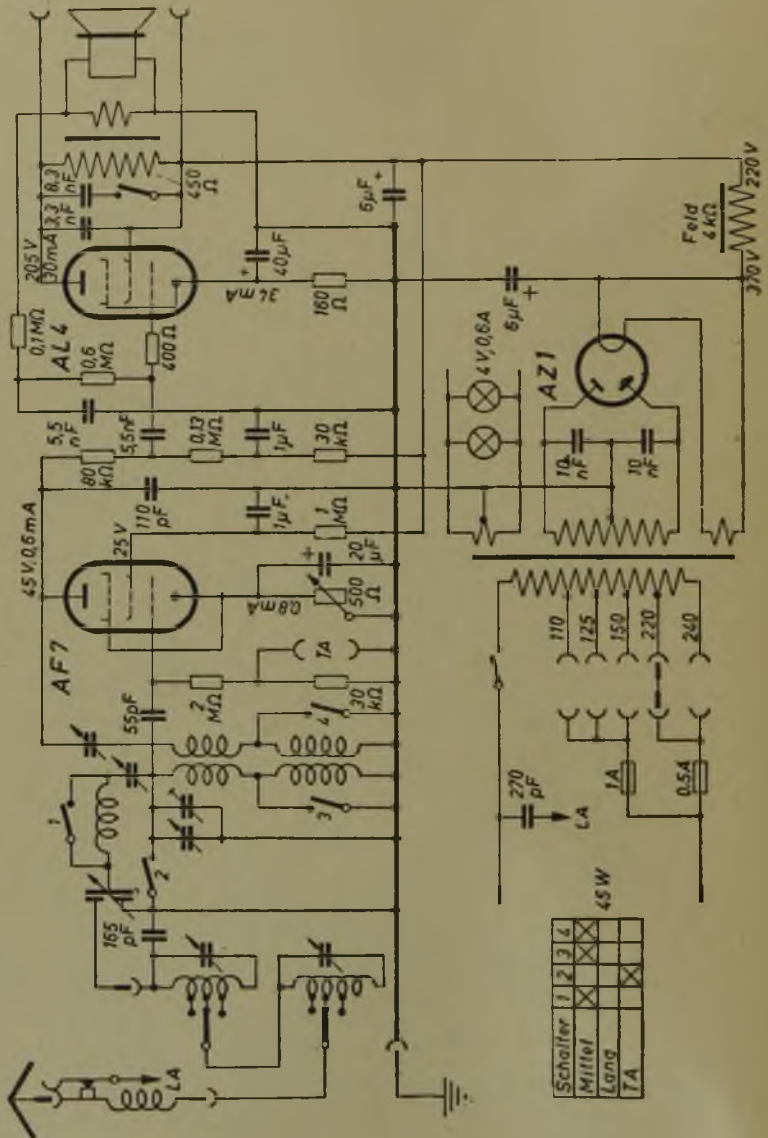

Folgende Hersteller sind in der Schaltbildersammlung enthalten:

AEG	Klangfilm	VEB Funkwerk
Äola	Körting	Zittau-Oberdorf
Akkord	Kreff	VEB Stern Radio Berlin
Atlas	Lange	VEB Stern-Radio Leipzig
Blaupunkt	Lembeck	VEB Stern-Radio Rochlitz
Blohm	Loewe/Opta	VRB Stern-Radio Staffurt
Brandt	Lorenz	RFW
Braun	LTP	Riweco
Continental	Lumophon	Rohde u. Schwarz
DTW	Mende	Rnwel
Elbeg	Meßgerätebau	Saba
Elbia	Metz	Sachsenwerk
Elcophon	MEW	Schalero
Elektro-Apparate-Fabrik Köppelsdorf	Niemann	Schaub
Elektro-Apparate-Werke Treprow	Nora	Seibt
Elmug	Nord-Mende	* Siemens
Eltra	Opta-Spezial	* Star
Emud	Owin	* Staffurt
Funkstrahl	Pellegrinetti	* Staudigl
Gemeinschafts-Empfänger	Philips	* Südfunk
Geta	Radio-Union	* TAK
Graetz	Reico	* Tefag
Graßmann	Rema	* Tefi
Grundig		* TEKADE
Haco		Telefunken
Hagenuk		Tonfunk
Huth		Waldschmidt
Jotba		Wandel und Goltermann
Jungmann		Wega
		Willisen
		Wobbe

RFT:

Firmen in Österreich:

Eumig	Kapsch	Radione
Hornophon	Krischker	Zebetner
Ingelen	Minerva	Zerdik

*Die mit einem * versehenen Firmen sind in diesem Band enthalten*

FACHBUCHVERLAG LEIPZIG

Im gleichen Verlag erscheinen:

Kurzwellenantennen

Theorie, Berechnung und Konstruktion

Von G. S. Ajsenberg

Übersetzung aus dem Russischen

514 Seiten mit 524 Bildern · DIN C 5 · Kunstleder 28,— DM

Dieses Fachbuch behandelt alle Probleme, die beim Entwurf und bei der praktischen Ausführung von Kurzwellenantennen auftreten, in einer so zusammenfassenden Darstellung, wie sie bisher in der deutschen technischen Literatur noch nicht veröffentlicht worden ist. Der Verfasser bietet sowohl dem Theoretiker als auch dem Praktiker genügend Unterlagen, daß beide das Werk mit Erfolg benutzen können. Die vielen beigegebenen Richtcharakteristiken der verschiedensten Antennen erleichtern die Auswahl und vereinfachen die Berechnung.

Einführung in die Kurzwellen- und Ultrakurzwellen- Empfänger-Praxis

Von Obering. Karl-August Springstein, Verdienter Erfinder

3. Auflage

456 Seiten mit 429 Bildern und zahlreichen Tabellen und Tafeln
DIN C 5 · Hlw. 13,50 DM

Das Fachbuch leitet zum Bau und Gebrauch der Kurzwellen- und Ultrakurzwellenempfänger an. Es behandelt zunächst ihre Aufgaben und die verschiedenen Arten der Signale und geht dann näher auf die Konstruktion und die Handhabung der einzelnen Empfängerarten ein. Dabei hat der Verfasser immer die Gegebenheiten der Praxis im Auge und verzichtet im allgemeinen auf theoretisch tiefergehendes Begründen durch längere mathematische Ableitungen. Nur dort, wo es ihm für das Verständnis der technischen Zusammenhänge notwendig erschien, wurden einige solche Ableitungen gegeben. Sie stellen jedoch keine besonderen mathematischen Anforderungen an den Leser. Das Buch setzt die Kenntnisse der Grundlagen des Mittel- und Langwellenempfanges sowie der umfangreichen Probleme der Niederfrequenztechnik als bekannt voraus.

Zu beziehen durch jede Buchhandlung

FACHBUCHVERLAG LEIPZIG

Sowjetische Fachbücher in deutscher Übersetzung:

Rundfunktechnik

mit einem Anhang: Kristalldioden und Transistoren

Von I. P. Shereb zow

2., verbesserte und erweiterte Auflage

426 Seiten mit 283 Bildern · DIN C 5 · Hlw. 10,80 DM

Nach einer kurzen Übersicht über die technische Entwicklung und die neuesten Erfahrungen auf dem Gebiet der Funktechnik und über die hervorragenden Arbeiten sowjetischer Gelehrter auf diesem Gebiet behandelt das Buch die Grundlagen der neuzeitlichen Funktechnik und die physikalischen Vorgänge in Funkanlagen. Bemerkenswert sind die Erweiterungen der zweiten Auflage: eine Vergleichstabelle über sowjetische und deutsche Röhren, ein umfangreiches Verzeichnis einschlägiger deutscher Fachliteratur und der Anhang, in dem erstmalig in der Deutschen Demokratischen Republik eine zusammenfassende Darstellung über Kristalldioden und Transistoren gegeben wird.

Aus dem Reiche der Radiowellen

Von F. Tschestnow

220 Seiten mit 88 Bildern · DIN B 6 · Kunstleder 2,85 DM

Das Buch bringt eine allgemeinverständliche Einführung in das Wesen der hochfrequenten Ströme und ihre vielseitige Anwendung bei der drahtlosen Übertragung von Sprache und Bild, im Sicherungswesen von Schiffs- und Flugverkehr, bei der Echolotung für Tiefen- und Höhenmessung, in der Medizin, in der Metallurgie usw. Wissenschaftlich exakt, reich bebildert und gut gegliedert, bildet das Werk somit eine sichere Grundlage für jedermann, der bestrebt ist, sich mit diesem interessanten Gebiet vertraut zu machen.

Zu beziehen durch jede Buchhandlung

FACHBUCHVERLAG LEIPZIG

Sowjetische Fachbücher in deutscher Übersetzung:

Gleichrichter und Spannungsregler

Von K. B. M a s e l

100 Seiten mit 55 Bildern · DIN C 5 · Hlw. 5,— DM

Für das einwandfreie Arbeiten eines Funkgerätes ist seine Stromversorgung von ausschlaggebender Bedeutung. Geräte und Schaltungen, die den Strom gleichrichten und die Spannung stabilisieren, gehören daher zu den Baugruppen eines Funkgerätes, deren Berechnung und Konstruktion mit besonderer Sorgfalt und Exaktheit ausgeführt werden müssen.

Das Fachbuch enthält alles Wissenswerte über dieses Spezialgebiet und wird in seiner Vielseitigkeit und seiner präzisen, durch zahlreiche Bilder unterstützten Darstellung dem deutschen Fachmann ein wertvolles Hilfsmittel sein.

Phasenwinkelmodulation

Von Dipl.-Ing. Alexander R a s c h k o w i t s c h

183 Seiten mit 121 Bildern · DIN C 5 · Hlw. 7.50 DM

Nach einem Überblick über die technischen und wirtschaftlichen Grundlagen der Funktechnik wird in diesem Buch ausführlich das theoretische Grundwissen behandelt. Der Verfasser leitet sodann die kennzeichnenden Eigenschaften der Phasenwinkelmodulation ab und erläutert sie; dabei setzt er mathematische Kenntnisse voraus. Allgemein verständlich werden Einzelheiten, wie Oszillatoren, Modulatoren, Vervielfacher und Verstärker der Sendeanlagen und die typischen Eigenheiten der Empfänger, insbesondere die verschiedenen Modulationsschaltungen, beschrieben. Das Buch entspricht dem neuesten Stand der Wissenschaft und Technik. Zahlreiche Beispiele und praktische Ableitungen, Diagramme und Schaltskizzen erhöhen den Wert der Ausführungen für die Praxis.

Zu beziehen durch jede Buchhandlung

FACHBUCHVERLAG LEIPZIG

BG Politechniki Śląskiej

nr inw.: 102 - 126438



Dyr.1 126438